

YG-1 TOOLING SYSTEM

SHRINK FIT HOLDER

- SCHRUMPFUTTER
- MANDRIN DE FRETTAGE
- MADRINI PER CALLETAMENTO A CALDO
- PORTAHERRAMIENTAS DE COMPRESION POR CALOR



DIN 69871-SK

DIN 69893/ISO 12164-1-HSK

CBT (BT DUAL CONTACT)

JIS B6339/MAS 403-BT

ISO 25

SHRINK FIT HEATING MACHINE

TECHNICAL INFORMATION

SHRINK FIT HOLDER



High Precision I.D

Run-out : $\leq 0.003\text{mm}$

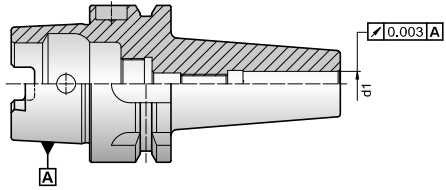

- Less than 0.003mm of Tool Holder accuracy at I.D

Strong and Consistent Torque Power

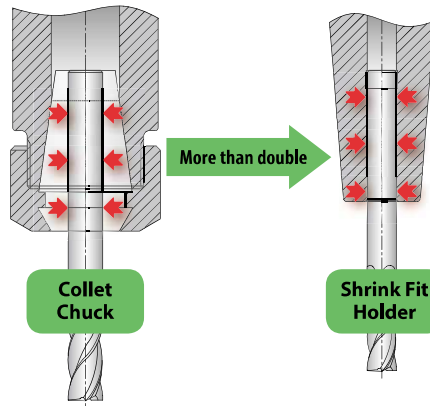

- Achieving strong torque power by integration of chuck and tool

Deep hole Machining

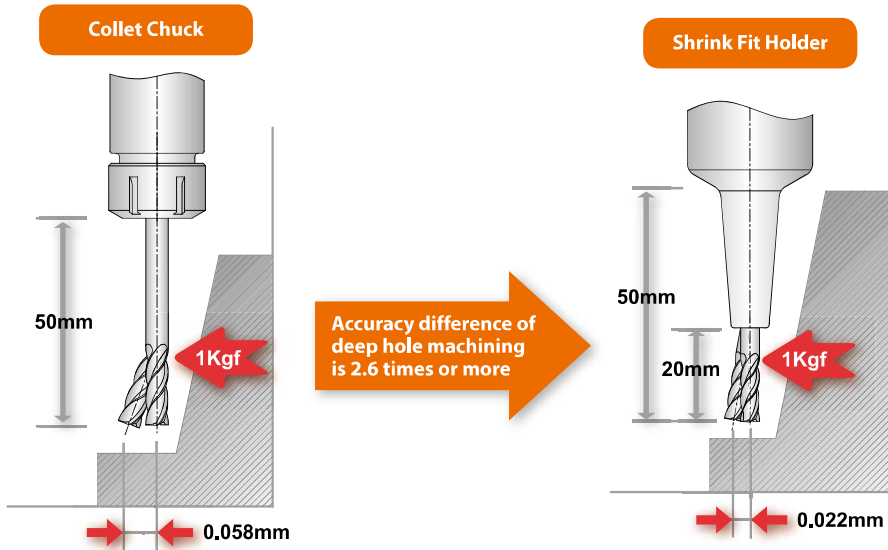

- Suitable for High-Speed precision deep hole machining

TECHNICAL INFORMATION

SHRINK FIT HOLDER



APPLICATION

Rough Milling	Finish Milling	High-Speed Cutting
Drilling	Reaming	Countersinking

Shank Type of Cutting Tool

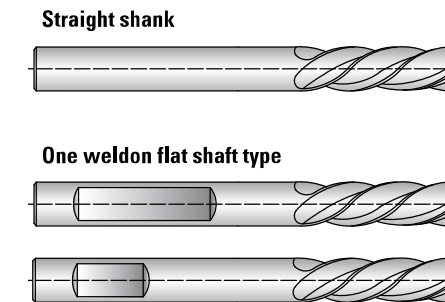

Material of Cutting Tool

CARBIDE TOOL	HSS TOOL
	NO
OK	

- One Weldon flat shaft type tool is usable, but there is a possibility that the I.D of shrink fit holder may be deformed.

SHRINK FIT HOLDER

SHRINK FIT HOLDER (EXTRA SLIM) **NEW**

SFHS

SCHRUMPFUTTER
MANDRIN DE FRETAGE
MADRINI PER CALLETAMENTO A CALDO
PORTAHERRAMIENTAS DE COMPRESION POR CALOR

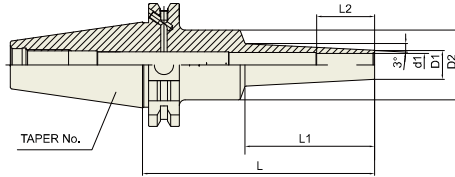

DIN 69871 -SK	Taper Accuracy AT3	G Value 2.5	RPM 25,000	Run-Out (I.D) ≤3Um	Coolant System AD or AD/B
---------------	--------------------	-------------	------------	--------------------	---------------------------

■ DIN 69871-SK

Unit : mm

TAPER No.	MODEL No.	EDP No.	d1	D1	D2	L	L1	L2	WEIGHT (Kg)
30	SK30-SFHS3-60	P2771332S	3	6	20	60	22	9	
	SK30-SFHS3-80	P2771333S	3	6	20	80	42	9	
	SK30-SFHS4-60	P2771334S	4	7	20	60	22	12	
	SK30-SFHS4-80	P2771335S	4	7	20	80	42	12	
	SK30-SFHS6-60	P2771336S	6	9	20	60	22	18	
	SK30-SFHS6-80	P2771337S	6	9	20	80	42	18	
40	SK40AD/B-SFHS3-95	P2771338S	3	6	26	95	42	9	
	SK40AD/B-SFHS3-120	P2771339S	3	6	26	120	67	9	
	SK40AD/B-SFHS4-95	P2771340S	4	7	26	95	42	12	
	SK40AD/B-SFHS4-120	P2771341S	4	7	26	120	67	12	
	SK40AD/B-SFHS6-95	P2771342S	6	9	26	95	42	18	
	SK40AD/B-SFHS6-120	P2771343S	6	9	26	120	67	18	
	SK40AD/B-SFHS8-95	P2771344S	8	11	36	95	42	24	
	SK40AD/B-SFHS8-120	P2771345S	8	11	36	120	67	24	
	SK40AD/B-SFHS10-95	P2771346S	10	13	36	95	42	30	
	SK40AD/B-SFHS10-120	P2771347S	10	13	36	120	67	30	
	SK40AD/B-SFHS12-95	P2771348S	12	15	36	95	42	30	
	SK40AD/B-SFHS12-120	P2771349S	12	15	36	120	67	30	
50	SK50AD/B-SFHS3-110	P2771350S	3	6	26	110	42	9	
	SK50AD/B-SFHS3-160	P2771351S	3	6	26	160	97	9	
	SK50AD/B-SFHS4-110	P2771352S	4	7	26	110	42	12	
	SK50AD/B-SFHS4-160	P2771353S	4	7	26	160	97	12	
	SK50AD/B-SFHS6-110	P2771354S	6	9	26	110	42	18	
	SK50AD/B-SFHS6-160	P2771355S	6	9	26	160	97	18	
	SK50AD/B-SFHS8-110	P2771356S	8	11	36	110	42	24	
	SK50AD/B-SFHS8-160	P2771357S	8	11	36	160	97	24	
	SK50AD/B-SFHS10-110	P2771358S	10	13	36	110	42	30	
	SK50AD/B-SFHS10-160	P2771359S	10	13	36	160	97	30	
	SK50AD/B-SFHS12-110	P2771360S	12	15	36	110	42	30	
	SK50AD/B-SFHS12-160	P2771361S	12	15	36	160	97	30	

► CAT(ANSI B5.50) taper and Inch type products are available.

SHRINK FIT HOLDER

SHRINK FIT HOLDER

SFH

SCHRUMPFUTTER
MANDRIN DE FRETAGE
MADRINI PER CALLETAMENTO A CALDO
PORTAHERRAMIENTAS DE COMPRESION POR CALOR

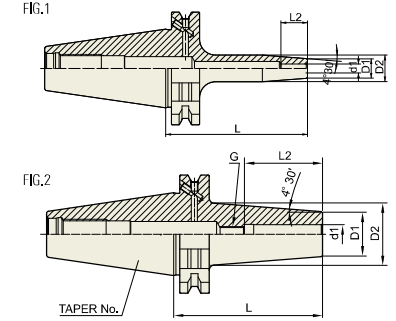

DIN 69871 -SK	Taper Accuracy AT3	G Value 2.5	RPM 25,000	Run-Out (I.D) ≤3Um	Coolant System AD or AD/B
---------------	--------------------	-------------	------------	--------------------	---------------------------

■ DIN 69871-SK

Unit : mm

TAPER No.	MODEL No.	EDP No.	d1	D1	D2	L	L2	G	FIG.	WEIGHT (Kg)
30	SK30-SFH3-60	P2771308A	3	11	15	60	10	-	1	0.40
	SK30-SFH4-60	P2771309A	4	11	15	60	12	-	1	0.40
	SK30-SFH5-60	P2771310A	5	11	15	60	15	-	1	0.40
	SK30-SFH6-60	P2771311A	6	21	27	60	36	M5x0.8	2	0.40
	SK30-SFH8-60	P2771312A	8	21	27	60	36	M6x1.0	2	0.40
	SK30-SFH10-80	P2771313A	10	24	32	80	42	M8x1.0	2	0.40
	SK30-SFH12-80	P2771314A	12	24	32	80	47	M10x1.0	2	0.42
	SK30-SFH14-80	P2771315A	14	27	34	80	47	M10x1.0	2	
	SK30-SFH16-80	P2771316A	16	27	34	80	50	M12x1.0	2	0.42
	SK30-SFH18-80	P2771317A	18	33	42	80	50	M12x1.0	2	
	SK30-SFH20-90	P2771318A	20	33	42	90	52	M16x1.0	2	0.44
	40	SK40AD/B-SFH3-80	P27713101	3	11	15	80	10	-	1
SK40AD/B-SFH4-80		P27713102	4	11	15	80	12	-	1	1.00
SK40AD/B-SFH5-80		P27713103	5	11	15	80	15	-	1	1.00
SK40AD/B-SFH6-80		P2554058	6	21	27	80	36	M5x0.8	2	1.10
SK40AD/B-SFH6-160		P27713104	6	21	27	160	36	M5x0.8	2	1.15
SK40AD/B-SFH8-80		P2600009	8	21	27	80	36	M6x1.0	2	1.11
SK40AD/B-SFH8-160		P27713105	8	21	27	160	36	M6x1.0	2	1.15
SK40AD/B-SFH10-80		P2554052	10	24	32	80	42	M8x1.0	2	1.10
SK40AD/B-SFH10-160		P27713106	10	24	32	160	42	M8x1.0	2	1.15
SK40AD/B-SFH12-80		P2600008	12	24	32	80	47	M10x1.0	2	1.10
SK40AD/B-SFH12-160		P27713107	12	24	32	160	47	M10x1.0	2	1.15
SK40AD/B-SFH14-80		P27713119	14	27	34	80	47	M10x1.0	2	1.20
SK40AD/B-SFH14-160		P27713120	14	27	34	160	47	M10x1.0	2	1.50
SK40AD/B-SFH16-80		P2554054	16	27	34	80	50	M12x1.0	2	1.20
SK40AD/B-SFH16-160		P2554053	16	27	34	160	50	M12x1.0	2	1.50
SK40AD/B-SFH18-80		P27713121	18	33	42	80	50	M12x1.0	2	1.30
SK40AD/B-SFH18-160		P27713122	18	33	42	160	50	M12x1.0	2	1.60
SK40AD/B-SFH20-80		P2554056	20	33	42	80	52	M16x1.0	2	1.40
SK40AD/B-SFH20-160		P2554055	20	33	42	160	52	M16x1.0	2	1.70
SK40AD/B-SFH25-90		P27713123	25	44	53	90	58	M16x1.0	2	1.70
SK40AD/B-SFH25-160	P27713124	25	44	53	160	58	M16x1.0	2	2.00	

► CAT(ANSI B5.50) taper and Inch type products are available.
► Without balancing screw.

SHRINK FIT HOLDER

SCHRUMPFUTTER
MANDRIN DE FRETAGE
MADRINI PER CALLETAMENTO A CALDO
PORTAHERRAMIENTAS DE COMPRESION POR CALOR



DIN 69871-SK

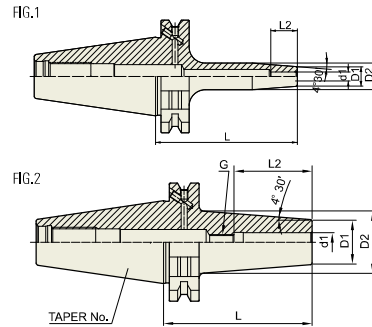

DIN 69871-SK	Taper Accuracy AT3	G Value 2.5	RPM 25,000	Run-Out (I.D) ≤3Um	Coolant System AD/B
--------------	--------------------	-------------	------------	--------------------	---------------------

Unit : mm										
TAPER No.	MODEL No.	EDP No.	d1	D1	D2	L	L2	G	FIG.	WEIGHT (Kg)
50	SK50AD/B-SFH3-80	P2771325	3	11	15	100	10	-	1	1.50
	SK50AD/B-SFH4-80	P2771326	4	11	15	100	12	-	1	1.50
	SK50AD/B-SFH5-80	P2771327	5	11	15	100	15	-	1	1.50
	SK50AD/B-SFH6-80	P2771328	6	21	27	80	36	M5x0.8	2	1.50
	SK50AD/B-SFH6-160	P2771329	6	21	27	160	36	M5x0.8	2	2.00
	SK50AD/B-SFH8-80	P2760010	8	21	27	80	36	M6x1.0	2	1.50
	SK50AD/B-SFH8-160	P2760015	8	21	27	160	36	M6x1.0	2	2.00
	SK50AD/B-SFH10-80	P2761010	10	24	32	80	42	M8x1.0	2	1.50
	SK50AD/B-SFH10-160	P2761015	10	24	32	160	42	M8x1.0	2	2.00
	SK50AD/B-SFH12-80	P2762010	12	24	32	80	47	M10x1.0	2	1.50
	SK50AD/B-SFH12-160	P2762015	12	24	32	160	47	M10x1.0	2	2.00
	SK50AD/B-SFH14-80	P2763010	14	27	34	80	47	M10x1.0	2	1.60
SK50AD/B-SFH14-160	P2763015	14	27	34	160	47	M10x1.0	2	2.10	
SK50AD/B-SFH16-80	P2764010	16	27	34	80	50	M12x1.0	2	1.60	
SK50AD/B-SFH16-160	P2764015	16	27	34	160	50	M12x1.0	2	2.10	
SK50AD/B-SFH18-80	P2765010	18	33	42	80	50	M12x1.0	2	1.60	
SK50AD/B-SFH18-160	P2765015	18	33	42	160	50	M12x1.0	2	2.00	
SK50AD/B-SFH20-80	P2766010	20	33	42	80	52	M16x1.0	2	1.80	
SK50AD/B-SFH20-160	P2766015	20	33	42	160	52	M16x1.0	2	2.20	
SK50AD/B-SFH25-90	P2771330	25	44	53	90	58	M16x1.0	2	2.00	
SK50AD/B-SFH25-160	P2771331	25	44	53	160	58	M16x1.0	2	2.40	

▶ CAT(ANSI B5.50) taper and Inch type products are available.
▶ Without balancing screw.

SHRINK FIT HOLDER (EXTRA SLIM) NEW

SCHRUMPFUTTER
MANDRIN DE FRETAGE
MADRINI PER CALLETAMENTO A CALDO
PORTAHERRAMIENTAS DE COMPRESION POR CALOR

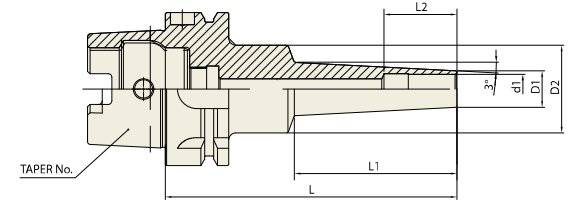

DIN 69893-HSK	Taper Accuracy AT3	G Value 2.5	RPM 25,000	Run-Out (I.D) ≤3Um	Coolant System AD
---------------	--------------------	-------------	------------	--------------------	-------------------

DIN 69893/ISO 12164-1-HSK FORM A

Unit : mm										
TAPER No.	MODEL No.	EDP No.	d1	D1	D2	L	L1	L2	WEIGHT (Kg)	
40A	HSK40A-SFH3-60	P27798015	3	6	20	60	22	9		
	HSK40A-SFH3-90	P27798025	3	6	20	80	22	9		
	HSK40A-SFH4-60	P27798035	4	7	20	60	22	12		
	HSK40A-SFH4-90	P27798045	4	7	20	80	22	12		
	HSK40A-SFH5-60	P27798055	6	9	20	60	22	18		
	HSK40A-SFH5-90	P27798065	6	9	20	80	22	18		
	HSK50A-SFH3-95	P27798075	3	6	26	95	42	9		
	HSK50A-SFH3-120	P27798085	3	6	26	120	42	9		
	HSK50A-SFH4-95	P27798095	4	7	26	95	42	12		
	HSK50A-SFH4-120	P27798105	4	7	26	120	42	12		
	HSK50A-SFH5-95	P27798115	6	9	26	95	42	18		
	HSK50A-SFH5-120	P27798125	6	9	26	120	42	18		
50A	HSK50A-SFH5-95	P27798135	8	11	36	95	42	24		
	HSK50A-SFH5-120	P27798145	8	11	36	120	42	24		
	HSK50A-SFH10-95	P27798155	10	13	36	95	42	30		
	HSK50A-SFH10-120	P27798165	10	13	36	120	42	30		
	63A	HSK63A-SFH3-95	P27798175	3	6	26	95	42	9	
		HSK63A-SFH3-120	P27798185	3	6	26	120	42	9	
		HSK63A-SFH4-95	P27798195	4	7	26	95	42	12	
		HSK63A-SFH4-120	P27798205	4	7	26	120	42	12	
		HSK63A-SFH5-95	P27798215	6	9	26	95	42	18	
		HSK63A-SFH5-120	P27798225	6	9	26	120	42	18	
		HSK63A-SFH5-95	P27798235	8	11	36	95	42	24	
		HSK63A-SFH5-120	P27798245	8	11	36	120	42	24	
HSK63A-SFH10-95		P27798255	10	13	36	95	42	30		
HSK63A-SFH10-160		P27798265	10	13	36	160	42	30		
HSK63A-SFH12-95		P27798275	12	15	36	95	42	30		
HSK63A-SFH12-160		P27798285	12	15	36	160	42	30		
100A	HSK100A-SFH3-95	P27798295	3	6	26	95	42	9		
	HSK100A-SFH3-120	P27798305	3	6	26	120	42	9		
	HSK100A-SFH4-95	P27798315	4	7	26	95	42	12		
	HSK100A-SFH4-120	P27798325	4	7	26	120	42	12		
	HSK100A-SFH5-95	P27798335	6	9	26	95	42	18		
	HSK100A-SFH5-120	P27798345	6	9	26	120	42	18		
	HSK100A-SFH5-95	P27798355	8	11	36	95	42	24		
	HSK100A-SFH5-120	P27798365	8	11	36	120	42	24		
	HSK100A-SFH10-95	P27798375	10	13	36	95	42	30		
	HSK100A-SFH10-160	P27798385	10	13	36	160	42	30		
	HSK100A-SFH12-95	P27798395	12	15	36	95	42	30		
	HSK100A-SFH12-160	P27798405	12	15	36	160	42	30		

▶ CAT(ANSI B5.50) taper and Inch type products are available.

SHRINK FIT HOLDER

SFH

SCHRUMPFUTTER
MANDRIN DE FRETAGE
MADRINI PER CALLETAMENTO A CALDO
PORTAHERRAMIENTAS DE COMPRESION POR CALOR

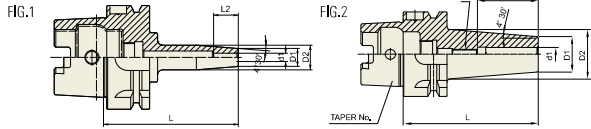

DIN 69893 - HSK	Taper Accuracy	G Value	RPM	Run-Out (I.D)	Coolant System
-	-	2.5	25,000	≤3Um	AD

DIN 69893/ISO 12164-1-HSK FORM A

TAPER No.	MODEL No.	EDP No.	d1	D1	D2	L	L2	G	FIG.	WEIGHT (Kg)
40A	HSK40A-SFH3-60	P2771408	3	11	15	60	10	-	1	0.30
	HSK40A-SFH3-80	P2771409	3	11	15	80	10	-	1	0.40
	HSK40A-SFH4-60	P2771410	4	11	15	60	12	-	1	0.30
	HSK40A-SFH4-80	P2771411	4	11	15	80	12	-	1	0.40
	HSK40A-SFH5-60	P2771412	5	11	15	60	15	-	1	0.30
	HSK40A-SFH5-80	P2771413	5	11	15	80	15	-	1	0.40
	HSK40A-SFH6-60	P2771414	6	21	27	60	36	M5x0.8	2	0.40
	HSK40A-SFH6-80	P2771415	6	21	27	80	36	M5x0.8	2	0.50
	HSK40A-SFH8-70	P2771416	8	21	27	70	36	M6x1.0	2	0.40
	HSK40A-SFH8-90	P2771417	8	21	27	90	36	M6x1.0	2	0.50
	HSK40A-SFH10-70	P2771418	10	24	32	70	42	M8x1.0	2	0.50
	HSK40A-SFH10-90	P2771419	10	24	32	90	42	M8x1.0	2	0.60

▶ Without balancing screw.

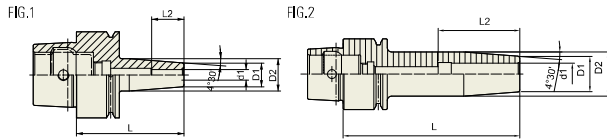

DIN 69893 - HSK	Taper Accuracy	G Value	RPM	Run-Out (I.D)	Coolant System
-	-	2.5	25,000	≤3Um	AD

DIN 69893/ISO 12164-1-HSK FORM E

TAPER No.	MODEL No.	EDP No.	d1	D1	D2	L	L2	G	FIG.	WEIGHT (Kg)
25E	HSK25E-SFH3-45	P2771420	3	11	15	45	10	-	1	0.40
	HSK25E-SFH4-45	P2771421	4	11	15	45	12	-	1	0.40
	HSK25E-SFH5-45	P2771422	5	11	15	45	15	-	1	0.40
	HSK25E-SFH6-45	P2771423	6	12	17	45	18	-	2	0.40
	HSK25E-SFH8-45	P2771424	8	14	18	45	30	-	2	0.40
	HSK25E-SFH10-50	P2771425	10	16	20	50	37	-	2	0.40
	HSK32E-SFH3-60	P2771426	3	11	15	60	10	-	1	0.40
	HSK32E-SFH4-60	P2771427	4	11	15	60	12	-	1	0.40
	HSK32E-SFH5-60	P2771428	5	11	15	60	15	-	1	0.40
	HSK32E-SFH6-70	P2771429	6	12	17	70	18	-	2	0.40
	HSK32E-SFH8-70	P2771430	8	14	18	70	30	-	2	0.40
	HSK32E-SFH10-80	P2771431	10	16	20	80	37	-	2	0.40
	HSK40E-SFH3-60	P2771432	3	11	15	60	10	-	1	0.30
	HSK40E-SFH3-80	P2771433	3	11	15	80	10	-	1	0.40
	HSK40E-SFH4-60	P2771434	4	11	15	60	12	-	1	0.30
	HSK40E-SFH4-80	P2771435	4	11	15	80	12	-	1	0.40
	HSK40E-SFH5-60	P2771436	5	11	15	60	15	-	1	0.30
	HSK40E-SFH5-80	P2771437	5	11	15	80	15	-	1	0.40
	HSK40E-SFH6-60	P2771438	6	21	27	60	36	M5x0.8	2	0.40
	HSK40E-SFH6-80	P2771439	6	21	27	80	36	M5x0.8	2	0.50
	HSK40E-SFH8-70	P2771440	8	21	27	70	36	M6x1.0	2	0.40
	HSK40E-SFH8-90	P2771441	8	21	27	90	36	M6x1.0	2	0.50
	HSK40E-SFH10-70	P2771442	10	24	32	70	42	M8x1.0	2	0.50
	HSK40E-SFH10-90	P2771443	10	24	32	90	42	M8x1.0	2	0.60

▶ Without balancing screw.

SHRINK FIT HOLDER

SFH

SCHRUMPFUTTER
MANDRIN DE FRETAGE
MADRINI PER CALLETAMENTO A CALDO
PORTAHERRAMIENTAS DE COMPRESION POR CALOR

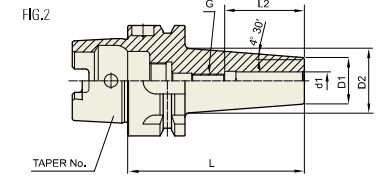
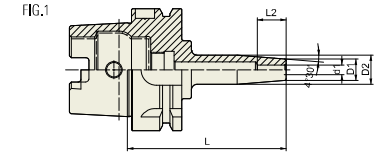

DIN 69893 - HSK	Taper Accuracy	G Value	RPM	Run-Out (I.D)	Coolant System
-	-	2.5	25,000	≤3Um	AD

DIN 69893/ISO 12164-1-HSK FORM A

TAPER No.	MODEL No.	EDP No.	d1	D1	D2	L	L2	G	FIG.	WEIGHT (Kg)
50A	HSK50A-SFH3-80	P2771444	3	11	15	80	10	-	1	0.54
	HSK50A-SFH4-80	P2771445	4	11	15	80	12	-	1	0.55
	HSK50A-SFH5-80	P2771446	5	11	15	80	15	-	1	0.56
	HSK50A-SFH6-80	P2776901	6	21	27	80	36	M5x0.8	2	0.57
	HSK50A-SFH8-80	P2771447	8	21	27	80	36	M6x1.0	2	0.58
	HSK50A-SFH10-85	P2771448	10	24	32	85	42	M8x1.0	2	0.65
	HSK50A-SFH12-90	P2771449	12	24	32	90	47	M10x1.0	2	0.67
	HSK50A-SFH14-90	P2771450	14	27	34	90	47	M10x1.0	2	0.72
	HSK50A-SFH16-95	P2771451	16	27	34	95	50	M12x1.0	2	0.73
	HSK50A-SFH18-95	P2771452	18	33	42	95	50	M12x1.0	2	0.90
	HSK50A-SFH20-100	P2771453	20	33	42	100	52	M16x1.0	2	0.92
	HSK63A-SFH3-80	P2771401	3	11	15	80	10	-	1	0.70
	HSK63A-SFH4-80	P2771402	4	11	15	80	12	-	1	0.70
	HSK63A-SFH5-80	P2771403	5	11	15	80	15	-	1	0.70
	HSK63A-SFH6-80	P2565057	6	21	27	80	36	M5x0.8	2	0.83
	HSK63A-SFH6-160	P2771404	6	21	27	160	36	M5x0.8	2	1.00
	HSK63A-SFH8-80	P2600007	8	21	27	80	36	M6x1.0	2	0.83
	HSK63A-SFH8-160	P2771405	8	21	27	160	36	M6x1.0	2	1.00
	HSK63A-SFH10-85	P2565052	10	24	32	85	42	M8x1.0	2	0.83
	HSK63A-SFH10-160	P2771406	10	24	32	160	42	M8x1.0	2	1.00
	HSK63A-SFH12-90	P2600003	12	24	32	90	47	M10x1.0	2	0.83
	HSK63A-SFH12-160	P2771407	12	24	32	160	47	M10x1.0	2	1.00
	HSK63A-SFH14-90	P2771454	14	27	34	90	47	M10x1.0	2	0.91
	HSK63A-SFH14-160	P2771455	14	27	34	160	47	M10x1.0	2	1.30
	HSK63A-SFH16-95	P2565054	16	27	34	95	50	M12x1.0	2	0.98
	HSK63A-SFH16-160	P2565053	16	27	34	160	50	M12x1.0	2	1.40
	HSK63A-SFH18-95	P2771456	18	33	42	95	50	M12x1.0	2	0.98
	HSK63A-SFH18-160	P2771457	18	33	42	160	50	M12x1.0	2	1.40
	HSK63A-SFH20-100	P2600005	20	33	42	100	52	M16x1.0	2	1.00
	HSK63A-SFH20-160	P2565055	20	33	42	160	52	M16x1.0	2	1.40
	HSK63A-SFH25-115	P2771458	25	44	53	115	58	M16x1.0	2	1.40
	HSK63A-SFH25-160	P2771459	25	44	53	160	58	M16x1.0	2	1.80

▶ Without balancing screw.

SHRINK FIT HOLDER

SCHRUMPFUTTER
MANDRIN DE FRETAGE
MADRINI PER CALLETAMENTO A CALDO
PORTAHERRAMIENTAS DE COMPRESION POR CALOR



DIN 69893/ISO 12164-1-HSK FORM A

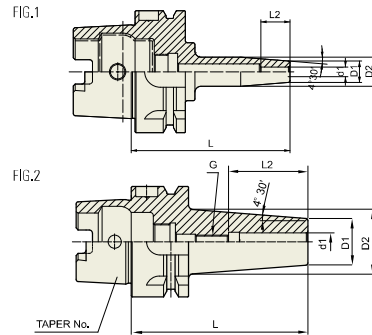

DIN 69893 - HSK	Taper Accuracy -	G Value 2.5	RPM 25,000	Run-Out (I.D) ≤3Um	Coolant System AD
-----------------	------------------	-------------	------------	--------------------	-------------------

TAPER No.	MODEL No.	EDP No.	d1	D1	D2	L	L2	G	FIG.	WEIGHT (Kg)
80A	HSK80A-SFH6-85	P2771460	6	21	27	85	36	M5x0.8	2	
	HSK80A-SFH8-85	P2771461	8	21	27	85	36	M6x1.0	2	
	HSK80A-SFH10-90	P2771462	10	24	32	90	41	M8x1.0	2	
	HSK80A-SFH12-95	P2771463	12	24	32	95	46	M10x1.0	2	
	HSK80A-SFH14-95	P2771464	14	27	34	95	46	M10x1.0	2	
	HSK80A-SFH16-100	P2771465	16	27	34	100	49	M12x1.0	2	
	HSK80A-SFH18-100	P2771466	18	33	42	100	49	M12x1.0	2	
	HSK80A-SFH20-105	P2771467	20	33	42	105	51	M16x1.0	2	
	HSK80A-SFH25-115	P2771468	25	44	53	115	57	M16x1.0	2	
	HSK100A-SFH3-85	P2771469	3	11	15	85	10	-	1	1.30
HSK100A-SFH4-85	P2771470	4	11	15	85	12	-	1	1.30	
HSK100A-SFH5-85	P2771471	5	11	15	85	15	-	1	1.30	
HSK100A-SFH6-85	P2777301	6	21	27	85	36	M5x0.8	2	1.30	
HSK100A-SFH6-160	P2771472	6	21	27	160	36	M5x0.8	2	1.80	
HSK100A-SFH8-85	P2777302	8	21	27	85	36	M6x1.0	2	1.30	
HSK100A-SFH8-160	P2771473	8	21	27	160	36	M6x1.0	2	1.80	
HSK100A-SFH10-90	P2777303	10	24	32	90	42	M8x1.0	2	1.30	
HSK100A-SFH10-160	P2771474	10	24	32	160	42	M8x1.0	2	1.80	
HSK100A-SFH12-95	P2777304	12	24	32	95	47	M10x1.0	2	1.30	
HSK100A-SFH12-160	P2771475	12	24	32	160	47	M10x1.0	2	1.80	
HSK100A-SFH14-95	P2771476	14	27	34	95	47	M10x1.0	2	1.40	
HSK100A-SFH14-160	P2771477	14	27	34	160	47	M10x1.0	2	1.90	
HSK100A-SFH16-100	P2771478	16	27	34	100	50	M12x1.0	2	1.40	
HSK100A-SFH16-160	P2771479	16	27	34	160	50	M12x1.0	2	1.90	
HSK100A-SFH18-100	P2771480	18	33	42	100	50	M12x1.0	2	1.50	
HSK100A-SFH18-160	P2771481	18	33	42	160	50	M12x1.0	2	2.00	
HSK100A-SFH20-100	P2771482	20	33	42	100	52	M16x1.0	2	1.50	
HSK100A-SFH20-160	P2771483	20	33	42	160	52	M16x1.0	2	2.00	
HSK100A-SFH25-115	P2771484	25	44	53	115	58	M16x1.0	2	1.80	
HSK100A-SFH25-160	P2771485	25	44	53	160	58	M16x1.0	2	2.30	

▶ Without balancing screw.

SHRINK FIT HOLDER (EXTRA SLIM) NEW

SCHRUMPFUTTER
MANDRIN DE FRETAGE
MADRINI PER CALLETAMENTO A CALDO
PORTAHERRAMIENTAS DE COMPRESION POR CALOR



JIS B6339/MAS 403-BT & CBT (BT DUAL CONTACT)

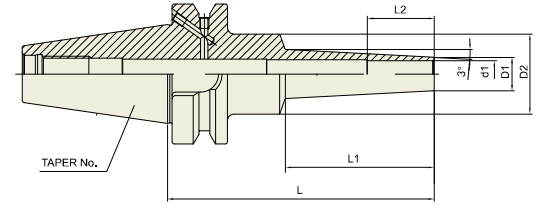

JIS B6339 - BT	Taper Accuracy AT3	G Value 2.5	RPM 25,000	Run-Out (I.D) ≤3Um	Coolant System AD or AD/B
----------------	--------------------	-------------	------------	--------------------	---------------------------

TAPER No.	MODEL No.	EDP No.	d1	D1	D2	L	L1	L2	WEIGHT (Kg)
30	BT30-SFH53-60	P27798515	3	6	20	60	22	9	
	BT30-SFH53-80	P27798525	3	6	20	80	42	9	
	BT30-SFH53-120	P27798535	3	6	20	120	67	9	
	BT30-SFH54-60	P27798545	4	7	20	60	22	12	
	BT30-SFH54-80	P27798555	4	7	20	80	42	12	
	BT30-SFH54-120	P27798565	4	7	20	120	67	12	
	BT30-SFH56-60	P27798575	6	9	20	60	22	18	
	BT30-SFH56-80	P27798585	6	9	20	80	42	18	
	BT30-SFH56-120	P27798595	6	9	20	120	67	18	
	BT40AD/B-SFH53-95	P27798605	3	6	26	95	42	9	
	BT40AD/B-SFH53-120	P27798615	3	6	26	120	67	9	
	BT40AD/B-SFH53-160	P27798625	3	6	26	160	97	9	
40	BT40AD/B-SFH54-95	P27798635	4	7	26	95	42	12	
	BT40AD/B-SFH54-120	P27798645	4	7	26	120	67	12	
	BT40AD/B-SFH54-160	P27798655	4	7	26	160	97	12	
	BT40AD/B-SFH56-95	P27798665	6	9	26	95	42	18	
	BT40AD/B-SFH56-120	P27798675	6	9	26	120	67	18	
	BT40AD/B-SFH56-160	P27798685	6	9	26	160	97	18	
	BT40AD/B-SFH58-95	P27798695	8	11	36	95	42	24	
	BT40AD/B-SFH58-120	P27798705	8	11	36	120	67	24	
	BT40AD/B-SFH58-160	P27798715	8	11	36	160	97	24	
	BT40AD/B-SFH510-95	P27798725	10	13	36	95	42	30	
	BT40AD/B-SFH510-120	P27798735	10	13	36	120	67	30	
	BT40AD/B-SFH510-160	P27798745	10	13	36	160	97	30	
50	BT50AD/B-SFH512-95	P27798755	12	15	36	95	42	30	
	BT50AD/B-SFH512-120	P27798765	12	15	36	120	67	30	
	BT50AD/B-SFH512-160	P27798775	12	15	36	160	97	30	
	BT50AD/B-SFH53-110	P27798785	3	6	26	110	42	9	
	BT50AD/B-SFH53-160	P27798795	3	6	26	160	97	9	
	BT50AD/B-SFH54-110	P27798805	4	7	26	110	42	12	
	BT50AD/B-SFH54-160	P27798815	4	7	26	160	97	12	
	BT50AD/B-SFH56-110	P27798825	6	9	26	110	42	18	
	BT50AD/B-SFH56-160	P27798835	6	9	26	160	97	18	
	BT50AD/B-SFH58-110	P27798845	8	11	36	110	42	24	
	BT50AD/B-SFH58-160	P27798855	8	11	36	160	97	24	
	BT50AD/B-SFH510-110	P27798865	10	13	36	110	42	30	
BT50AD/B-SFH510-160	P27798875	10	13	36	160	97	30		
BT50AD/B-SFH512-110	P27798885	12	15	36	110	42	30		
BT50AD/B-SFH512-160	P27798895	12	15	36	160	97	30		

▶ CBT(BT DUAL CONTACT) Holder available.
▶ CAT(ANSI B5.50) taper and Inch type products are available.

SHRINK FIT HOLDER

SHRINK FIT HOLDER

SCHRUMPFUTTER
MANDRIN DE FRETAGE
MADRINI PER CALLETAMENTO A CALDO
PORTAHERRAMIENTAS DE COMPRESION POR CALOR

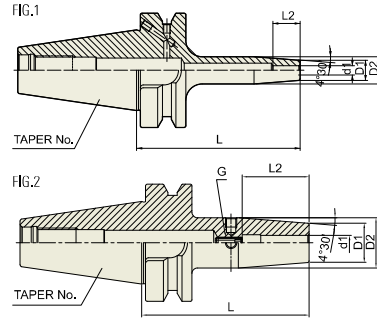

CBT	Taper Accuracy AT3	G Value 2.5	RPM 25,000	Run-Out (I.D.) ≤3Um	Coolant System AD
-----	-----------------------	----------------	---------------	------------------------	----------------------

CBT (BT DUAL CONTACT)

Unit : mm											
TAPER No.	MODEL No.	EDP No.	d1	D1	D2	L	L2	G	FIG.	WEIGHT (Kg)	
30	CBT30-SFH3-60	P2771505	3	11	15	60	10	-	1	0.40	
	CBT30-SFH4-60	P2771506	4	11	15	60	12	-	1	0.40	
	CBT30-SFH5-60	P2771507	5	11	15	60	15	-	1	0.40	
	CBT30-SFH6-60	P2771508	6	21	27	60	36	M5x0.8	2	0.40	
	CBT30-SFH8-60	P2771509	8	21	27	60	36	M6x1.0	2	0.40	
	CBT30-SFH10-80	P2771510	10	24	32	80	41	M8x1.0	2	0.40	
	CBT30-SFH12-80	P2771511	12	24	32	80	48	M10x1.0	2	0.42	
	CBT30-SFH14-80	P2771512	14	27	34	80	48	M10x1.0	2	0.42	
	CBT30-SFH16-80	P2771513	16	27	34	80	51	M12x1.0	2	0.42	
	CBT30-SFH18-80	P2771514	18	27	34	80	51	M12x1.0	2	0.42	
	CBT30-SFH20-90	P2771515	20	33	42	90	53	M16x1.0	2	0.44	
	CBT40-SFH3-90	P2771516	3	11	15	90	10	-	1	1.00	
CBT40-SFH4-90	P2771517	4	11	15	90	12	-	1	1.00		
CBT40-SFH5-90	P2771518	5	11	15	90	23	-	1	1.00		
CBT40-SFH6-90	P2771519	6	21	27	90	36	M5x0.8	2	1.10		
CBT40-SFH6-160	P2771520	6	21	27	160	36	M5x0.8	2	1.15		
CBT40-SFH8-90	P2771501	8	21	27	90	36	M6x1.0	2	1.11		
CBT40-SFH8-160	P2771521	8	21	27	160	36	M6x1.0	2	1.15		
CBT40-SFH10-90	P2771502	10	24	32	90	41	M8x1.0	2	1.10		
CBT40-SFH10-160	P2771522	10	24	32	160	41	M8x1.0	2	1.15		
CBT40-SFH12-90	P2771503	12	24	32	90	47	M10x1.0	2	1.10		
CBT40-SFH12-160	P2771523	12	24	32	160	47	M10x1.0	2	1.15		
CBT40-SFH14-90	P2771524	14	27	34	90	47	M10x1.0	2	1.20		
CBT40-SFH14-160	P2771525	14	27	34	160	47	M10x1.0	2	1.50		
CBT40-SFH16-90	P2771526	16	27	34	90	50	M12x1.0	2	1.20		
CBT40-SFH16-160	P2771527	16	27	34	160	50	M12x1.0	2	1.50		
CBT40-SFH18-90	P2771528	18	33	42	90	50	M12x1.0	2	1.30		
CBT40-SFH18-160	P2771529	18	33	42	160	50	M12x1.0	2	1.60		
CBT40-SFH20-90	P2771504	20	33	42	90	52	M16x1.0	2	1.40		
CBT40-SFH20-160	P2771530	20	33	42	160	52	M16x1.0	2	1.70		
CBT40-SFH25-100	P2771531	25	44	53	100	58	M16x1.0	2	1.70		
CBT40-SFH25-160	P2771532	25	44	53	160	58	M16x1.0	2	2.00		

▶ Without balancing screw.

SHRINK FIT HOLDER

SHRINK FIT HOLDER

SCHRUMPFUTTER
MANDRIN DE FRETAGE
MADRINI PER CALLETAMENTO A CALDO
PORTAHERRAMIENTAS DE COMPRESION POR CALOR

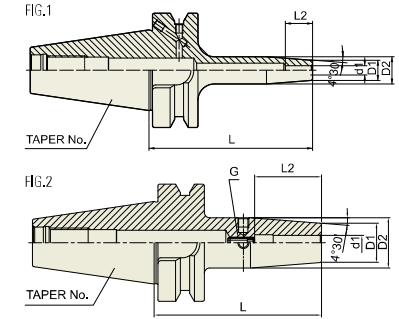

CBT	Taper Accuracy AT3	G Value 2.5	RPM 25,000	Run-Out (I.D.) ≤3Um	Coolant System AD
-----	-----------------------	----------------	---------------	------------------------	----------------------

CBT (BT DUAL CONTACT)

Unit : mm											
TAPER No.	MODEL No.	EDP No.	d1	D1	D2	L	L2	G	FIG.	WEIGHT (Kg)	
50	CBT50-SFH3-100	P2771533	3	11	15	100	10	-	1	1.50	
	CBT50-SFH4-100	P2771534	4	11	15	100	12	-	1	1.50	
	CBT50-SFH5-100	P2771535	5	11	15	100	15	-	1	1.50	
	CBT50-SFH6-100	P2771536	6	21	27	100	36	M5x0.8	2	1.50	
	CBT50-SFH6-160	P2771537	6	21	27	160	36	M5x0.8	2	2.00	
	CBT50-SFH8-100	P2771538	8	21	27	100	36	M6x1.0	2	1.50	
	CBT50-SFH8-160	P2771539	8	21	27	160	36	M6x1.0	2	2.00	
	CBT50-SFH10-100	P2771540	10	24	32	100	42	M8x1.0	2	1.50	
	CBT50-SFH10-160	P2771541	10	24	32	160	42	M8x1.0	2	2.00	
	CBT50-SFH12-100	P2771542	12	24	32	100	47	M10x1.0	2	1.50	
	CBT50-SFH12-160	P2771543	12	24	32	160	47	M10x1.0	2	2.00	
	CBT50-SFH14-100	P2771544	14	27	34	100	47	M10x1.0	2	1.60	
	CBT50-SFH14-160	P2771545	14	27	34	160	47	M10x1.0	2	2.10	
	CBT50-SFH16-100	P2771546	16	27	34	100	50	M12x1.0	2	1.60	
	CBT50-SFH16-160	P2771547	16	27	34	160	50	M12x1.0	2	2.10	
	CBT50-SFH18-100	P2771548	18	33	42	100	50	M12x1.0	2	1.60	
	CBT50-SFH18-160	P2771549	18	33	42	160	50	M12x1.0	2	2.00	
	CBT50-SFH20-100	P2771550	20	33	42	100	52	M16x1.0	2	1.80	
	CBT50-SFH20-160	P2771551	20	33	42	160	52	M16x1.0	2	2.20	
	CBT50-SFH25-100	P2771552	25	44	53	100	58	M16x1.0	2	2.00	
CBT50-SFH25-160	P2771553	25	44	53	160	58	M16x1.0	2	2.40		

▶ Without balancing screw.

SHRINK FIT HOLDER

SCHRUMPFUTTER
MANDRIN DE FRETAGE
MADRINI PER CALLETAMENTO A CALDO
PORTAHERRAMIENTAS DE COMPRESION POR CALOR

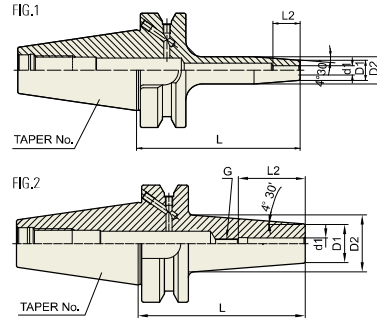

JIS B6339 -BT	Taper Accuracy AT3	G Value 2.5	RPM 25,000	Run-Out (I.D) ≤3Um	Coolant System AD or AD/B
------------------	--------------------------	----------------	---------------	--------------------------	---------------------------------

JIS B6339/MAS 403-BT

Unit : mm										
TAPER No.	MODEL No.	EDP No.	d1	D1	D2	L	L2	G	FIG.	WEIGHT (Kg)
30	BT30-SFH3-60	P2776703A	3	11	15	60	10	-	1	0.40
	BT30-SFH4-60	P2776702A	4	11	15	60	12	-	1	0.40
	BT30-SFH5-60	P2776704A	5	11	15	60	15	-	1	0.40
	BT30-SFH6-60	P2776701A	6	21	27	60	36	M5x0.8	2	0.40
	BT30-SFH8-60	P2776705A	8	21	27	60	36	M6x1.0	2	0.40
	BT30-SFH10-80	P2776706A	10	24	32	80	42	M8x1.0	2	0.40
	BT30-SFH12-80	P2776707A	12	24	32	80	47	M10x1.0	2	0.42
	BT30-SFH14-80	P2776708A	14	27	34	80	47	M10x1.0	2	0.42
	BT30-SFH16-80	P2776709A	16	27	34	80	50	M12x1.0	2	0.42
	BT30-SFH18-80	P2776710A	18	33	42	80	50	M12x1.0	2	0.44
	BT30-SFH20-90	P2776711A	20	33	42	90	52	M16x1.0	2	0.44
	BT40AD/B-SFH3-90	P2776712	3	11	15	90	10	-	1	1.00
BT40AD/B-SFH4-90	P2776713	4	11	15	90	12	-	1	1.00	
BT40AD/B-SFH5-90	P2776714	5	11	15	90	15	-	1	1.00	
BT40AD/B-SFH6-90	P2771601	6	21	27	90	36	M5x0.8	2	1.10	
BT40AD/B-SFH6-160	P2771602	6	21	27	160	36	M5x0.8	2	1.15	
BT40AD/B-SFH8-90	P2771603	8	21	27	90	36	M6x1.0	2	1.11	
BT40AD/B-SFH8-160	P2771604	8	21	27	160	36	M6x1.0	2	1.15	
BT40AD/B-SFH10-90	P2771605	10	24	32	90	42	M8x1.0	2	1.10	
BT40AD/B-SFH10-160	P2771606	10	24	32	160	42	M8x1.0	2	1.15	
BT40AD/B-SFH12-90	P2771607	12	24	32	90	47	M10x1.0	2	1.10	
BT40AD/B-SFH12-160	P2771608	12	24	32	160	47	M10x1.0	2	1.15	
BT40AD/B-SFH14-90	P2771611	14	27	34	90	47	M10x1.0	2	1.20	
BT40AD/B-SFH14-160	P2771612	14	27	34	160	47	M10x1.0	2	1.50	
BT40AD/B-SFH16-90	P2771609	16	27	34	90	50	M12x1.0	2	1.20	
BT40AD/B-SFH16-160	P2771610	16	27	34	160	50	M12x1.0	2	1.50	
BT40AD/B-SFH18-90	P2771613	18	33	42	90	50	M12x1.0	2	1.30	
BT40AD/B-SFH18-160	P2771614	18	33	42	160	50	M12x1.0	2	1.60	
BT40AD/B-SFH20-90	P2771615	20	33	42	90	52	M16x1.0	2	1.40	
BT40AD/B-SFH20-160	P2771616	20	33	42	160	52	M16x1.0	2	1.70	
BT40AD/B-SFH25-100	P2771617	25	44	53	100	58	M16x1.0	2	1.70	
BT40AD/B-SFH25-160	P2771618	25	44	53	160	58	M16x1.0	2	2.00	

▶ CAT(ANSI B5.50) taper and Inch type products are available.
▶ Without balancing screw.

SHRINK FIT HOLDER

SCHRUMPFUTTER
MANDRIN DE FRETAGE
MADRINI PER CALLETAMENTO A CALDO
PORTAHERRAMIENTAS DE COMPRESION POR CALOR

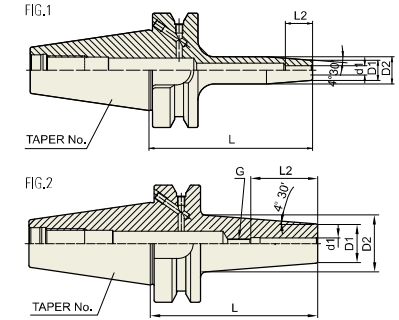

JIS B6339 -BT	Taper Accuracy AT3	G Value 2.5	RPM 25,000	Run-Out (I.D) ≤3Um	Coolant System AD/B
------------------	--------------------------	----------------	---------------	--------------------------	---------------------------

JIS B6339/MAS 403-BT

Unit : mm										
TAPER No.	MODEL No.	EDP No.	d1	D1	D2	L	L2	G	FIG.	WEIGHT (Kg)
50	BT50AD/B-SFH3-100	P2771619	3	11	15	100	10	-	1	1.50
	BT50AD/B-SFH4-100	P2771620	4	11	15	100	12	-	1	1.50
	BT50AD/B-SFH5-100	P2771621	5	11	15	100	15	-	1	1.50
	BT50AD/B-SFH6-100	P2771622	6	21	27	100	36	M5x0.8	2	1.50
	BT50AD/B-SFH6-160	P2771623	6	21	27	160	36	M5x0.8	2	2.00
	BT50AD/B-SFH8-100	P2771624	8	21	27	100	36	M6x1.0	2	1.50
	BT50AD/B-SFH8-160	P2771625	8	21	27	160	36	M6x1.0	2	2.00
	BT50AD/B-SFH10-100	P2771626	10	24	32	100	42	M8x1.0	2	1.50
	BT50AD/B-SFH10-160	P2771627	10	24	32	160	42	M8x1.0	2	2.00
	BT50AD/B-SFH12-100	P2771628	12	24	32	100	47	M10x1.0	2	1.50
	BT50AD/B-SFH12-160	P2771629	12	24	32	160	47	M10x1.0	2	2.00
	BT50AD/B-SFH14-100	P2771630	14	27	34	100	47	M10x1.0	2	1.60
	BT50AD/B-SFH14-160	P2771631	14	27	34	160	47	M10x1.0	2	2.10
	BT50AD/B-SFH16-100	P2771632	16	27	34	100	50	M12x1.0	2	1.60
	BT50AD/B-SFH16-160	P2771633	16	27	34	160	50	M12x1.0	2	2.10
	BT50AD/B-SFH18-100	P2771634	18	33	42	100	50	M12x1.0	2	1.60
	BT50AD/B-SFH18-160	P2771635	18	33	42	160	50	M12x1.0	2	2.00
	BT50AD/B-SFH20-100	P2771636	20	33	42	100	52	M16x1.0	2	1.80
	BT50AD/B-SFH20-160	P2771637	20	33	42	160	52	M16x1.0	2	2.20
	BT50AD/B-SFH25-100	P2771638	25	44	53	100	58	M16x1.0	2	2.00
	BT50AD/B-SFH25-160	P2771639	25	44	53	160	58	M16x1.0	2	2.40

▶ CAT(ANSI B5.50) taper and Inch type products are available.
▶ Without balancing screw.

SHRINK FIT HOLDER

SHRINK FIT HOLDER **NEW**

SCHRUMPFUTTER
MANDRIN DE FRETAGE
MADRINI PER CALLETAMENTO A CALDO
PORTAHERRAMIENTAS DE COMPRESION POR CALOR

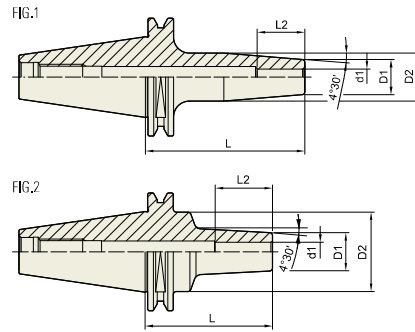

ISO 25	Taper Accuracy AT3	G Value 2.5	RPM 30,000	Run-Out (I.D.) ≤3Uμm	Coolant System AD
--------	-----------------------	----------------	---------------	-------------------------	----------------------

ISO 25

Unit : mm

TAPER No.	MODEL No.	EDP No.	d1	D1	D2	L	L2	FIG.	WEIGHT (Kg)
25	ISO25-SFH3-50	P2771651	3	11	15	50	10	1	
	ISO25-SFH4-50	P2771652	4	11	15	50	12	1	
	ISO25-SFH5-50	P2771653	5	11	15	50	15	1	
	ISO25-SFH6-40	P2771654	6	12	17	40	18	2	
	ISO25-SFH8-50	P2771655	8	14	18	50	30	2	
	ISO25-SFH10-50	P2771656	10	16	20	50	37	2	

- ▶ Higher balancing grade is available upon request.
- ▶ To be supplied with assembling of pull stud bolt.

SFH

SHRINK FIT HOLDER

SHRINK FIT HOLDER (EXTENSION)

SCHRUMPFUTTER (VERLÄGERUNG)
MANDRIN DE FRETAGE (EXTENSION)
MADRINI PER CALLETAMENTO A CALDO (PROLUNGHE)
PORTAHERRAMIENTAS DE COMPRESION POR CALOR (EXTENSION)

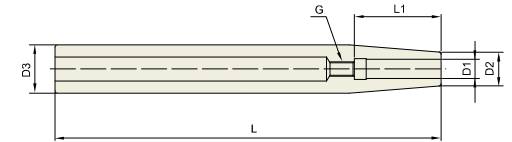

STANDARD

Unit : mm

TAPER No.	MODEL No.	EDP No.	D1	D2	D3	L	L2	G	WEIGHT (Kg)
12	ST12-SFH3-120	P2767010	3	8	12	19	120	-	
	ST12-SFH4-120	P2767015	4	8	12	22	120	-	
	ST12-SFH5-120	P2771701	5	10	12	28	120	-	
	ST12-SFH6-120	P2771709	6	10	12	36	120	M5x0.8	
	ST16-SFH3-120	P2767110	3	10	16	19	120	-	
	ST16-SFH4-120	P2767115	4	10	16	22	120	-	
16	ST16-SFH5-120	P2771702	5	10	16	28	120	-	
	ST16-SFH6-120	P2771710	6	10	16	36	120	M5x0.8	
	ST16-SFH8-120	P2771711	8	12	16	36	120	M6x1.0	
	ST20-SFH3-120	P2771703	3	10	20	19	120	-	
20	ST20-SFH4-120	P2771704	4	10	20	22	120	-	
	ST20-SFH5-120	P2771705	5	10	20	28	120	-	
	ST20-SFH6-120	P2771712	6	10	20	36	120	M5x0.8	
	ST20-SFH8-120	P2771713	8	12	20	36	120	M6x1.0	
	ST20-SFH10-120	P2771714	10	14	20	42	120	M8x1.0	
	ST20-SFH12-120	P2771715	12	16	20	47	120	M10x1.0	

- ▶ Inch type products are available.

SFH

SHRINK FIT HOLDER (EXTENSION)

SFH

SCHRUMPFUTTER (VERLÄGERUNG)
 MANDRIN DE FRETAGE (EXTENSION)
 MADRINI PER CALLETAMENTO A CALDO (PROLUNGHE)
 PORTAHERRAMIENTAS DE COMPRESION POR CALOR (EXTENSION)

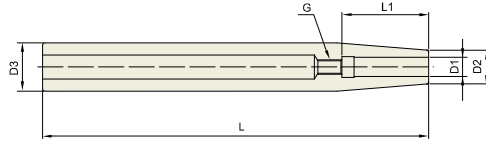

STANDARD

Unit : mm									
TAPER No.	MODEL No.	EDP No.	D1	D2	D3	L	L2	G	WEIGHT (Kg)
12	ST12-SFH3-160	P2767020	3	8	12	19	160	-	
	ST12-SFH4-160	P2767025	4	8	12	22	160	-	
	ST12-SFH5-160	P2771706	5	10	12	28	160	-	
16	ST12-SFH6-160	P2767030	6	10	12	36	160	M5x0.8	
	ST16-SFH3-160	P2767120	3	10	16	19	160	-	
	ST16-SFH4-160	P2767125	4	10	16	22	160	-	
20	ST16-SFH5-160	P2771707	5	10	16	28	160	-	
	ST16-SFH6-160	P2767130	6	10	16	36	160	M5x0.8	
	ST16-SFH8-160	P2767135	8	12	16	36	160	M6x1.0	
25	ST20-SFH3-160	P2767210	3	10	20	19	160	-	
	ST20-SFH4-160	P2767215	4	10	20	22	160	-	
	ST20-SFH5-160	P2771708	5	10	20	28	160	-	
32	ST20-SFH6-160	P2767220	6	10	20	36	160	M5x0.8	
	ST20-SFH8-160	P2767225	8	12	20	36	160	M6x1.0	
	ST20-SFH10-160	P2767230	10	14	20	42	160	M8x1.0	
40	ST20-SFH12-160	P2767235	12	16	20	47	160	M10x1.0	
	ST25-SFH3-160	P2771716	3	10	25	19	160	-	
	ST25-SFH4-160	P2771717	4	10	25	22	160	-	
50	ST25-SFH5-160	P2771718	5	15	25	28	160	-	
	ST25-SFH6-160	P2771719	6	20	25	36	160	M5x0.8	
	ST25-SFH8-160	P2771720	8	20	25	36	160	M6x1.0	
63	ST25-SFH10-160	P2771721	10	20	25	42	160	M8x1.0	
	ST25-SFH12-160	P2771722	12	20	25	47	160	M10x1.0	
	ST25-SFH14-160	P2771723	14	20	25	47	160	M10x1.0	
80	ST25-SFH16-160	P2771724	16	22	25	50	160	M12x1.0	
	ST32-SFH6-160	P2771725	6	20	32	36	160	M5x0.8	
	ST32-SFH8-160	P2771726	8	20	32	36	160	M6x1.0	
100	ST32-SFH10-160	P2771727	10	24	32	42	160	M8x1.0	
	ST32-SFH12-160	P2771728	12	24	32	47	160	M10x1.0	
	ST32-SFH14-160	P2771729	14	27	32	47	160	M10x1.0	
125	ST32-SFH16-160	P2771730	16	27	32	50	160	M12x1.0	
	ST32-SFH18-160	P2771731	18	27	32	50	160	M12x1.0	
	ST32-SFH20-160	P2771732	20	27	32	52	160	M16x1.0	

▶ Inch type products are available.

SHRINK FIT HEATING MACHINE

SFH

TECHINCAL INFORMATION

FEATURE

- ▶ Electromagnetic induction heating system
- ▶ Automatic voltage adjustment : AC 100V~240V
- ▶ Small size and light weight
- ▶ Easy to operate

SPECIFICATION

CHARACTERISTICS	SPECIFICATION
MODEL No.	SF-2200
EDP No.	P2781001
Power	100V~240V AC, 50/60Hz, Max. 3.6KW
Dimension	380(W) x 350(D) x 720(H)mm
Weight	22Kg
Holder Support	SK, HSK, BT

