

YG-1 TOOLING SYSTEM

FACE MILL ARBOR

- AUFNAHMEDORN FÜR MESSERKÖPFE
- ARBRE PORTE FRAISE À ALÉSAGE
- MANDRINO PORTA FRESE FRONTALE
- EJE PARA PLATOS DE PLACAS



CBT (BT DUAL CONTACT)

FMA

JIS B6339/MAS 403-BT

FMA

DIN 69893/ISO 12164-1-HSK

FMA

ANSI B5.18-NT

FMA

DIN 228-MTA

CBT (BT DUAL CONTACT)

FMB / FMC

JIS B6339/MAS 403-BT

FMB / FMC

DIN 69893/ISO 12164-1-HSK

FMC

FACE MILL ARBOR

AUFNAHMEDORN FÜR MESSERKÖPFE
ARBRE PORTE FRAISE À ALESAGE
MANDRINO PORTA FRESE FRONTALE

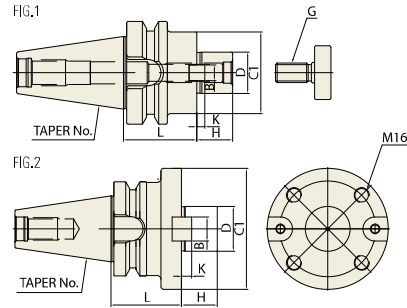

CBT	Taper Accuracy AT3	G Value 2.5	RPM 25,000	Coolant System A
-----	-----------------------	----------------	---------------	---------------------

CBT (BT DUAL CONTACT)

Unit : mm

TAPER No.	MODEL No.	EDP No.	D	L	C1	H	B	K	G	FIG.	WEIGHT (Kg)
30	CBT30-FMA25.4-45	P2779201	25.4	45	50	22	9.5	5	M12	1	1.10
	CBT30-FMA31.75-45	P2779202	31.75	45	60	30	12.7	7	M16	1	1.20
	CBT40-FMA25.4-45	P2779203	25.4	45	50	22	9.5	5	M12	1	1.50
40	CBT40-FMA25.4-90	P2779204	25.4	90	50	22	9.5	5	M12	1	3.10
	CBT40-FMA31.75-45	P2779205	31.75	45	60	30	12.7	7	M16	1	1.90
	CBT40-FMA31.75-75	P2779206	31.75	75	60	30	12.7	7	M16	1	2.70
	CBT40-FMA38.1-60	P2779207	38.1	60	80	34	15.9	9	M20	1	2.90
	CBT50-FMA25.4-45	P2779208	25.4	45	50	22	9.5	5	M12	1	3.70
	CBT50-FMA25.4-90	P2779209	25.4	90	50	22	9.5	5	M12	1	4.60
50	CBT50-FMA25.4-150	P2779210	25.4	150	50	22	9.5	5	M12	1	5.50
	CBT50-FMA31.75-45	P2779211	31.75	45	60	30	12.7	7	M16	1	4.50
	CBT50-FMA31.75-75	P2779212	31.75	75	60	30	12.7	7	M16	1	5.30
	CBT50-FMA31.75-105	P2779213	31.75	105	60	30	12.7	7	M16	1	5.80
	CBT50-FMA31.75-150	P2779214	31.75	150	60	30	12.7	7	M16	1	6.30
	CBT50-FMA38.1-45	P2779215	38.1	45	80	34	15.9	9	M20	1	4.30
	CBT50-FMA38.1-75	P2779216	38.1	75	80	34	15.9	9	M20	1	5.60
	CBT50-FMA38.1-105	P2779217	38.1	105	80	34	15.9	9	M20	1	6.00
	CBT50-FMA38.1-150	P2779218	38.1	150	80	34	15.9	9	M20	1	6.50
	CBT50-FMA50.8-45	P2779219	50.8	45	100	36	19.05	10	M24	1	4.90
	CBT50-FMA50.8-75	P2779220	50.8	75	100	36	19.05	10	M24	1	6.80
	CBT50-FMA47.625-75	P2779221	47.625	75	128.57	38	25.4	12.5	-	2	7.70

▶ Through coolant system is optional.
▶ For parts, please refer to page 207.

FACE MILL ARBOR

AUFNAHMEDORN FÜR MESSERKÖPFE
ARBRE PORTE FRAISE À ALESAGE
MANDRINO PORTA FRESE FRONTALE
EJE PARA PLATOS DE PLACAS

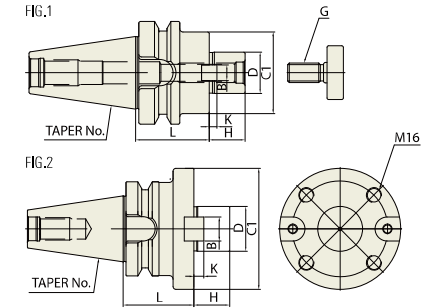

JIS B6339 - BT	Taper Accuracy AT3	G Value 6.3	RPM 15,000	Coolant System A
----------------	-----------------------	----------------	---------------	---------------------

JIS B6339/MAS 403-BT

Unit : mm

TAPER No.	MODEL No.	EDP No.	D	L	C1	H	B	K	G	FIG.	WEIGHT (Kg)
30	BT30-FMA25.4-45	P2779222	25.4	45	50	22	9.5	5	M12	1	1.10
	BT30-FMA31.75-45	P2779223	31.75	45	60	30	12.7	7	M16	1	1.20
	BT40-FMA25.4-45	P2779224	25.4	45	50	22	9.5	5	M12	1	1.50
40	BT40-FMA25.4-90	P2779225	25.4	90	50	22	9.5	5	M12	1	3.10
	BT40-FMA31.75-45	P2779226	31.75	45	60	30	12.7	7	M16	1	1.90
	BT40-FMA31.75-75	P2779227	31.75	75	60	30	12.7	7	M16	1	2.70
	BT40-FMA38.1-60	P2779228	38.1	60	80	34	15.9	9	M20	1	2.90
	BT50-FMA25.4-45	P2779229	25.4	45	50	22	9.5	5	M12	1	3.70
	BT50-FMA25.4-90	P2779230	25.4	90	50	22	9.5	5	M12	1	4.60
50	BT50-FMA25.4-150	P2779231	25.4	150	50	22	9.5	5	M12	1	5.50
	BT50-FMA31.75-45	P2779232	31.75	45	60	30	12.7	7	M16	1	4.50
	BT50-FMA31.75-75	P2779233	31.75	75	60	30	12.7	7	M16	1	5.30
	BT50-FMA31.75-105	P2779234	31.75	105	60	30	12.7	7	M16	1	5.80
	BT50-FMA31.75-150	P2779235	31.75	150	60	30	12.7	7	M16	1	6.30
	BT50-FMA38.1-45	P2779236	38.1	45	80	34	15.9	9	M20	1	4.30
	BT50-FMA38.1-75	P2779237	38.1	75	80	34	15.9	9	M20	1	5.60
	BT50-FMA38.1-105	P2779238	38.1	105	80	34	15.9	9	M20	1	6.00
	BT50-FMA38.1-150	P2779239	38.1	150	80	34	15.9	9	M20	1	6.50
	BT50-FMA50.8-45	P2779240	50.8	45	100	36	19.05	10	M24	1	4.90
	BT50-FMA50.8-75	P2779241	50.8	75	100	36	19.05	10	M24	1	6.80
	BT50-FMA47.625-75	P2779242	47.625	75	128.57	38	25.4	12.5	-	2	7.70

▶ Through coolant system is optional.
▶ CAT(ANSI B5.50) taper and Inch type products are available.
▶ For parts, please refer to page 207.

FACE MILL ARBOR

FMA

AUFNAHMEDORN FÜR MESSERKÖPFE
ARBRE PORTE FRAISE À ALÉSAGE
MANDRINO PORTA FRESE FRONTALE
EJE PARA PLATOS DE PLACAS

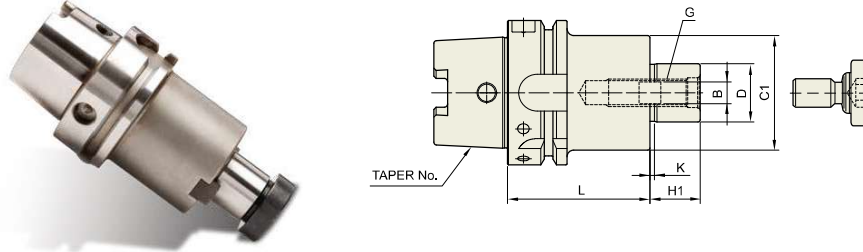

DIN 69893 -HSK	Taper Accuracy -	G Value 6.3	RPM 15,000	Coolant System A
-------------------	---------------------	----------------	---------------	---------------------

■ DIN 69893/ISO 12164-1-HSK FORM A

Unit : mm

TAPER No.	MODEL No.	EDP No.	D	C1	L	H1	B	K	G	WEIGHT (Kg)
40A	HSK40A-FMA25.4-50	P2779243	25.4	50	50	22	9.5	5	M12	
50A	HSK50A-FMA25.4-60	P2779244	25.4	50	60	22	9.5	5	M12	
63A	HSK63A-FMA25.4-45	P2779245	25.4	50	45	22	9.5	5	M12	
	HSK63A-FMA31.75-50	P2779246	31.75	60	50	30	12.7	7	M16	
100A	HSK100A-FMA25.4-45	P2779247	25.4	50	45	22	9.5	5	M12	
	HSK100A-FMA31.75-50	P2779248	31.75	60	50	30	12.7	7	M16	
	HSK100A-FMA38.1-55	P2779249	38.1	80	55	34	15.9	9	M20	
	HSK100A-FMA50.8-60	P2779250	50.8	100	60	36	19.05	10	M24	

- ▶ Through coolant system is optional.
- ▶ For parts, please refer to page 207.

FACE MILL ARBOR

FMA

AUFNAHMEDORN FÜR MESSERKÖPFE
ARBRE PORTE FRAISE À ALÉSAGE
MANDRINO PORTA FRESE FRONTALE
EJE PARA PLATOS DE PLACAS

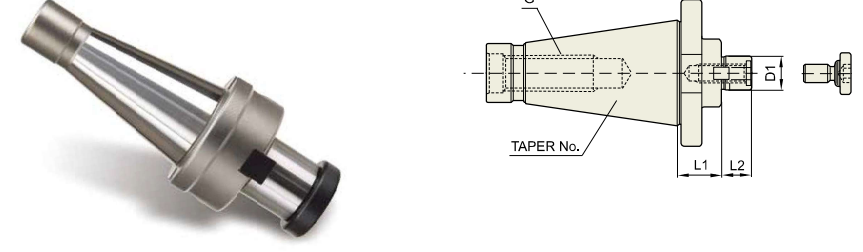

DIN 2080 -NT	Taper Accuracy AT3	G Value -	RPM -	Coolant System A
-----------------	-----------------------	--------------	----------	---------------------

■ ANSI B5.18-NT

Unit : mm

TAPER No.	MODEL No.	EDP No.	CUTTER (Ø)	D1	L1	L2	DRAW THREAD	OLD MODEL No.	WEIGHT (Kg)
40	NT40-FMA25.4	P2779251	3"(75)	25.4	30	22	U5/8-11(M16x2)	NT40-3R	1.45
	NT40-FMA31.75	P2779252	4"(100)	31.75	30	30	U5/8-11(M16x2)	NT40-4R	1.75
	NT40-FMA38.1	P2779253	5"(125)	38.1	30	34	U5/8-11(M16x2)	NT40-5R	1.93
	NT40-FMA50.8	P2779254	6"(150)	50.8	30	36	U5/8-11(M16x2)	NT40-6R	2.55
50	NT50-FMA25.4	P2779255	3"(75)	25.4	30	22	U1-8(M24x3)	NT50-3R	3.30
	NT50-FMA31.75	P2779256	4"(100)	31.75	30	30	U1-8(M24x3)	NT50-4R	3.40
	NT50-FMA38.1	P2779257	5"(125)	38.1	30	34	U1-8(M24x3)	NT50-5R	3.60
	NT50-FMA50.8	P2779258	6"(150)	50.8	30	36	U1-8(M24x3)	NT50-6R	3.90
	NT50-FMA47.625	P2779259	8"(200)	47.625	45	38	U1-8(M24x3)	NT50-8R	4.90

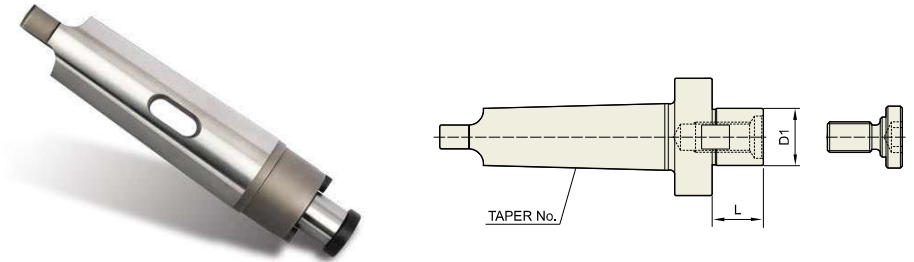

■ DIN 228-MTA

Unit : mm

TAPER No.	MODEL No.	EDP No.	CUTTER (Ø)	D1	L	WEIGHT (Kg)
5	MTA5-FMA25.4	P2779260	3"(75)	25.4	22	1.60
	MTA5-FMA31.75	P2779261	4"(100)	31.75	30	1.90
	MTA5-FMA38.1	P2779262	5"(125)	38.1	34	2.20
6	MTA6-FMA25.4	P2779263	3"(75)	25.4	22	3.50
	MTA6-FMA31.75	P2779264	4"(100)	31.75	30	3.80
	MTA6-FMA38.1	P2779265	5"(125)	38.1	34	4.10
	MTA6-FMA50.8	P2779266	6"(150)	50.8	36	4.60
	MTA6-FMA47.625	P2779267	8"(200)	47.625	38	5.40

- ▶ For parts, please refer to page 207.

FACE MILL ARBOR

FMB

AUFNAHMEDORN FÜR MESSERKÖPFE
ARBRE PORTE FRAISE À ALÉSAGE
MANDRINO PORTA FRESE FRONTALE
EJE PARA PLATOS DE PLACAS

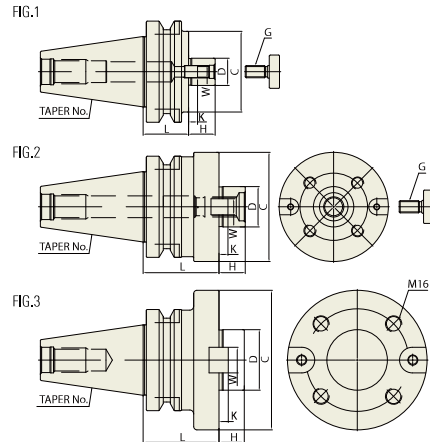

CBT	Taper Accuracy AT3	G Value 2.5	RPM 25,000	Coolant System A
-----	-----------------------	----------------	---------------	---------------------

■ CBT (BT DUAL CONTACT)

◆ METRIC TYPE

Unit : mm

TAPER No.	MODEL No.	EDP No.	D	L	C	H	W	K	G	FIG.	WEIGHT (Kg)
30	CBT30-FMB27-45	P2779268	27	45	80	26	12	6	M12	1	2.10
	CBT40-FMB27-60	P2779269	27	60	80	26	12	6	M12	1	2.50
40	CBT40-FMB27-90	P2779270	27	90	80	26	12	6	M12	1	4.70
	CBT40-FMB40-60	P2779271	40	60	85	26	16	8.5	M20	1	7.40
	CBT50-FMB27-45	P2779272	27	45	80	26	12	6	M12	1	4.00
50	CBT50-FMB27-90	P2779273	27	90	80	26	12	6	M12	1	5.80
	CBT50-FMB27-150	P2779274	27	150	80	26	12	6	M12	1	8.20
	CBT50-FMB40-45	P2779275	40	45	85	26	16	8.5	M20	1	4.70
	CBT50-FMB40-75	P2779276	40	75	85	26	16	8.5	M20	1	6.10
	CBT50-FMB40-105	P2779277	40	105	85	26	16	8.5	M20	1	8.10
	CBT50-FMB40F-75	P2779278	40	75	110	26	16	8.5	M20	2	6.60
	CBT50-FMB60-75	P2779279	60	75	140	25	25.4	12.5	-	3	7.90

◆ INCH TYPE

Unit : mm

TAPER No.	MODEL No.	EDP No.	D	L	C	H	W	K	G	FIG.	WEIGHT (Kg)
30	CBT30-FMB25.4-45	P2779314	25.4	45	80	26	9.5	5	M12	1	2.10
	CBT40-FMB25.4-60	P2779281	25.4	60	80	26	9.5	5	M12	1	2.50
40	CBT40-FMB25.4-90	P2779282	25.4	90	80	26	9.5	5	M12	1	4.70
	CBT40-FMB38.1-60	P2779283	38.1	60	85	26	15.9	9	M20	1	7.40
	CBT50-FMB25.4-45	P2779284	25.4	45	80	26	9.5	5	M12	1	4.00
50	CBT50-FMB25.4-90	P2779285	25.4	90	80	26	9.5	5	M12	1	5.80
	CBT50-FMB25.4-150	P2779286	25.4	150	80	26	9.5	5	M12	1	8.20
	CBT50-FMB38.1-45	P2779287	38.1	45	85	26	15.9	9	M20	1	4.70
	CBT50-FMB38.1-75	P2779288	38.1	75	85	26	15.9	9	M20	1	6.10
	CBT50-FMB38.1-105	P2779289	38.1	105	85	26	15.9	9	M20	1	8.70
	CBT50-FMB38.F-75	P2779290	38.1	75	110	26	15.9	9	M20	2	6.60

▶ Through coolant system is optional.
▶ For parts, please refer to page 207.

FACE MILL ARBOR

FMB

AUFNAHMEDORN FÜR MESSERKÖPFE
ARBRE PORTE FRAISE À ALÉSAGE
MANDRINO PORTA FRESE FRONTALE
EJE PARA PLATOS DE PLACAS

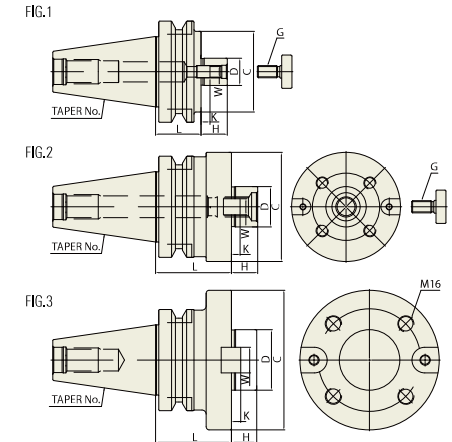

JIS B6339 -BT	Taper Accuracy AT3	G Value 6.3	RPM 15,000	Coolant System A
------------------	-----------------------	----------------	---------------	---------------------

■ JIS B6339/MAS 403-BT

◆ METRIC TYPE

Unit : mm

TAPER No.	MODEL No.	EDP No.	D	L	C	H	W	K	G	FIG.	WEIGHT (Kg)
30	BT30-FMB27-45	P2779291	27	45	80	26	12	6	M12	1	2.10
	BT40-FMB27-60	P2779292	27	60	80	26	12	6	M12	1	2.50
40	BT40-FMB27-90	P2779293	27	90	80	26	12	6	M12	1	4.70
	BT40-FMB40-60	P2779294	40	60	85	26	16	8.5	M20	1	7.40
	BT50-FMB27-45	P2779295	27	45	80	26	12	6	M12	1	4.00
50	BT50-FMB27-90	P2779296	27	90	80	26	12	6	M12	1	5.80
	BT50-FMB27-150	P2779297	27	150	80	26	12	6	M12	1	8.20
	BT50-FMB40-45	P2779298	40	45	85	26	16	8.5	M20	1	4.70
	BT50-FMB40-75	P2779299	40	75	85	26	16	8.5	M20	1	6.10
	BT50-FMB40-105	P2779300	40	105	85	26	16	8.5	M20	1	8.10
	BT50-FMB40F-75	P2779301	40	75	110	26	16	8.5	M20	2	6.60
	BT50-FMB60-75	P2779302	60	75	140	25	25.4	12.5	-	3	7.90

◆ INCH TYPE

Unit : mm

TAPER No.	MODEL No.	EDP No.	D	L	C	H	W	K	G	FIG.	WEIGHT (Kg)
30	BT30-FMB25.4-45	P2779315	25.4	45	80	26	9.5	5	M12	1	2.10
	BT40-FMB25.4-60	P2779304	25.4	60	80	26	9.5	5	M12	1	2.50
40	BT40-FMB25.4-90	P2779305	25.4	90	80	26	9.5	5	M12	1	4.70
	BT40-FMB38.1-60	P2779306	38.1	60	85	26	15.9	9	M20	1	7.40
	BT50-FMB25.4-45	P2779307	25.4	45	80	26	9.5	5	M12	1	4.00
50	BT50-FMB25.4-90	P2779308	25.4	90	80	26	9.5	5	M12	1	5.80
	BT50-FMB25.4-150	P2779309	25.4	150	80	26	9.5	5	M12	1	8.20
	BT50-FMB38.1-45	P2779310	38.1	45	85	26	15.9	9	M20	1	4.70
	BT50-FMB38.1-75	P2779311	38.1	75	85	26	15.9	9	M20	1	6.10
	BT50-FMB38.1-105	P2779312	38.1	105	85	26	15.9	9	M20	1	8.70
	BT50-FMB38.F-75	P2779313	38.1	75	110	26	15.9	9	M20	2	6.60

▶ Through coolant system is optional.
▶ CAT(ANSI B5.50) taper and Inch type products are available.
▶ For parts, please refer to page 207.

FACE MILL ARBOR

FMC

AUFNAHMEDORN FÜR MESSERKÖPFE
ARBRE PORTE FRAISE A ALESAGE
MANDRINO PORTA FRESE FRONTALE
EJE PARA PLATOS DE PLACAS

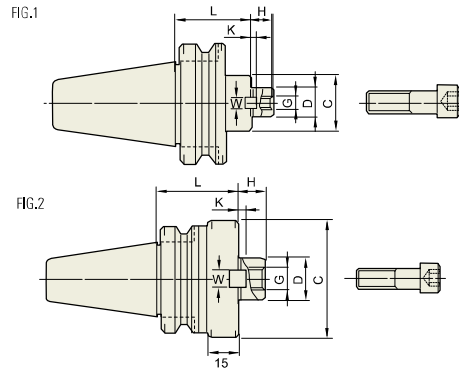

CBT	Taper Accuracy AT3	G Value 2.5	RPM 25,000	Coolant System A
-----	-----------------------	----------------	---------------	---------------------

CBT (BT DUAL CONTACT)

◆ METRIC TYPE

TAPER No.	MODEL No.	EDP No.	D	L	C	H	W	K	G	FIG.	WEIGHT (Kg)
30	CBT30-FMC22-45	P2776131	22	45	45	18	10	5	M10	2	0.80
	CBT40-FMC22-45	P2776132	22	45	45	18	10	5	M10	1	1.30
40	CBT40-FMC27-60	P2776133	27	60	70	20	12	6	M12	2	1.50
	CBT40-FMC32-60	P2776134	32	60	85	22	14	7	M16	2	2.30
50	CBT50-FMC22-60	P2776135	22	60	45	18	10	5	M10	1	4.20
	CBT50-FMC22-105	P2776136	22	105	45	18	10	5	M10	1	4.70
	CBT50-FMC22-150	P2776137	22	150	45	18	10	5	M10	1	5.30
	CBT50-FMC27-45	P2776138	27	45	70	20	12	6	M12	1	4.10
	CBT50-FMC27-90	P2776139	27	90	70	20	12	6	M12	1	5.50
	CBT50-FMC27-150	P2776140	27	150	70	20	12	6	M12	1	7.30
	CBT50-FMC32-60	P2776141	32	60	85	22	14	7	M16	1	4.20
	CBT50-FMC32-105	P2776142	32	105	85	22	14	7	M16	1	5.50
	CBT50-FMC32-150	P2776143	32	150	85	22	14	7	M16	1	7.00

◆ INCH TYPE

TAPER No.	MODEL No.	EDP No.	D	L	C	H	W	K	G	FIG.	WEIGHT (Kg)
30	CBT30-FMC25.4-45	P2776144	25.4	45	70	20	9.5	6	M12	2	1.10
	CBT40-FMC25.4-60	P2776145	25.4	60	70	20	9.5	6	M12	2	1.50
40	CBT40-FMC25.4-90	P2776146	25.4	90	70	20	9.5	6	M12	2	2.20
	CBT40-FMC38.1-60	P2776147	38.1	60	85	22	15.9	7	M16	2	2.30
50	CBT40-FMC38.1-75	P2776148	38.1	75	85	22	15.9	7	M16	2	2.60
	CBT50-FMC25.4-45	P2776149	25.4	45	70	20	9.5	6	M12	1	4.10
	CBT50-FMC25.4-90	P2776150	25.4	90	70	20	9.5	6	M12	1	5.50
	CBT50-FMC25.4-150	P2776151	25.4	150	70	20	9.5	6	M12	1	7.30
	CBT50-FMC38.1-45	P2776152	38.1	45	85	22	15.9	7	M16	1	4.20
	CBT50-FMC38.1-75	P2776153	38.1	75	85	22	15.9	7	M16	1	5.50
	CBT50-FMC38.1-105	P2776154	38.1	105	85	22	15.9	7	M16	1	7.00

- ▶ Through coolant system is optional.
- ▶ For parts, please refer to page 207.

FACE MILL ARBOR

FMC

AUFNAHMEDORN FÜR MESSERKÖPFE
ARBRE PORTE FRAISE A ALESAGE
MANDRINO PORTA FRESE FRONTALE
EJE PARA PLATOS DE PLACAS

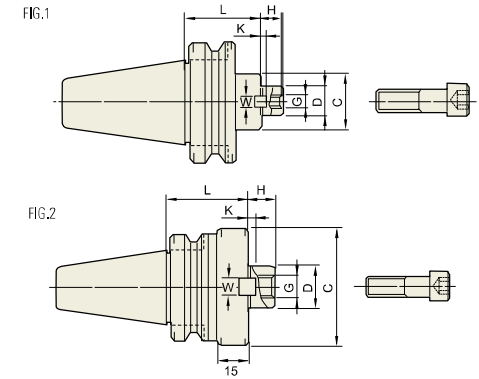

JIS B6339 - BT	Taper Accuracy AT3	G Value 6.3	RPM 15,000	Coolant System A
----------------	-----------------------	----------------	---------------	---------------------

JIS B6339/MAS 403-BT

◆ METRIC TYPE

TAPER No.	MODEL No.	EDP No.	D	L	C	H	W	K	G	FIG.	WEIGHT (Kg)
30	BT30-FMC22-45	P2776101	22	45	45	18	10	5	M10	2	0.80
	BT40-FMC22-45	P2776102	22	45	45	18	10	5	M10	1	1.30
40	BT40-FMC27-60	P2776103	27	60	70	20	12	6	M12	2	1.50
	BT40-FMC32-60	P2776104	32	60	85	22	14	7	M16	2	2.30
50	BT50-FMC22-60	P2776105	22	60	45	18	10	5	M10	1	4.20
	BT50-FMC22-105	P2776106	22	105	45	18	10	5	M10	1	4.70
	BT50-FMC22-150	P2776107	22	150	45	18	10	5	M10	1	5.30
	BT50-FMC27-45	P2776108	27	45	70	20	12	6	M12	1	4.10
	BT50-FMC27-90	P2776109	27	90	70	20	12	6	M12	1	5.50
	BT50-FMC27-150	P2776110	27	150	70	20	12	6	M12	1	7.30
	BT50-FMC32-60	P2776111	32	60	85	22	14	7	M16	1	4.20
	BT50-FMC32-105	P2776112	32	105	85	22	14	7	M16	1	5.50
	BT50-FMC32-150	P2776113	32	150	85	22	14	7	M16	1	7.00

◆ INCH TYPE

TAPER No.	MODEL No.	EDP No.	D	L	C	H	W	K	G	FIG.	WEIGHT (Kg)
30	BT30-FMC25.4-45	P2776114	25.4	45	70	20	9.5	6	M12	2	1.10
	BT40-FMC25.4-60	P2776115	25.4	60	70	20	9.5	6	M12	2	1.50
40	BT40-FMC25.4-90	P2776116	25.4	90	70	20	9.5	6	M12	2	2.20
	BT40-FMC38.1-60	P2776117	38.1	60	85	22	15.9	7	M16	2	2.30
50	BT40-FMC38.1-75	P2776118	38.1	75	85	22	15.9	7	M16	2	2.60
	BT50-FMC25.4-45	P2776119	25.4	45	70	20	9.5	6	M12	1	4.10
	BT50-FMC25.4-90	P2776120	25.4	90	70	20	9.5	6	M12	1	5.50
	BT50-FMC25.4-150	P2776121	25.4	150	70	20	9.5	6	M12	1	7.30
	BT50-FMC38.1-45	P2776122	38.1	45	85	22	15.9	7	M16	1	4.20
	BT50-FMC38.1-75	P2776123	38.1	75	85	22	15.9	7	M16	1	5.50
	BT50-FMC38.1-105	P2776124	38.1	105	85	22	15.9	7	M16	1	7.00

- ▶ Through coolant system is optional.
- ▶ CAT(ANSI B5.50) taper and Inch type products are available.
- ▶ For parts, please refer to page 207.

FACE MILL ARBOR

AUFNAHMEDORN FÜR MESSERKÖPFE
ARBRE PORTE FRAISE À ALÈSAGE
MANDRINO PORTA FRESE FRONTALE
EJE PARA PLATOS DE PLACAS

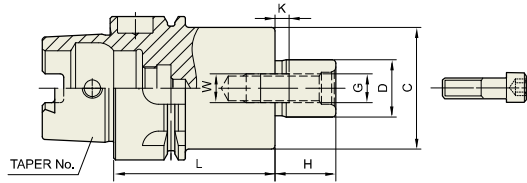

DIN 69893 - HSK	Taper Accuracy -	G Value 6.3	RPM 15,000	Coolant System A
---------------------------	---------------------	----------------	---------------	---------------------

DIN 69893/ISO 12164-1-HSK FORM A

Unit : mm

TAPER No.	MODEL No.	EDP No.	D	C	L	H	W	K	G	WEIGHT (Kg)
40A	HSK40A-FMC16-45	P2774707	16	34	45	17	8	4	M8	0.40
	HSK40A-FMC22-50	P2774708	22	45	50	18	10	5	M10	0.50
	HSK40A-FMC27-60	P2774709	27	68	60	20	12	7	M12	0.70
50A	HSK50A-FMC16-40	P2774710	16	34	40	17	8	4	M8	
	HSK50A-FMC22-50	P2774711	22	45	50	18	10	5	M10	
	HSK50A-FMC27-60	P2774712	27	70	60	20	12	6	M12	
63A	HSK63A-FMC22-45	P2774701	22	45	45	18	10	5	M10	
	HSK63A-FMC27-60	P2774702	27	70	60	20	12	6	M12	
	HSK63A-FMC32-60	P2774703	32	85	60	22	14	7	M16	
100A	HSK100A-FMC22-50	P2774704	22	45	50	18	10	5	M10	
	HSK100A-FMC27-60	P2774705	27	70	60	20	12	6	M12	
	HSK100A-FMC32-60	P2774706	32	85	60	22	14	7	M16	

- ▶ Through coolant system is optional.
- ▶ For parts, please refer to page 207.

FMC

PART

KEY & BOLT (For FACE MILL ARBOR)

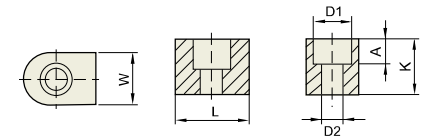

KEY

Unit : mm

KEY	EDP No.	W	K	L	D1	D2	A	APPLICABLE ARBOR
8x7x12.8	P2778857	8	7	12.8	5.8	3.2	3.2	SMA16
10x7.8x15.5	P2778858	10	7.8	15.5	7.5	4.2	4.3	SMA22
9.52x9.52x10.2	P2774753	9.52	9.52	10.2	7.5	4.5	5.2	FMA25.4 / FMB25.4
9.5x12x11	P2774754	9.5	12	11	7.5	4.2	5	FMC25.4
12x9x18.5	P2778859	12	9	18.5	9	5.3	5.5	SMA27
10x10x11	P2774756	10	10	11	7.5	4.2	5	FMC22
14x11.5x20.5	P2778860	14	11.5	20.5	10.5	6.5	6.5	SMA32
12x13x18	P2774758	12	13	18	9	5.3	8	FMB27 / FMC27
16x13.5x23.5	P2778861	16	13.5	23.5	10.5	6.5	6.5	SMA40
12.7x12.7x12.7	P2774760	12.7	12.7	12.7	7.5	4.5	5.2	FMA31.75
15.87x15.87x18.5	P2774761	15.87	15.87	18.5	10.3	6.6	7.5	FMA38.1 / FMB40 / FMB40F
14x15x20	P2774762	14	15	20	10.5	6.3	8	FMC32
18x18x28.5	P2778862	18	18	28.5	10.5	6.5	10	SMA50
19x18x22	P2774764	19	18	22	10.5	6.3	7	FMA50.8

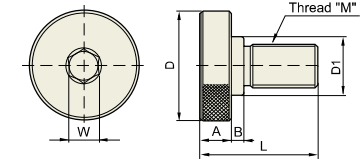

MOUNTING BOLT

Unit : mm

MOUNTING BOLT	EDP No.	M	D	D1	L	A	B	W	APPLICABLE ARBOR
MB8	P2774765	8x1.25	20	15	23	7	2	6	FMC16
MB10	P2774766	10x1.5	28	18	29	9	2	8	FMC22
MB12	P2774767	12x1.75	33	23	32	10	2	10	FMC27 / FMB27 / FMA25.4
MB16	P2774768	16x2.0	40	23	42	10	6	12	FMC32 / FMA31.75
MB20	P2774769	20x2.5	50	27	54	14	6	14	FMC40 / FMA38.1 / FMB40 / FMB40F
MB24	P2774770	24x3.0	65	37	62	14	10	17	FMA50.8