

KORLOY



Außendrehhalter & Bohrstangen



Luft- und Raumfahrt



Automotive



Medizintechnik



Eisenbahn



Drehen

KORLOY Drehwerkzeuge decken den gesamten ISO-Bereich ab. Sie bieten Lösungen für nahezu alle Anwendungsbereiche mit höchsten Ansprüchen an Qualität und Präzision.



INHALT

Außendrehhalter

- 04 Codesystem (ISO)
- 05 Anweisungen zur Montage
- 06 Index
- 09 Merkmale Doppelklemmsystem /
Neues Kniehebelsystem
- 10 Doppelklemmsystem
- 16 Kniehebelsystem
- 26 Keilklemmsystem
- 27 Klemmsystem
- 31 Mehrfachklemmsystem
- 42 Schraubsystem
- 52 Halter für keramische
Wendeschneidplatten

Bohrstangen

- 55 Codesystem (ISO)
- 56 Anweisungen zur Montage
- 57 Index
- 59 Doppelklemmsystem
- 64 Kniehebelsystem
- 67 Klemmsystem
- 69 Mehrfachklemmsystem
- 74 Schraubsystem
- 83 Compact Mini
- 85 Bohrstange mit Hartmetallschaft



Codesystem (ISO) für Außendrehhalter

P S K N R 25 25 - M 12

- 1
Spannsystem
- 2
Wendeschneidplattenform
- 3
Einstellwinkel
- 4
Freiwinkel
- 5
Werkzeugrichtung
- 6
Schafthöhe
- 7
Schaftbreite
- 8
Werkzeuglänge
- 9
Schneidkantenlänge

1 Spannsystem
P S K N R 25 25 - M 12

C D M P S W

2 Wendeschneidplattenform
P S K N R 25 25 - M 12

C D E K

L R S T

V W

3 Einstellwinkel
P S K N R 25 25 - M 12

B D E F G J K

L N R S T V Y

4 Freiwinkel
P S K N R 25 25 - M 12

B C D E

F N P

5 Werkzeugrichtung
P S K N R 25 25 - M 12

L N R

6 Schafthöhe
P S K N R 25 25 - M 12

H

7 Schaftbreite
P S K N R 25 25 - M 12

W

8 Werkzeuglänge
P S K N R 25 25 - M 12

A - 32	H - 100	Q - 180	X-Spezial Artikel
B - 40	J - 110	R - 200	
C - 50	K - 125	S - 250	
D - 60	L - 140	T - 300	
E - 70	M - 150	U - 350	
F - 80	N - 160	V - 400	
G - 90	P - 170	W - 450	

9 Schneidkantenlänge
P S K N R 25 25 - M 12



Montage von Außendrehhaltern

Doppelklemmsystem (D)

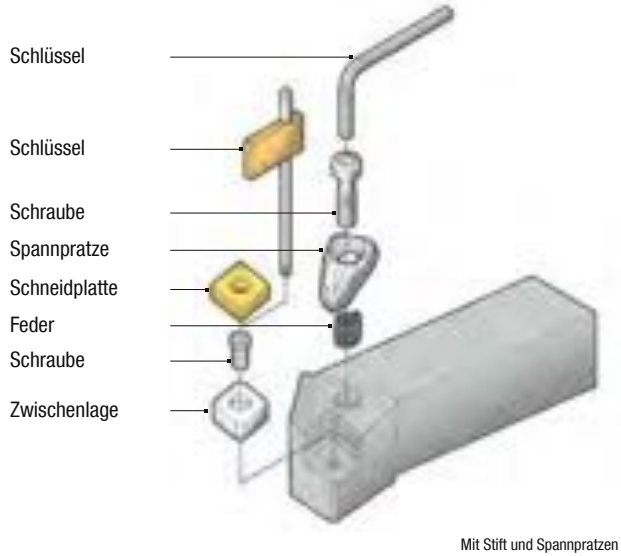

Kniehebelsystem (P)

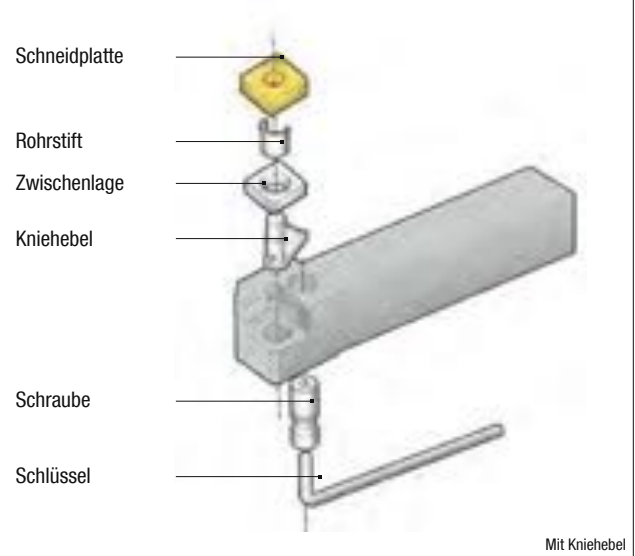

Keilklemmsystem (W)

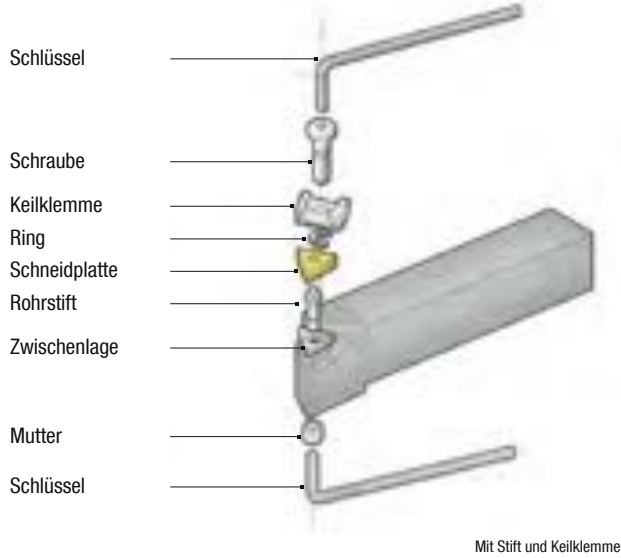

Spannpratzenklemmsystem (C)

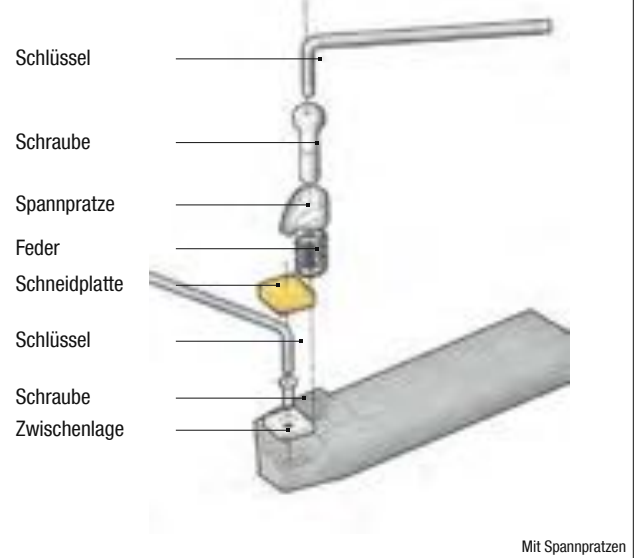

Mehrfachklemmsystem (M)

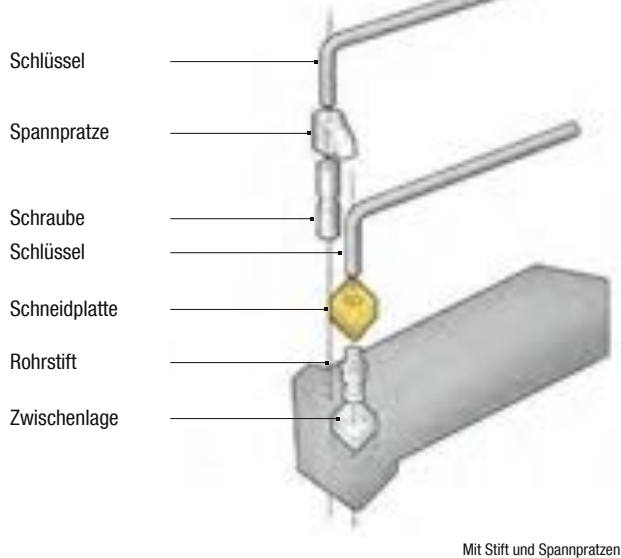

Schraubklemmsystem (S)

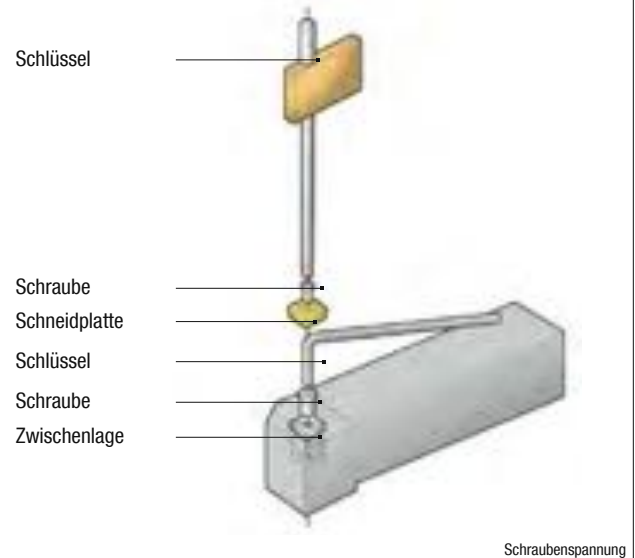



Doppelklemmsystem

Schnittform										
Bezeichnung	DCBNR/L	DCKNR/L	DCLNR/L	DDJNR/L	DSBNR/L	DSDNN	DSKNR/L	DSSNR/L	DTFNR/L	DTGNR/L
Anstellwinkel	75°	75°	95°	93°	75°	45°	75°	45°	90°	90°
Seite	9	9	10	10	11	11	12	12	13	13
Drehen	•		•	•	•	•		•		•
Kopieren				•						
Plandrehen		•	•				•	•	•	
Anfasen										
Rückwärtsdrehen			•	•						

Schnittform										
Bezeichnung	DTJNR/L	DVJNR/L	DVVNN	DWLNR/L						
Anstellwinkel	93°	93°	72,5°	95°						
Seite	13	14	14	14						
Drehen	•	•	•	•						
Kopieren		•	•	•						
Plandrehen				•						
Anfasen										
Rückwärtsdrehen		•		•						

Kniehebelsystem / Neues Kniehebelsystem

Schnittform										
Bezeichnung	PCBNR/L	PCKNR/L	PCLNR/L	PDJNR/L	PDNNR/L	PDNNN	PRDCN	PRGCR/L	PSBNR/L	PSDNN
Anstellwinkel	75°	75°	95°	93°	62,5°		-	-	75°	45°
Seite	15	15	16	17	17	18	18	18	19	20
Drehen	•	•	•	•	•		•	•	•	•
Kopieren				•	•		•	•		
Plandrehen			•							
Anfasen										
Rückwärtsdrehen		•	•							

Schnittform										
Bezeichnung	PSKNR/L	PSSNR/L	PTFNR/L	PTGNR/L	PTTNR/L	PWLNR/L				
Anstellwinkel	75°	45°	90°	90°	60°	95°				
Seite	21	22	22	23	23	24				
Drehen		•		•	•	•				
Kopieren										
Plandrehen	•	•	•			•				
Anfasen					•					
Rückwärtsdrehen						•				



Keilklemmsystem

Schnittform									
Bezeichnung	WTENN	WTJNR/L	WTXNR/L	WWLNR/L					
Anstellwinkel	60°	93°	105°	95°					
Seite	25	25	25	26					
Drehen	•	•	•	•					
Kopieren	•	•	•	•					
Plandrehen									
Anfasen									
Rückwärtsdrehen		•	•	•					

Spannpratzenklemmsystem

Schnittform									
Bezeichnung	CKJNR/L	CKNNR/L	CSDPN	CSKPR/L	CTFPR/L	CTGPR/L			
Anstellwinkel	93°	62,5°	45°	75°	90°	90°			
Seite	27	27	28	28	28	29			
Drehen	•	•	•			•			
Kopieren	•	•							
Plandrehen				•	•				
Anfasen									
Rückwärtsdrehen	•								

Mehrfachklemmsystem

Schnittform										
Bezeichnung	MCKNR/L	MCLNR/L	MCMNN	MCRNR/L	MDJNR/L	MDNNN	MDQNR/L	MSBNR/L	MSDNN	MSKNR/L
Anstellwinkel	75°	95°	50°	75°	93°	62,5°	107,5°	75°	45°	75°
Seite	30	30	31	31	32	32	33	33	34	34
Drehen		•	•	•	•	•	•	•	•	
Kopieren					•	•	•			
Plandrehen	•	•								•
Anfasen										
Rückwärtsdrehen		•			•		•			

Schnittform										
Bezeichnung	MSRRN/L	MSSNR/L	MTENN	MTFNR/L	MTGNR/L	MTJNR/L	MVJNR/L	MVQNR/L	MVVNN	MWLNR/L
Anstellwinkel	75°	45°	60°	90°	90°	93°	93°	117,5°	72,5°	95°
Seite	36	36	37	37	38	38	38	38	39	39
Drehen	•	•	•		•	•	•	•	•	•
Kopieren			•			•	•	•	•	
Plandrehen		•		•		•				•
Anfasen										
Rückwärtsdrehen						•	•	•		•



Schraubklemmsystem

Schnittform										
Bezeichnung	SCACR/L	SCLCR/L	SDACR/L	SDJCR/L	SDNCN	SRDCN	SRGCR/L	SSBCR/L	SSDCN	SSKCR/L
Anstellwinkel	90°	95°	90°	93°	62,5°	-	-	75°	45°	75°
Seite	40	40	41	41	42	42	43	43	44	44
Drehen	•	•	•	•	•	•	•	•	•	
Kopieren			•	•	•	•	•			
Plandrehen		•								•
Anfasen										
Rückwärtsdrehen		•		•						

Schnittform										
Bezeichnung	SSSCR/L	STACR/L	STFCR/L	STGCR/L	STTCR/L	SVABR/L	SVHBR/L	SVJBR/L	SVJCR/L	SVVBN
Anstellwinkel	45°	90°	90°	90°	60°	90°	107,5°	93°	93°	72,5°
Seite	44	45	45	46	46	47	47	48	48	49
Drehen	•	•		•	•	•	•	•	•	•
Kopieren						•	•	•	•	•
Plandrehen	•		•							
Anfasen										
Rückwärtsdrehen						•	•	•	•	

Schnittform										
Bezeichnung	SVVCN	SWACR/L								
Anstellwinkel	72,5°	90°								
Seite	49	50								
Drehen	•	•								
Kopieren	•									
Plandrehen										
Anfasen										
Rückwärtsdrehen										

Halter für keramische Wendeschneidplatten

Schnittform										
Bezeichnung	CCNLR/L	CRDNN	CRGCR/L	CSDNN	CSKNR/L	CTFNR/L	CTGCR/L			
Anstellwinkel	95°	-	-	45°	75°	90°	90°			
Seite	B150	B150	B150	B151	B151	B151	B152			
Drehen	•	•	•	•			•			
Kopieren			•							
Plandrehen	•				•	•				
Anfasen										
Rückwärtsdrehen	•									



Doppelklemmsystem

Stabile Klemmung mit Doppelklemmsystem

Merkmale

- Einfaches und leistungsstarkes Klemmsystem mit nur einer Klemmschraube
- Das leistungsstarke Doppelklemmsystem (oben und innen) eignet sich für den Einsatz unter sehr schweren Zerspanungsbedingungen
- Der Halter zeichnet sich dank der speziellen Konstruktion im hinteren Teil der Klemme durch eine hohe Präzision aus
- Kompaktes und optimiertes Design zur Vermeidung von Störungen durch Späne in Verbindung mit einer leistungsstarken Klemme

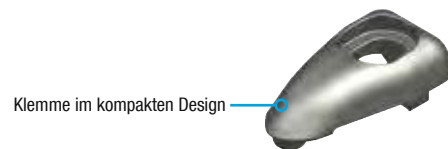
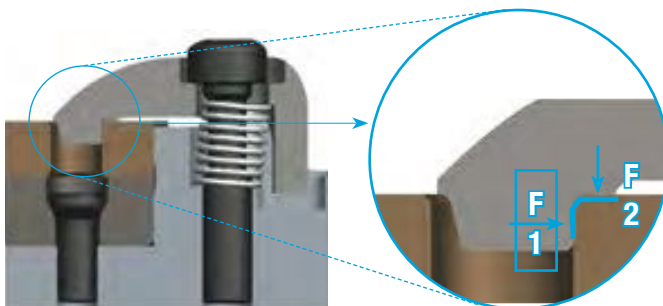
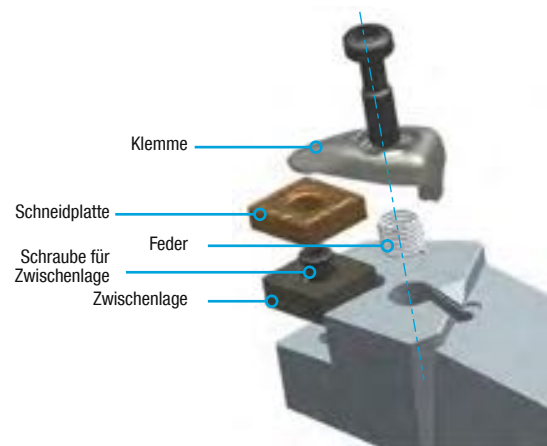

Neues Kniehebelsystem

Verbesserte Haltbarkeit und Spannkraft im Vergleich zu herkömmlichen Kniehebelsystemen

Merkmale

- Der Halter zeichnet sich dank der speziellen Konstruktion des verbesserten Hebelplattensitzes durch eine hohe Präzision aus
- Die Haltbarkeit der Teile wurde verbessert
- Überragende Standzeiten durch das leistungsstarke Klemmsystem und die optimierte Konstruktion
- Entsprechendes Zubehör auf dem Schaft des jeweiligen Halters vermerkt

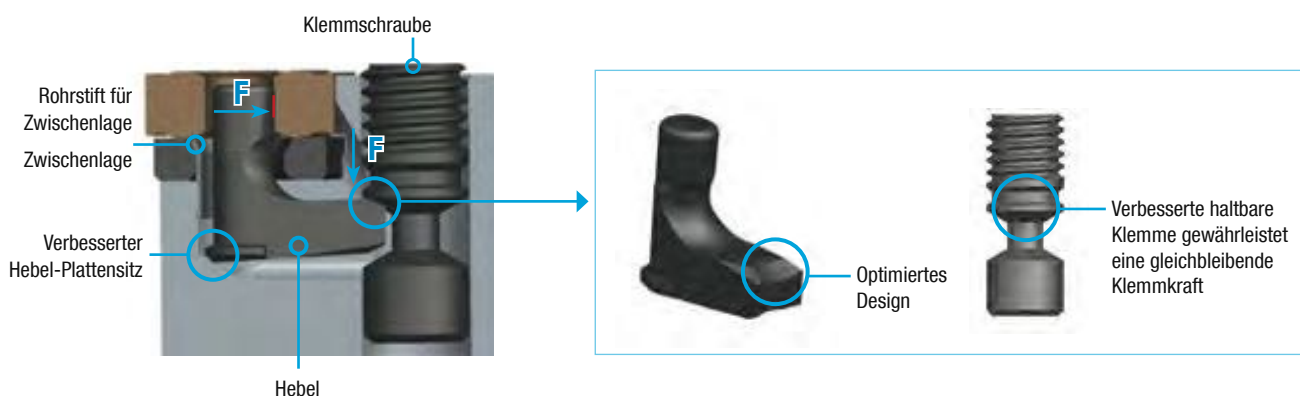



DCBNR/L

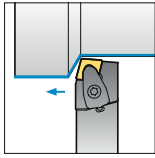

Rechtsausführung
75°

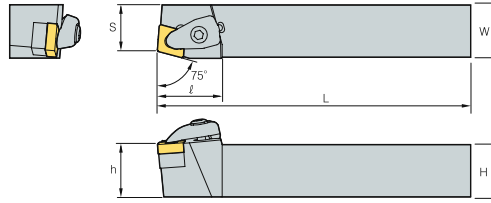

WSP



CN_

(mm)

Bezeichnung	L	R	H	W	L	S	h	ℓ	WSP	Feder	Klemme	Klemmschraube	Lagenschraube	Schlüssel	Zwischenlage	
DCBNR/L	2020-K12	●	●	20	20	125	17	20	31	CN_1204_	SPR0714	CVH4	CHX0518	FTKA0410	HW30P	SC44V
	2525-M12	▲	▲	25	25	150	22	25	31		SPR0714	CVH4	CHX0518	FTKA0410	HW30P	SC44V
	2525-M16	▲	▲	25	25	150	22	25	36	CN_1606_	SPR0811	CVH5	CHX0622	FTNA0511	HW40L	SC54V
	3225-P12	○	●	32	25	170	22	32	31	CN_1204_	SPR0714	CVH4	CHX0518	FTKA0410	HW30P	SC44V
	3232-P16	○	○	32	32	170	27	32	36	CN_1606_	SPR0811	CVH5	CHX0622	FTNA0511	HW40L	SC54V
	3232-P19	▲	▲	32	32	170	27	32	40	CN_1906_	SPR0811	CVH6	CHX0622	FTNA0511	HW40L	SC63V
	4040-S19	▲	▲	40	40	250	35	40	40		SPR0811	CVH6	CHX0622	FTNA0511	HW40L	SC63V
	4040-S25	○	○	40	40	250	35	40	47	CN_2507_	SPR1018	CVH8	CHX0835	FTKA0612	HW50L	SC83V

DCKNR/L

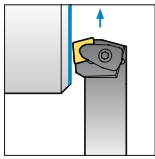

Rechtsausführung
75°

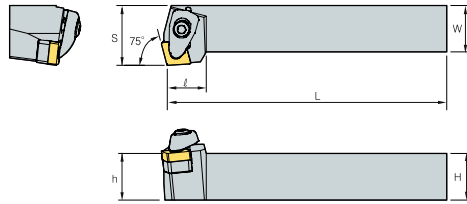

WSP



CN_

(mm)

Bezeichnung	L	R	H	W	L	S	h	ℓ	WSP	Feder	Klemme	Klemmschraube	Lagenschraube	Schlüssel	Zwischenlage	
DCKNR/L	2020-K12	▲	○	20	20	125	25	20	21	CN_1204_	SPR0714	CVH4	CHX0518	FTKA0410	HW30P	SC44V
	2525-M12	▲	▲	25	25	150	32	25	21		SPR0714	CVH4	CHX0518	FTKA0410	HW30P	SC44V
	3225-P12	○	○	32	25	170	32	32	21		SPR0714	CVH4	CHX0518	FTKA0410	HW30P	SC44V
	3232-P16	○	▲	32	32	170	40	32	26	CN_1606_	SPR0811	CVH5	CHX0622	FTNA0511	HW40L	SC54V
	4040-S16	○	○	40	40	250	50	40	26		SPR0811	CVH5	CHX0622	FTNA0511	HW40L	SC54V
	4040-S19	○	○	40	40	250	50	40	26	CN_1906_	SPR0811	CVH6	CHX0622	FTNA0511	HW40L	SC63V



DCLNR/L

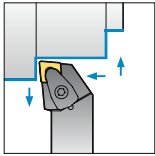

Rechtsausführung
95°

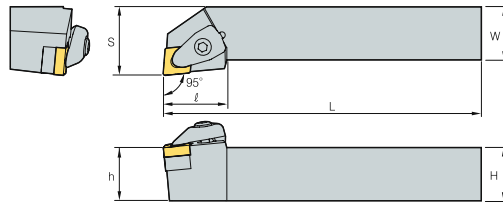

WSP



CN_

(mm)

Bezeichnung	L	R	H	W	L	S	h	ℓ	WSP	Feder	Klemme	Klemmschraube	Legenschraube	Schlüssel	Zwischenlage
DCLNR/L 2020-K09	▲	▲	20	20	125	25	20	24,5	CN_0903_	SPR0510	CVH3	CHX0415	FTKA0307	HW25P	SC32V
2020-K12	▲	▲	20	20	125	25	20	30	CN_1204_	SPR0714	CVH4	CHX0518	FTKA0410	HW30P	SC44V
2525-M09	▲	▲	25	25	150	32	25	24,5	CN_0903_	SPR0510	CVH3	CHX0415	FTKA0307	HW25P	SC32V
2525-M12	▲	▲	25	25	150	32	25	30	CN_1204_	SPR0714	CVH4	CHX0518	FTKA0410	HW30P	SC44V
2525-M16	▲	▲	25	25	150	32	25	36	CN_1606_	SPR0811	CVH5	CHX0622	FTNA0511	HW40L	SC54V
2525-M19	○	▲	25	25	150	32	25	40	CN_1906_	SPR0811	CVH6	CHX0622	FTNA0511	HW40L	SC63V
3225-P12	▲	▲	32	25	170	32	32	30	CN_1204_	SPR0714	CVH4	CHX0518	FTKA0410	HW30P	SC44V
3225-P16	▲	●	32	25	170	32	32	36	CN_1606_	SPR0811	CVH5	CHX0622	FTNA0511	HW40L	SC54V
3225-P19	○	○	32	25	170	32	32	40	CN_1906_	SPR0811	CVH6	CHX0622	FTNA0511	HW40L	SC63V
3232-P12	▲	▲	32	32	170	40	32	30	CN_1204_	SPR0714	CVH4	CHX0518	FTKA0410	HW30P	SC44V
3232-P16	▲	▲	32	32	170	40	32	36	CN_1606_	SPR0811	CVH5	CHX0622	FTNA0511	HW40L	SC54V
3232-P19	▲	▲	32	32	170	40	32	40	CN_1906_	SPR0811	CVH6	CHX0622	FTNA0511	HW40L	SC63V
4040-S19	▲	▲	40	40	250	50	40	40	CN_2507_	SPR0811	CVH6	CHX0622	FTNA0511	HW40L	SC63V
4040-S25	○	○	40	40	250	50	40	47		SPR1018	CVH8	CHX0835	FTKA0612	HW50L	SC83V
5050-T25	○	○	50	50	300	60	50	47		SPR1018	CVH8	CHX0835	FTKA0612	HW50L	SC83V

DDJNR/L

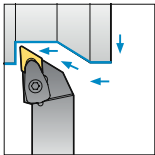

Rechtsausführung
93°

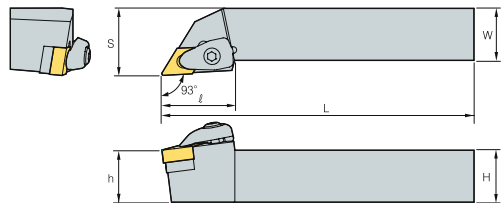

WSP



DN_

(mm)

Bezeichnung	L	R	H	W	L	S	h	ℓ	WSP	Feder	Klemme	Klemmschraube	Legenschraube	Schlüssel	Zwischenlage
DDJNR/L 2020-K11	▲	▲	20	20	125	25	20	30	DN_1104_	SPR0510	CVH3	CHX0415	FTKA0307	HW25P	SD32V
2020-K15	▲	▲	20	20	125	25	20	35	DN_1506_	SPR0714	CVH4	CHX0518	FTKA0410	HW30P	SD43V
2020-K15-3	▲	▲	20	20	125	25	20	35	DN_1504_	SPR0714	CVH4	CHX0518	FTKA0410	HW30P	SD44V
2525-M11	▲	▲	25	25	150	32	25	30	DN_1104_	SPR0510	CVH3	CHX0415	FTKA0307	HW25P	SD32V
2525-M15	▲	▲	25	25	150	32	25	35	DN_1506_	SPR0714	CVH4	CHX0518	FTKA0410	HW30P	SD43V
2525-M15-3	▲	▲	25	25	150	32	25	35	DN_1504_	SPR0714	CVH4	CHX0518	FTKA0410	HW30P	SD44V
3225-M15	○		32	25	150	32	32	35	DN_1506_	SPR0714	CVH4	CHX0518	FTKA0410	HW30P	SD43V
3225-P11	○	○	32	25	170	32	32	30	DN_1104_	SPR0510	CVH3	CHX0415	FTKA0307	HW25P	SD32V
3225-P15	▲	▲	32	25	170	32	32	35	DN_1506_	SPR0714	CVH4	CHX0518	FTKA0410	HW30P	SD43V
3232-M15		○	32	32	150	40	32	35	DN_1504_	SPR0714	CVH4	CHX0518	FTKA0410	HW30P	SD43V
3232-P11	○	▲	32	32	170	40	32	30	DN_1104_	SPR0510	CVH3	CHX0415	FTKA0307	HW25P	SD32V
3232-P15	▲	▲	32	32	170	40	32	35	DN_1506_	SPR0714	CVH4	CHX0518	FTKA0410	HW30P	SD43V
3232-P15-3	○	●	32	32	170	40	32	35	DN_1504_	SPR0714	CVH4	CHX0518	FTKA0410	HW30P	SD44V
4040-S15	▲	▲	40	40	250	50	40	35	DN_1506_	SPR0714	CVH4	CHX0518	FTKA0410	HW30P	SD43V



DSBNR/L

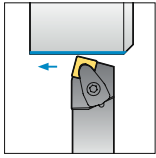

Rechtsausführung
75°

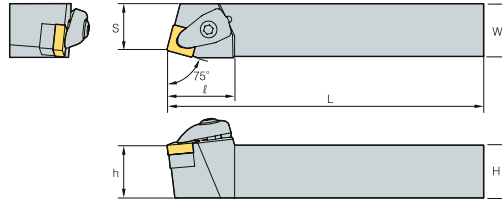

WSP



SN_

(mm)

Bezeichnung	L	R	H	W	L	S	h	ℓ	WSP	Feder	Klemme	Klemmschraube	Lagerschraube	Schlüssel	Zwischenlage
DSBNR/L 2020-K09	○	○	20	20	125	17	20	25	SN_0903_	SPR0510	CVH3	CHX0415	FTKA0307	HW25P	SS32V
	●	▲	20	20	125	17	20	32	SN_1204_	SPR0714	CVH4	CHX0518	FTKA0410	HW30P	SS44V
2020-K12	○	○	25	25	150	22	25	25	SN_0903_	SPR0510	CVH3	CHX0415	FTKA0307	HW25P	SS32V
2525-M09	▲	▲	25	25	150	22	25	32	SN_1204_	SPR0714	CVH4	CHX0518	FTKA0410	HW30P	SS44V
2525-M15	▲	▲	25	25	150	22	25	38	SN_1506_	SPR0811	CVH5	CHX0622	FTKA0511	HW40L	SS54V
3225-P12	●	●	32	25	170	22	32	32	SN_1204_	SPR0714	CVH4	CHX0518	FTKA0410	HW30P	SS44V
3225-P15	○	○	32	25	170	22	32	38	SN_1506_	SPR0811	CVH5	CHX0622	FTKA0511	HW40L	SS54V
3232-P12	▲	○	32	32	170	27	32	32	SN_1204_	SPR0714	CVH4	CHX0518	FTKA0410	HW30P	SS44V
3232-P15	▲	○	32	32	170	27	32	38	SN_1506_	SPR0811	CVH5	CHX0622	FTKA0511	HW40L	SS54V
3232-P19	▲	▲	32	32	170	27	32	43	SN_1906_	SPR0811	CVH6	CHX0622	FTNA0511	HW40L	SS64V
4040-S19	○	○	40	40	250	35	40	43		SPR0811	CVH6	CHX0622	FTNA0511	HW40L	SS64V
4040-S25	○	○	40	40	250	35	40	50	SN_2507_	SPR1018	CVH8	CHX0835	FTKA0612	HW50L	SS84V

KORLOY

DSDNN

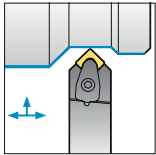

45°

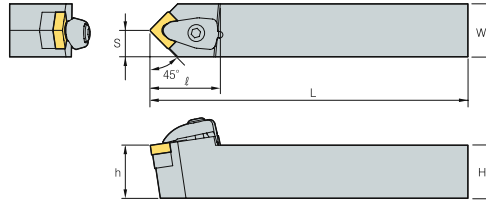

WSP



SN_

(mm)

Bezeichnung	N	H	W	L	S	h	ℓ	WSP	Feder	Klemme	Klemmschraube	Lagerschraube	Schlüssel	Zwischenlage
DSDNN 2020-K09	▲	20	20	125	10	20	26,5	SN_0903_	SPR0510	CVH3	CHX0415	FTKA0307	HW25P	SS32V
	▲	20	20	125	10	20	33	SN_1204_	SPR0714	CVH4	CHX0518	FTKA0410	HW30P	SS44V
2525-M12	▲	25	25	150	12,5	25	33		SPR0714	CVH4	CHX0518	FTKA0410	HW30P	SS44V
2525-M15	▲	25	25	150	12,5	25	39,4	SN_1506_	SPR0811	CVH5	CHX0622	FTKA0511	HW40L	SS54V
3225-P12	▲	32	25	170	12,5	32	33	SN_1204_	SPR0714	CVH4	CHX0518	FTKA0410	HW30P	SS44V
3232-P12	▲	32	32	170	16	32	33		SPR0714	CVH4	CHX0518	FTKA0410	HW30P	SS44V
3232-P15	○	32	32	170	16	32	38	SN_1506_	SPR0811	CVH5	CHX0622	FTKA0511	HW40L	SS54V
3232-P19	▲	32	32	170	16	32	43	SN_1906_	SPR0811	CVH6	CHX0622	FTNA0511	HW40L	SS64V
4040-S19	▲	40	40	250	20	40	45		SPR0811	CVH6	CHX0622	FTNA0511	HW40L	SS64V



DSKNR/L

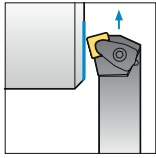

Rechtsausführung
75°

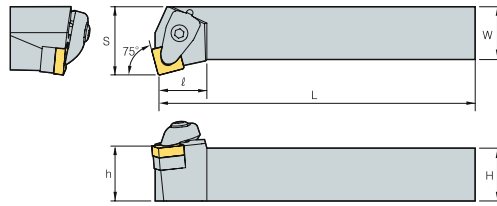

WSP



SN_

(mm)

Bezeichnung	L	R	H	W	L	S	h	ℓ	WSP	Feder	Klemme	Klemmschraube	Lagenschraube	Schlüssel	Zwischenlage
DSKNR/L 2020-K09	○	○	20	20	125	25	20	20	SN_0903_	SPR0510	CVH3	CHX0415	FTKA0307	HW25P	SS32V
2020-K12	●	▲	20	20	125	25	20	23	SN_1204_	SPR0714	CVH4	CHX0518	FTKA0410	HW30P	SS44V
2525-M12	▲	●	25	25	150	32	25	23		SPR0714	CVH4	CHX0518	FTKA0410	HW30P	SS44V
3232-P12	○	●	32	32	170	40	32	23		SPR0714	CVH4	CHX0518	FTKA0410	HW30P	SS44V
3232-P15	▲	○	32	32	170	40	32	28	SN_1506_	SPR0811	CVH5	CHX0622	FTNA0511	HW40L	SS54V
3232-P19	○	○	32	32	170	40	32	35		SPR0811	CVH6	CHX0622	FTNA0511	HW40L	SS64V
4040-S19	▲	○	40	40	250	50	40	43	SN_1906_	SPR0811	CVH6	CHX0622	FTNA0511	HW40L	SS64V

DSSNR/L

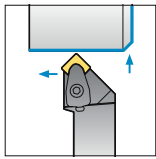

Rechtsausführung
45°

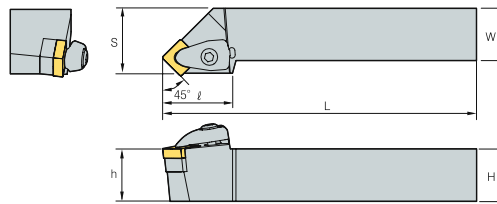

WSP



SN_

(mm)

Bezeichnung	L	R	H	W	L	S	h	ℓ	WSP	Feder	Klemme	Klemmschraube	Lagenschraube	Schlüssel	Zwischenlage
DSSNR/L 2020-K09	○	▲	20	20	125	25	20	28,5	SN_0903_	SPR0510	CVH3	CHX0415	FTKA0307	HW25P	SS32V
2020-K12	▲	▲	20	20	125	25	20	35	SN_1204_	SPR0714	CVH4	CHX0518	FTKA0410	HW30P	SS44V
2525-M12	▲	▲	25	25	150	32	25	35		SPR0714	CVH4	CHX0518	FTKA0410	HW30P	SS44V
2525-M15	○	▲	25	25	150	32	25	38,5	SN_1506_	SPR0811	CVH5	CHX0622	FTKA0511	HW40L	SS54V
3225-P12	○	●	32	25	170	32	32	35	SN_1204_	SPR0714	CVH4	CHX0518	FTKA0410	HW30P	SS44V
3232-P12	▲	▲	32	32	170	40	32	35		SPR0714	CVH4	CHX0518	FTKA0410	HW30P	SS44V
3232-P15	▲	▲	32	32	170	40	32	38,5	SN_1506_	SPR0811	CVH5	CHX0622	FTKA0511	HW40L	SS54V
3232-P19	▲	▲	32	32	170	40	32	46	SN_1906_	SPR0811	CVH6	CHX0622	FTNA0511	HW40L	SS64V
4040-S19	▲	▲	40	40	250	50	40	46		SPR0811	CVH6	CHX0622	FTNA0511	HW40L	SS64V



DTFNR/L

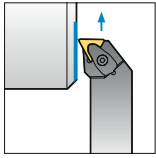

90°

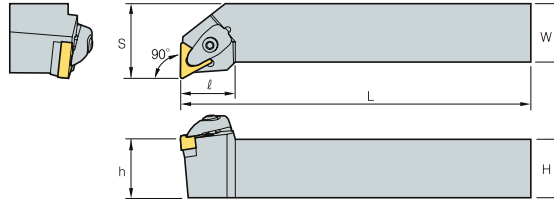

WSP



TN_

(mm)

Bezeichnung	L	R	H	W	L	S	h	ℓ	WSP	Feder	Klemme	Klemmschraube	Lagenschraube	Schlüssel	Zwischenlage	
DTFNR/L	2020-K16	▲	▲	20	20	125	25	20	24,5	TN_1604_	SPR0510	CVH3	CHX0415	FTKA0307	HW25P	ST32V
	2525-M16	▲	▲	25	25	150	32	25	24,5		SPR0510	CVH3	CHX0415	FTKA0307	HW25P	ST32V
	2525-M22	○	○	25	25	150	32	25	33	TN_2204_	SPR0714	CVH4	CHX0518	FTKA0410	HW30P	ST44V
	3225-P22	○	○	32	25	170	32	32	33		SPR0714	CVH4	CHX0518	FTKA0410	HW30P	ST44V
	3232-P16	▲	▲	32	32	170	40	32	23,5	TN_1604_	SPR0510	CVH3	CHX0415	FTKA0307	HW25P	ST32V
	3232-P22	▲	▲	32	32	170	40	32	33,5	TN_2204_	SPR0714	CVH4	CHX0518	FTKA0410	HW30P	ST44V

DTGNR/L

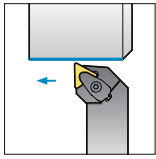

90°

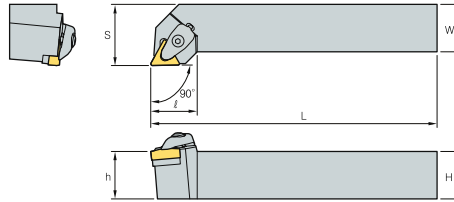

WSP



TN_

(mm)

Bezeichnung	L	R	H	W	L	S	h	ℓ	WSP	Feder	Klemme	Klemmschraube	Lagenschraube	Schlüssel	Zwischenlage	
DTGNR/L	2020-K16	○	▲	20	20	125	25	20	24,5	TN_1604_	SPR0510	CVH3	CHX0415	FTKA0307	HW25P	ST32V
	2525-M16	○	▲	25	25	150	32	25	24,5		SPR0510	CVH3	CHX0415	FTKA0307	HW25P	ST32V
	2525-M22	○	▲	25	25	150	32	25	32,6	TN_2204_	SPR0714	CVH4	CHX0518	FTKA0410	HW30P	ST44V
	3225-P22	○	○	32	25	170	32	32	32,6		SPR0714	CVH4	CHX0518	FTKA0410	HW30P	ST44V
	3232-P16	○	▲	32	32	170	40	32	24,5	TN_1604_	SPR0510	CVH3	CHX0415	FTKA0307	HW25P	ST32V
	3232-P22	○	▲	32	32	170	40	32	32,6	TN_2204_	SPR0714	CVH4	CHX0518	FTKA0410	HW30P	ST44V

DTJNR/L

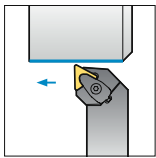

93°

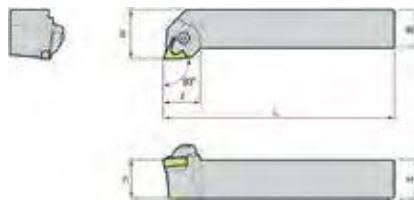

WSP



TN_

(mm)

Bezeichnung	L	R	H	W	L	S	h	ℓ	WSP	Feder	Klemme	Klemmschraube	Lagenschraube	Schlüssel	Zwischenlage	
DTJNR/L	2020-K16	▲	▲	20	20	125	25	20	24,5	TN_1604_	SPR0510	CVH3	CHX0415	FTKA0307	HW25P	ST32V
	2525-M16	○	▲	25	25	150	32	25	24,5		SPR0510	CVH3	CHX0415	FTKA0307	HW25P	ST32V
	2525-M22	○	▲	25	25	150	32	25	32,6	TN_2204_	SPR0714	CVH4	CHX0518	FTKA0410	HW30P	ST44V
	3232-P16	○	○	32	32	170	40	32	24,5	TN_1604_	SPR0510	CVH3	CHX0415	FTKA0307	HW25P	ST32V
	3232-P22	▲	○	32	32	170	40	32	32,6	TN_2204_	SPR0714	CVH4	CHX0518	FTKA0410	HW30P	ST44V



DVJNR/L

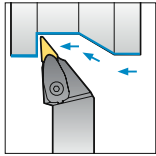

93°

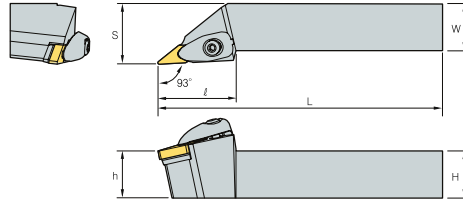

WSP



VN_

Bezeichnung	L	R	H	W	L	S	h	ℓ	WSP	Feder	Klemme	Klemmschraube	LAGenschraube	Schlüssel	Zwischenlage
DVJNR/L 2020-K16	▲	▲	20	20	125	25	20	41,5	VN_1604_	SPR0714	CVH3V	CHX0518	FTNA03508	HW30P	SV32V
2525-M16	▲	▲	25	25	150	32	25	41,5		SPR0714	CVH3V	CHX0518	FTNA03508	HW30P	SV32V
3232-P16	▲	▲	32	32	170	40	32	41,5		SPR0714	CVH3V	CHX0518	FTNA03508	HW30P	SV32V

(mm)

DVNN

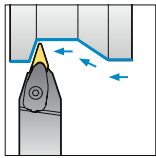

72,5°

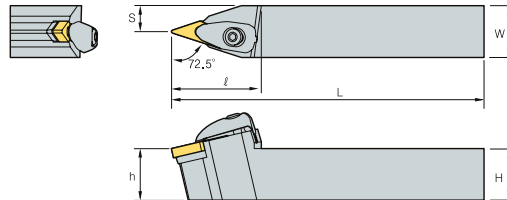

WSP



VN_

Bezeichnung	N	H	W	L	S	h	ℓ	WSP	Feder	Klemme	Klemmschraube	LAGenschraube	Schlüssel	Zwischenlage
DVNN 2020-K16	▲	20	20	125	10	20	40	VN_1604_	SPR0714	CVH3V	CHX0518	FTNA03508	HW30P	SV32V
2525-M16	▲	25	25	150	12,5	25	40		SPR0714	CVH3V	CHX0518	FTNA03508	HW30P	SV32V
3232-P16	▲	32	32	170	16	32	40		SPR0714	CVH3V	CHX0518	FTNA03508	HW30P	SV32V

(mm)

DWLNR/L

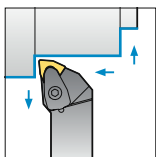

95°

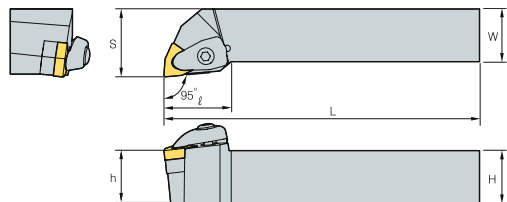

WSP



WN_

Bezeichnung	L	R	H	W	L	S	h	ℓ	WSP	Feder	Klemme	Klemmschraube	LAGenschraube	Schlüssel	Zwischenlage
DWLNR/L 2020-K06	▲	▲	20	20	125	25	20	26	WN_T0604_	SPR0510	CVH3	CHX0415	FTKA0307	HW25P	SW32V
2020-K08	▲	▲	20	20	125	25	20	32	WN_0804_	SPR0714	CVH4	CHX0518	FTKA0410	HW30P	SW44V
2525-M06	▲	▲	25	25	150	32	25	26	WN_T0604_	SPR0510	CVH3	CHX0415	FTKA0307	HW25P	SW32V
2525-M08	▲	▲	25	25	150	32	25	32	WN_0804_	SPR0714	CVH4	CHX0518	FTKA0410	HW30P	SW44V

(mm)



PCBNR/L

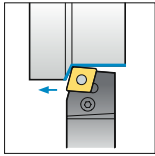

75°

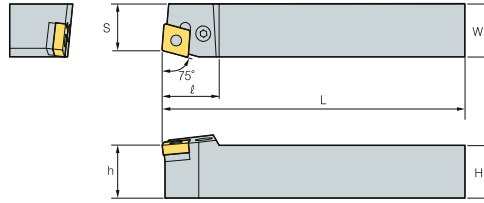

WSP



CN_

(mm)

Bezeichnung	L	R	H	W	L	S	h	ℓ	WSP	Kniehebel	Rohrstift	Rohrstift-Dorn	Schlüssel	Schraube	Zwischenlage	
PCBNR/L	2020-K09-4N	●	●	20	20	125	17	20	27	CN_0903_	LV4	SP4	LSPS8	HW30L	VHX0821	SC42
	2020-K12	▲	▲	20	20	125	17	20	27	CN_1204_	LV4	SP4	LSPS8	HW30L	VHX0821	SC42
	2020-K12N	●	●	20	20	125	17	20	27		LV4N	SP4N	LSPS4	HW30L	VHX0820N	SC42N
	2525-M09-4N	●	●	20	20	125	17	20	27	CN_0903_	LV4N	SP4N	LSPS4	HW30L	VHX0820N	SC42N
	2525-M12	▲	▲	25	25	150	22	25	27	CN_1204_	LV4	SP4	LSPS8	HW30L	VHX0821	SC42
	2525-M12N	●	●	25	25	150	22	25	27		LV4N	SP4N	LSPS4	HW30L	VHX0820N	SC42N
	2525-M16	▲	▲	25	25	150	22	25	33	CN_1606_	LV5	SP5	LSPS6	HW30L	VHX0825	SC53
	2525-M16N	●	●	25	25	150	22	25	33		LV5N	SP5N	LSPS5	HW30L	VHX0820AN	SC53N
	2525-M19	○	○	25	25	150	22	25		CN_1906_	LV6N	SP6N	LSPS6	HW40L	VHX1027N	SC63N
	3225-P12	▲	●	32	25	170	22	32	27	CN_1204_	LV4	SP4	LSPS8	HW30L	VHX0821	SC42
	3225-P12N	●	●	32	25	170	22	32	27		LV4N	SP4N	LSPS4	HW30L	VHX0820N	SC42N
	3232-P16	▲	▲	32	32	170	27	32	33	CN_1606_	LV5	SP5	LSPS6	HW30L	VHX0825	SC53
	3232-P16N	●	●	32	32	170	27	32	33		LV5N	SP5N	LSPS5	HW30L	VHX0820AN	SC53N
	3232-P19	▲	▲	32	32	170	27	32	36	CN_1906_	LV6N	SP6N	LSPS6	HW40L	VHX1027N	SC63N
	3232-P19N	●	●	32	32	170	27	32	36		LV6N	SP6N	LSPS6	HW40L	VHX1027N	SC63N
	3232-T19	○		32	32	300	27	32	36		LV6N	SP6N	LSPS6	HW40L	VHX1027N	SC63N
	4040-S19	▲	▲	40	40	250	35	40	36		LV6N	SP6N	LSPS6	HW40L	VHX1027N	SC63N
	4040-S19N	●	●	40	40	250	35	40	36		LV6N	SP6N	LSPS6	HW40L	VHX1027N	SC63N
	4040-S25	▲	▲	40	40	250	35	40	47	CN_2509_	LV8N	SP8N	LSPS8	HW50L	VHX1236N	SC84N
	4040-S25-5	●	○	40	40	250	35	40	47	CN_2507_	LV8N	SP8N	LSPS8	HW50L	VHX1236N	SC84N
4040-S25-5N	○		40	40	250	35	40	47		LV8N	SP8N	LSPS8	HW50L	VHX1236N	SC84N	
4040-S25N	○	○	40	40	250	35	40	47	CN_2509_	LV8N	SP8N	LSPS8	HW50L	VHX1236N	SC84N	
5050-T250	●		50	50	300	47	50	50		LV8N	SP8N	LSPS8	HW50L	VHX1236N	SC84N	

PCKNR/L

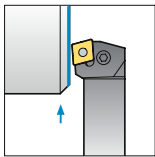

75°

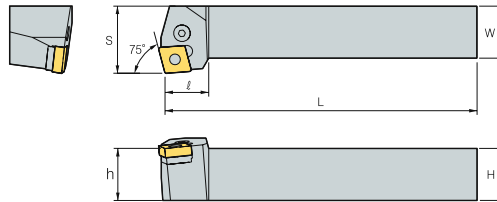

WSP



CN_

(mm)

Bezeichnung	L	R	H	W	L	S	h	ℓ	WSP	Kniehebel	Rohrstift	Rohrstift-Dorn	Schlüssel	Schraube	Zwischenlage	
PCKNR/L	2020-K12	▲	▲	20	20	125	25	20	27	CN_1204_	LV4	SP4	LSPS4	HW30L	VHX0821	SC42
	2020-K12N	●	●	20	20	125	25	20	27		LV4N	SP4N	LSPS4	HW30L	VHX0820N	SC42N
	2525-M12	▲	▲	25	25	150	32	25	27		LV4	SP4	LSPS4	HW30L	VHX0821	SC42
	2525-M12N	●	●	25	25	150	32	25	27		LV4N	SP4N	LSPS4	HW30L	VHX0820N	SC42N
	3225-P12	○	○	32	25	170	40	32	30		LV4	SP4	LSPS4	HW30L	VHX0821	SC42
	3225-P12N	○	○	32	25	170	40	32	30		LV4N	SP4N	LSPS4	HW30L	VHX0820N	SC42N
	3232-P16	○	▲	32	32	170	40	32	26	CN_1606_	LV5	SP5	LSPS5	HW30L	VHX0825	SC53
	3232-P16N		○	32	32	170	40	32	26		LV5N	SP5N	LSPS5	HW30L	VHX0820AN	SC53N
	4040-S16	○	○	40	40	250	50	40	25		LV5	SP5	LSPS5	HW30L	VHX0825	SC53
	4040-S16N		○	40	40	250	50	40	25		LV5N	SP5N	LSPS5	HW30L	VHX0820AN	SC53N



PCLNR/L

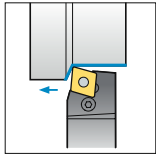

95°

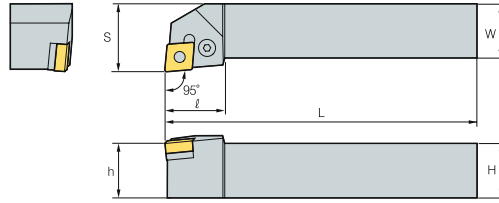

WSP



CN_

(mm)

Bezeichnung	L	R	H	W	L	S	h	l	WSP	Kniehebel	Rohrstift	Rohrstift-Dorn	Schlüssel	Schraube	Zwischenlage
PCLNR/L 1616-H09	▲	▲	16	16	100	20	16	20	CN_0903_	LV3	SP3	LSPS3	HW25L	VHX0617	SC32
1616-H09-4N	●	●	16	16	100	20	16	20	CN_0904_	LV3N	SP3N	LSPS3	HW25L	VHX0617N	SC32N
1616-H09N	○	●	16	16	100	20	16	20	CN_0903_	LV3N	SP3N	LSPS3	HW25L	VHX0617N	SC32N
1616-H12	▲	▲	16	16	100	20	16	28	CN_1204_	LV4	SP4	LSPS4	HW30L	VHX0821	SC42
1616-H12N	●	▲	16	16	100	20	16	28		LV4N	SP4N	LSPS4	HW30L	VHX0817N	SC42N
2020-K09	▲	▲	20	20	125	25	20	22	CN_0903_	LV3	SP3	LSPS3	HW25L	VHX0617	SC32
2020-K09-4N	●	●	20	20	125	25	20	22	CN_0904_	LV3N	SP3N	LSPS3	HW25L	VHX0617N	SC32N
2020-K09N	●	●	20	20	125	25	20	22	CN_0903_	LV3N	SP3N	LSPS3	HW25L	VHX0617N	SC32N
2020-K12	▲	▲	20	20	125	25	20	28	CN_1204_	LV4	SP4	LSPS4	HW30L	VHX0821	SC42
2020-K12N	●	▲	20	20	125	25	20	28		LV4N	SP4N	LSPS4	HW30L	VHX0820N	SC42N
2525-M09	▲	▲	25	25	150	32	25	22	CN_0903_	LV3	SP3	LSPS3	HW25L	VHX0617	SC32
2525-K09-4N	●	●	25	25	150	32	25	22	CN_0904_	LV3N	SP3N	LSPS3	HW25L	VHX0617N	SC32N
2525-M09N	●	●	25	25	150	32	25	22	CN_0903_	LV3N	SP3N	LSPS3	HW25L	VHX0617N	SC32N
2525-M12	▲	▲	25	25	150	32	25	28	CN_1204_	LV4	SP4	LSPS4	HW30L	VHX0821	SC42
2525-M12N	▲	▲	25	25	150	32	25	28		LV4N	SP4N	LSPS4	HW30L	VHX0820N	SC42N
2525-M16	▲	▲	25	25	150	32	25	33	CN_1606_	LV5	SP5	LSPS5	HW30L	VHX0825	SC53
2525-M16N	●	●	25	25	150	32	25	33		LV5N	SP5N	LSPS5	HW30L	VHX0820AN	SC53N
2525-M19	▲	▲	25	25	150	32	25	36	CN_1906_	LV6N	SP6N	LSPS6	HW40L	VHX1027N	SC63N
2525-M19N	●	●	25	25	150	32	25	36		LV6N	SP6N	LSPS6	HW40L	VHX1027N	SC63N
3225-P12	▲	▲	32	25	170	32	32	28	CN_1204_	LV4	SP4	LSPS4	HW30L	VHX0821	SC42
3225-P12N	●	●	32	25	170	32	32	28		LV4N	SP4N	LSPS4	HW30L	VHX0820N	SC42N
3225-P19	▲	▲	32	25	170	32	32	36	CN_1906_	LV6N	SP6N	LSPS6	HW40L	VHX1027N	SC63N
3225-P19N	○	○	32	25	170	32	32	36		LV6N	SP6N	LSPS6	HW40L	VHX1027N	SC63N
3232-P12	▲	▲	32	32	170	40	32	28	CN_1204_	LV4	SP4	LSPS4	HW30L	VHX0821	SC42
3232-P12N	○	●	32	32	170	40	32	28		LV4N	SP4N	LSPS4	HW30L	VHX0820N	SC42N
3232-P16	▲	▲	32	32	170	40	32	33	CN_1606_	LV5	SP5	LSPS5	HW30L	VHX0825	SC53
3232-P16N	●	●	32	32	170	40	32	33		LV5N	SP5N	LSPS5	HW30L	VHX0820AN	SC53N
3232-P19	▲	▲	32	32	170	40	32	36	CN_1906_	LV6N	SP6N	LSPS6	HW40L	VHX1027N	SC63N
3232-P19N	○	○	32	32	170	40	32	36		LV6N	SP6N	LSPS6	HW40L	VHX1027N	SC63N
4040-P19	▲	▲	40	40	170	50	40	36		LV6N	SP6N	LSPS6	HW40L	VHX1027N	SC63N
4040-P19N	○	○	40	40	170	50	40	36		LV6N	SP6N	LSPS6	HW40L	VHX1027N	SC63N
4040-S19	▲	▲	40	40	250	50	40	36		LV6N	SP6N	LSPS6	HW40L	VHX1027N	SC63N
4040-S19N	●	●	40	40	250	50	40	36		LV6N	SP6N	LSPS6	HW40L	VHX1027N	SC63N
4040-S25	▲	▲	40	40	250	50	40	47	CN_2509_	LV8N	SP8N	LSPS8	HW50L	VHX1236N	SC84N
4040-S25-5	●	●	40	40	250	50	40	47	CN_2507_	LV8N	SP8N	LSPS8	HW50L	VHX1236N	SC84N
4040-S25-5N	○	○	40	40	250	50	40	47		LV8N	SP8N	LSPS8	HW50L	VHX1236N	SC84N
4040-S25N	○	○	40	40	250	50	40	47	CN_2509_	LV8N	SP8N	LSPS8	HW50L	VHX1236N	SC84N
5050-S25-5	○	○	50	50	300	60	50	47	CN_2507_	LV8N	SP8N	LSPS8	HW50L	VHX1236N	SC84N
5050-T25	▲	▲	50	50	300	60	50	47	CN_2509_	LV8N	SP8N	LSPS8	HW50L	VHX1236N	SC84N
5050-T25-5	●	●	50	50	300	60	50	47	CN_2507_	LV8N	SP8N	LSPS8	HW50L	VHX1236N	SC84N
5050-T25-5N	○	○	50	50	300	60	50	47		LV8N	SP8N	LSPS8	HW50L	VHX1236N	SC84N
5050-T25N	○	○	50	50	300	60	50	47	CN_2509_	LV8N	SP8N	LSPS8	HW50L	VHX1236N	SC84N



PDJNR/L

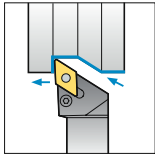

93°

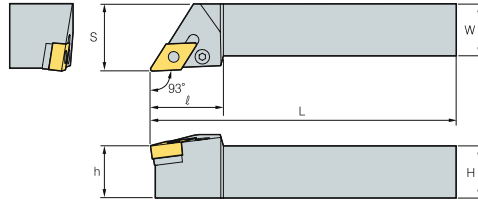

WSP



DN_

(mm)

Bezeichnung	L	R	H	W	L	S	h	ℓ	WSP	Kniehebel	Rohrstift	Rohrstift-Dorn	Schlüssel	Schraube	Zwischenlage
PDJNR/L 1616-H11	▲	▲	16	16	100	20	16	25	DN_1104_	LV3	SP3	LSPS3	HW25L	VHX0617	SD317
1616-H11N	●	●	16	16	100	20	16	25		LV3AN	SP3N-1	LSPS3	HW25L	VHX0617N	SD32N
2020-K11	▲	▲	20	20	125	25	20	25	DN_1105_	LV3	SP3	LSPS3	HW25L	VHX0617	SD317
2020-K11-5N	●	●	20	20	125	25	20	25	DN_1104_	LV3AN	SP3N-1	LSPS3	HW25L	VHX0617N	SD32N
2020-K11N	▲	▲	20	20	125	25	20	25	DN_1506_	LV4B	SP4	LSPS4	HW30L	VHX0821	SD42
2020-K15	▲	▲	20	20	125	25	20	35		LV4BN	SP4N	LSPS4	HW30L	VHX0821N	SD42N
2020-K15N	●	●	20	20	125	25	20	35	DN_1504_	LV4B	SP4	LSPS4	HW30L	VHX0821	SD42
2020-K15-3	○	●	20	20	125	25	20	35		LV4BN	SP4N	LSPS4	HW30L	VHX0821N	SD43N
2020-K15-3N	○	●	20	20	125	25	20	35	DN_1104_	LV3	SP3	LSPS3	HW25L	VHX0617	SD317
2525-M11	▲	▲	25	25	150	32	25	30		LV3	SP3	LSPS3	HW25L	VHX0617	SD317
2525-M11-5N	●	●	25	25	150	32	25	30		LV3	SP3	LSPS3	HW25L	VHX0617	SD317
2525-M11N	●	●	25	25	150	32	25	30	DN_1506_	LV3AN	SP3N-1	LSPS3	HW25L	VHX0617N	SD32N
2525-M15	▲	▲	25	25	150	32	25	35	DN_1506_	LV4B	SP4	LSPS4	HW30L	VHX0821	SD42
2525-M15N	▲	▲	25	25	150	32	25	35		LV4BN	SP4N	LSPS4	HW30L	VHX0821N	SD42N
2525-M15-3	▲	▲	25	25	150	32	25	35	DN_1504_	LV4	SP4	LSPS4	HW30L	VHX0821	SD42
2525-M15-3N	●	●	25	25	150	32	25	35		LV4BN	SP4N	LSPS4	HW30L	VHX0821N	SD43N
3225-P15	▲	▲	32	25	170	32	32	35	DN_1506_	LV4B	SP4	LSPS4	HW30L	VHX0821	SD42
3225-P15N	●	●	32	25	170	32	32	35		LV4BN	SP4N	LSPS4	HW30L	VHX0821N	SD42N
3232-P15	▲	▲	32	32	170	40	32	35		LV4B	SP4	LSPS4	HW30L	VHX0821	SD42
3232-P15N	●	●	32	32	170	40	32	35		LV4BN	SP4N	LSPS4	HW30L	VHX0821N	SD42N
3232-P15-3	○	▲	32	32	170	40	32	35	DN_1504_	LV4	SP4	LSPS4	HW30L	VHX0821	SD42
3232-P15-3N	○	○	32	32	170	40	32	35		LV4BN	SP4N	LSPS4	HW30L	VHX0821N	SD43N
4040-P15	○	○	40	40	170	50	40	45	DN_1506_	LV4B	SP4	LSPS4	HW30L	VHX0821	SD42

PDNNR/L

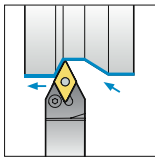

62,5°

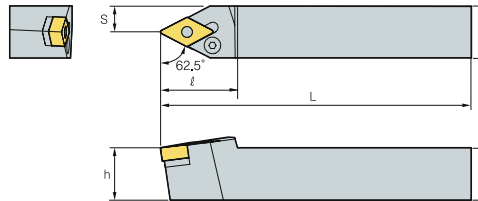

WSP



DN_

(mm)

Bezeichnung	L	R	H	W	L	S	h	ℓ	WSP	Kniehebel	Rohrstift	Rohrstift-Dorn	Schlüssel	Schraube	Zwischenlage
PDNNR/L 2020-K11-5N	●	●	20	20	125	8	20	37	DN_1105_	LV4B	SP4	LSPS4	HW30L	VHX0821	SD42
2020-K15	○	▲	20	20	125	8	20	37	DN_1506_	LV4B	SP4	LSPS4	HW30L	VHX0821	SD42
2020-K15N	○	●	20	20	125	8	20	37		LV4BN	SP4N	LSPS4	HW30L	VHX0821N	SD42N
2525-M11-5N	●	●	25	25	150	12,5	25	37	DN_1105_	LV4B	SP4	LSPS4	HW30L	VHX0821	SD42
2525-M15	▲	▲	25	25	150	12,5	25	37	DN_1506_	LV4B	SP4	LSPS4	HW30L	VHX0821	SD42
2525-M15N	●	●	25	25	150	12,5	25	37		LV4BN	SP4N	LSPS4	HW30L	VHX0821N	SD42N
2525-M15-3	○	●	25	25	150	12,5	25	37	DN_1504_	LV4	SP4	LSPS4	HW30L	VHX0821	SD42
2525-M15-3N	○	●	25	25	150	12,5	25	37		LV4BN	SP4N	LSPS4	HW30L	VHX0821N	SD43N
3232-M15		▲	32	32	150	16	32	37	DN_1506_	LV4B	SP4	LSPS4	HW30L	VHX0821	SD42
3232-P15	○	▲	32	32	170	16	32	37		LV4B	SP4	LSPS4	HW30L	VHX0821	SD42
3232-P15N	○	●	32	32	170	16	32	37		LV4BN	SP4N	LSPS4	HW30L	VHX0821N	SD42N
3232-P15-3N	○	○	32	32	170	16	32	37	DN_1504_	LV4BN	SP4N	LSPS4	HW30L	VHX0821N	SD43N
4025-M15	○	○	40	25	150	12,5	32	37	DN_1506_	LV4B	SP4	LSPS4	HW30L	VHX0821	SD42
4025-M15-3	○	○	40	25	150	12,5	25	37	DN_1504_	LV4	SP4	LSPS4	HW30L	VHX0821	SD42



PDNNN

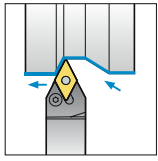

62,5°

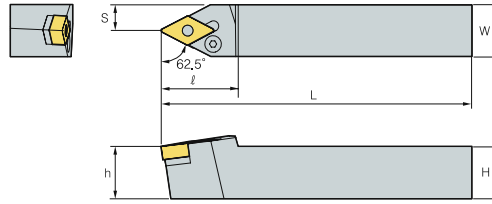

WSP



DN_

(mm)

Bezeichnung	N	H	W	L	S	h	ℓ	WSP	Kniehebel	Rohrstift	Rohrstift-Dorn	Schlüssel	Schraube	Zwischenlage
PDNNN 3232-S15	▲	32	32	250	16	32	37	DN_1506_	LVB	VHX0821	SD42	SP4	HW030L	LSPS4

PRDCN

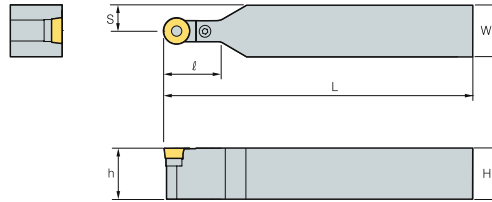
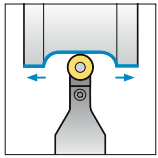

WSP



RCMX

(mm)

Bezeichnung	N	H	W	L	S	h	ℓ	WSP	Kniehebel	Rohrstift	Rohrstift-Dorn	Schlüssel	Schraube	Zwischenlage
PRDCN 2020-K12	▲	20	20	125	16	20	24	RCMX1204M0	LR12	SP3	LSPS3	HW25L	VHX0617	SR12
2020-M10	▲	20	20	150	15	20	24	RCMX1003M0	LR10	SP3	LSPS3	HW20L	VHX0514	SR10
2525-M10	▲	25	25	150	17,5	25	24		LR10	SP3	LSPS3	HW20L	VHX0514	SR10
2525-M12	▲	25	25	150	18,5	25	24	RCMX1204M0	LR12	SP3	LSPS3	HW25L	VHX0617	SR12
2525-Q16	▲	25	25	180	20,5	25	30	RCMX1606M0	LR16	SP4	LSPS4	HW25L	VHX0621	SR16
3225-Q12	▲	32	25	180	18,5	32	24	RCMX1204M0	LR12	SP3	LSPS3	HW25L	VHX0617	SR12
3225-Q16	▲	32	25	180	20,5	32	30	RCMX1606M0	LR16	SP4	LSPS4	HW25L	VHX0621	SR16
3232-Q16	▲	32	32	180	24	32	35		LR16	SP4	LSPS4	HW25L	VHX0621	SR16
3232-Q20	▲	32	32	180	26	32	40	RCMX2006M0	LR20	SP5-1	LSPS5	HW30L	VHX0823	SR20
4040-S25	▲	40	40	250	32,5	40	42	RCMX2507M0	LR25	SP6N	LSPS6	HW40L	VHX1030	SR25
4040-T25	▲	40	40	300	32,5	40	42		LR25	SP6N	LSPS6	HW40L	VHX1030	SR25
5050-U32	▲	50	50	350	41	50	52	RCMX3209M0	LR32	SP8N	LSPS8	HW50L	VHX1236	SR32

PRGCR/L

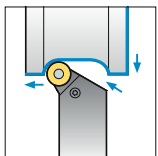

90°

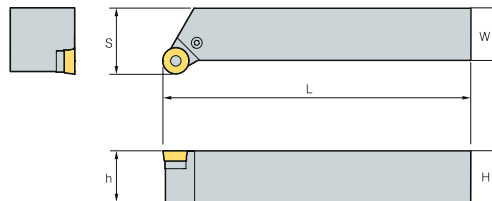

WSP



RCMX

(mm)

Bezeichnung	L	R	H	W	L	S	h	WSP	Kniehebel	Rohrstift	Rohrstift-Dorn	Schlüssel	Schraube	Zwischenlage
PRGCR/L 2020-K10	▲	▲	20	20	125	25	20	RCMX1003M0	LR10	SP3	LSPS3	HW20L	VHX0514	SR10
2020-K12	▲	▲	20	20	125	25	20	RCMX1204M0	LR12	SP3	LSPS3	HW25L	VHX0617	SR12
2525-M10	▲	▲	25	25	150	32	25	RCMX1003M0	LR10	SP3	LSPS3	HW20L	VHX0514	SR10
2525-M12	▲	▲	25	25	150	32	25	RCMX1204M0	LR12	SP3	LSPS3	HW25L	VHX0617	SR12
2525-M16	●	▲	25	25	150	32	25	RCMX1606M0	LR16	SP4	LSPS4	HW25L	VHX0621	SR16
3225-P12	▲	▲	32	25	170	32	32	RCMX1204M0	LR12	SP3	LSPS3	HW25L	VHX0617	SR12
3225-P16	▲	▲	32	25	170	32	32	RCMX1606M0	LR16	SP4	LSPS4	HW25L	VHX0621	SR16
3232-P20	▲	▲	32	32	170	40	32	RCMX2006M0	LR20	SP5-1	LSPS5	HW30L	VHX0823	SR20
4040-S25	▲	▲	40	40	250	50	40	RCMX2507M0	LR25	SP6N	LSPS6	HW40L	VHX1030	SR25



PSBNR/L

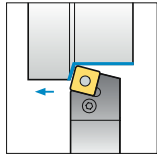

75°

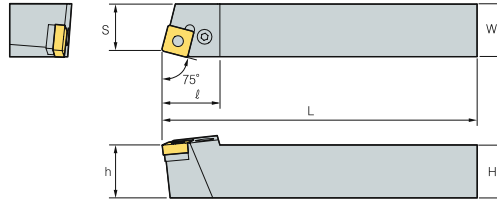

WSP



SN_

(mm)

Bezeichnung	L	R	H	W	L	S	h	ℓ	WSP	Kniehebel	Rohrstift	Rohrstift-Dorn	Schlüssel	Schraube	Zwischenlage
PSBNR/L 1616-H09	●	○	16	16	100	13	16	21	SN_0903_	LV3	SP3	LSPS3	HW25L	VHX0617	SS32
1616-H09N	○	○	16	16	100	13	16	21		LV3N	SP3N	LSPS3	HW25L	VHX0617N	SS32N
2020-K09	○	●	20	20	125	17	20	23		LV3	SP3	LSPS3	HW25L	VHX0617	SS32
2020-K09-4N	●	●	20	20	125	17	20	23	SN_0904_	LV3	SP3	LSPS3	HW25L	VHX0617	SS32
2020-K09N	○	○	20	20	125	17	20	23	SN_0903_	LV3N	SP3N	LSPS3	HW25L	VHX0617N	SS32N
2020-K12	▲	▲	20	20	125	17	20	28	SN_1204_	LV4	SP4	LSPS4	HW30L	VHX0821	SS42
2020-K12N	○	○	20	20	125	17	20	28		LV4N	SP4N	LSPS4	HW30L	VHX0820N	SS42N
2525-M09-4N	●	●	25	25	150	22	25	28	SN_0904_	LV4	SP4	LSPS4	HW30L	VHX0821	SS42
2525-M12	▲	▲	25	25	150	22	25	28	SN_1204_	LV4	SP4	LSPS4	HW30L	VHX0821	SS42
2525-M12N	○	○	25	25	150	22	25	28		LV4N	SP4N	LSPS4	HW30L	VHX0820N	SS42N
2525-M15	▲	▲	25	25	150	22	25	35	SN_1506_	LV5	SP5	LSPS5	HW30L	VHX0825	SS53
2525-M15N	○	○	25	25	150	22	25	35		LV5N	SP5N	LSPS5	HW30L	VHX0820AN	SS53N
3225-P12	●	●	32	32	170	22	32	28	SN_1204_	LV4	SP4	LSPS4	HW30L	VHX0821	SS42
3225-P12N	○	○	32	25	170	22	25	28		LV4N	SP4N	LSPS4	HW30L	VHX0820N	SS42N
3232-P12	○	○	32	32	170	27	32	28		LV4	SP4	LSPS4	HW30L	VHX0821	SS42
3232-P12N	○	○	32	32	170	27	32	28		LV4N	SP4N	LSPS4	HW30L	VHX0820N	SS42N
3232-P15	●	●	32	32	170	27	32	35	SN_1506_	LV5	SP5	LSPS5	HW30L	VHX0825	SS53
3232-P15N	○	○	32	32	170	27	32	35		LV5N	SP5N	LSPS5	HW30L	VHX0820AN	SS53N
3232-P19	▲	▲	32	32	170	27	32	40	SN_1906_	LV6N	SP6N	LSPS6	HW40L	VHX1027N	SS63N
4040-S19	▲	▲	40	40	250	35	40	40		LV6N	SP6N	LSPS6	HW40L	VHX1027N	SS63N
4040-S25	▲	▲	40	40	250	35	40	50	SN_2507_	LV8N	SP8N	LSPS8	HW50L	VHX1236N	SS84N
4040-S25-6	▲	▲	40	40	250	35	40	50	SN_2509_	LV8N	SP8N	LSPS8	HW50L	VHX1236N	SS84N
5050-T25	▲	▲	50	50	300	43	50	50	SN_2507_	LV8N	SP8N	LSPS8	HW50L	VHX1236N	SS84N
5050-T25-6	▲	▲	50	50	300	43	50	50	SNMG250924	LV8N	SP8N	LSPS8	HW50L	VHX1026N	SS84N



PSDNN

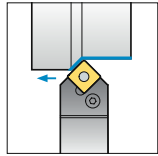

45°

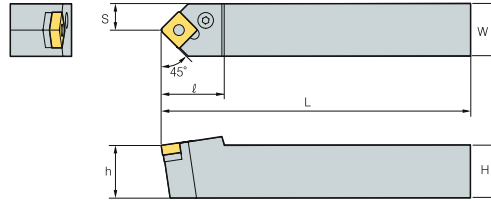

WSP



SN_

(mm)

Bezeichnung	N	H	W	L	S	h	ℓ	WSP	Kniehebel	Rohrstift	Rohrstift-Dorn	Schlüssel	Schraube	Zwischenlage
PSDNN 1616-H09	▲	16	16	100	8	16	23	SN_0903_	LV3	SP3	LSPS3	HW25L	VHX0617	SS32
1616-H09N	○	16	16	100	8	16	23		LV3N	SP3N	LSPS3	HW25L	VHX0617N	SS32N
2020-K09-4N	●	20	20	100	8	16	23	SN_0904_	LV3N	SP3N	LSPS3	HW25L	VHX0617N	SS32N
2020-K12	▲	20	20	125	10	20	30	SN_1204_	LV4	SP4	LSPS4	HW30L	VHX0821	SS42
2020-K12N	○	20	20	125	10	20	30		LV4N	SP4N	LSPS4	HW30L	VHX0820N	SS42N
2525-M09-4N	●	25	25	150	12,5	25	30	SN_0904_	LV4	SP4	LSPS4	HW30L	VHX0821	SS42
2525-M12	▲	25	25	150	12,5	25	30	SN_1204_	LV4	SP4	LSPS4	HW30L	VHX0821	SS42
2525-M12N	○	25	25	150	12,5	20	30		LV4N	SP4N	LSPS4	HW30L	VHX0820N	SS42N
2525-M15	▲	25	25	150	12,5	25	40	SN_1506_	LV5	SP5	LSPS5	HW30L	VHX0825	SS53
2525-M15N	○	25	25	150	12,5	25	40		LV5N	SP5N	LSPS5	HW30L	VHX0820AN	SS53N
3225-P12	▲	32	25	170	12,5	32	30	SN_1204_	LV4	SP4	LSPS4	HW30L	VHX0821	SS42
3225-P12N	○	32	25	170	12,5	32	30		LV4N	SP4N	LSPS4	HW30L	VHX0820N	SS42N
3225-P19	▲	32	25	170	12,5	32	40	SN_1906_	LV6N	SP6N	LSPS6	HW40L	VHX1027N	SS63N
3232-P12	▲	32	32	170	16	32	40	SN_1204_	LV4	SP4	LSPS4	HW30L	VHX0821	SS42
3232-P12N	○	32	32	170	16	32	40		LV4N	SP4N	LSPS4	HW30L	VHX0820N	SS42N
3232-P15	○	32	32	170	16	32	40	SN_1506_	LV5	SP5	LSPS5	HW30L	VHX0825	SS53
3232-P15N	○	32	32	170	16	32	40		LV5N	SP5N	LSPS5	HW30L	VHX0820AN	SS53N
3232-P19	▲	32	32	170	16	32	40	SN_1906_	LV6N	SP6N	LSPS6	HW40L	VHX1027N	SS63N
4040-S19	▲	40	40	250	20	40	40		LV6N	SP6N	LSPS6	HW40L	VHX1027N	SS63N
4040-S25	●	40	40	250	20	40	50	SN_2507_	LV8N	SP8N	LSPS8	HW50L	VHX1236N	SS84N
4040-S25-6	▲	40	40	250	20	40	50	SN_2509_	LV8N	SP8N	LSPS8	HW50L	VHX1236N	SS84N
5050-T25	●	50	50	300	25	50	50	SN_2507_	LV8N	SP8N	LSPS8	HW50L	VHX1236N	SS84N
5050-T25-6	●	50	50	300	25	50	50	SN_2509_	LV8N	SP8N	LSPS8	HW50L	VHX1236N	SS84N



PSKNR/L

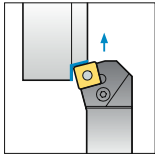

75°

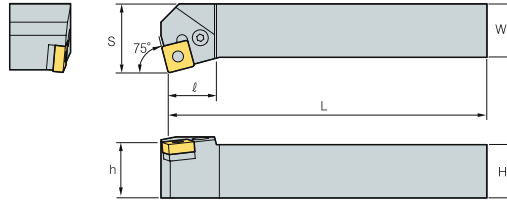

WSP



SN_

(mm)

Bezeichnung	L	R	H	W	L	S	h	ℓ	WSP	Kniehebel	Rohrstift	Rohrstift-Dorn	Schlüssel	Schraube	Zwischenlage
PSKNR/L 1616-H09	▲	○	16	16	100	20	16	17	SN_0903_	LV3	SP3	LSPS3	HW25L	VHX0617	SS32
	○	○	16	16	100	20	16	17		LV3N	SP3N	LSPS3	HW25L	VHX0617N	SS32N
2020-K09	○	●	20	20	125	25	20	20	SN_0904_	LV3	SP3	LSPS3	HW25L	VHX0617	SS32
2020-K09-4N	●	●	20	20	125	25	20	20		LV3N	SP3N	LSPS3	HW25L	VHX0617N	SS32N
2020-K09N	○	○	20	20	125	25	20	20	SN_1204_	LV4	SP4	LSPS4	HW30L	VHX0821	SS42
2020-K12	●	●	20	20	125	25	20	23		LV4N	SP4N	LSPS4	HW30L	VHX0820N	SS42N
2020-K12N	○	○	20	20	125	25	20	26	SN_0904_	LV4	SP4	LSPS4	HW30L	VHX0821	SS42
2525-M09-4N	●	●	25	25	150	32	25	23		LV4N	SP4N	LSPS4	HW30L	VHX0820N	SS42N
2525-M12	●	▲	25	25	150	32	25	23	SN_1204_	LV4	SP4	LSPS4	HW30L	VHX0821	SS42
2525-M12N	○	○	25	25	150	32	25	26		LV4N	SP4N	LSPS4	HW30L	VHX0820N	SS42N
2525-M15	○	●	25	25	150	32	25	28	SN_1506_	LV5	SP5	LSPS5	HW30L	VHX0825	SS53
2525-M15N	○	○	25	25	150	32	25	32		LV5N	SP5N	LSPS5	HW30L	VHX0820AN	SS53N
3232-P12	○	▲	32	32	170	40	32	23	SN_1204_	LV4	SP4	LSPS4	HW30L	VHX0821	SS42
3232-P12N	○	○	32	32	170	40	32	26		LV4N	SP4N	LSPS4	HW30L	VHX0820N	SS42N
3232-P15	●	●	32	32	170	40	32	28	SN_1506_	LV5	SP5	LSPS5	HW30L	VHX0825	SS53
3232-P15N	○	○	32	32	170	40	32	32		LV5N	SP5N	LSPS5	HW30L	VHX0820AN	SS53N
3232-P19	▲	▲	32	32	170	40	32	41,5	SN_1906_	LV6N	SP6N	LSPS6	HW40L	VHX1027N	SS63N
4040-S19	●	▲	40	40	250	50	40	41,5		LV6N	SP6N	LSPS6	HW40L	VHX1027N	SS63N
4040-S25	○	●	40	40	250	50	40	46	SN_2507_	LV8N	SP8N	LSPS8	HW50L	VHX1236N	SS84N
4040-S25-6	○	●	40	40	250	50	40	46		LV8N	SP8N	LSPS8	HW50L	VHX1236N	SS84N
5050-T25-6	○	●	50	50	300	60	50	37,5	LV8N	SP8N	LSPS8	HW50L	VHX1236N	SS84N	



PSSNR/L

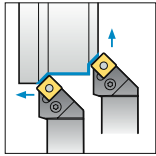

45°

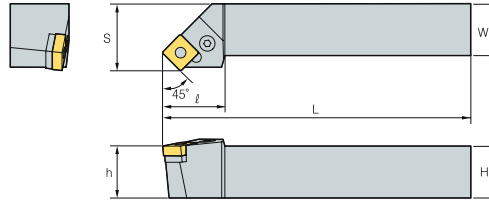

WSP



SN_

Bezeichnung		L	R	H	W	L	S	h	ℓ	WSP	Kniehebel	Rohrstift	Rohrstift-Dorn	Schlüssel	Schraube	Zwischenlage
PSSNR/L	1616-H09	▲	▲	16	16	100	20	16	25	SN_0903_	LV3	SP3	LSPS3	HW25L	VHX0617	SS32
	1616-H09N	○	○	16	16	100	20	16	25		LV3N	SP3	LSPS3	HW25L	VHX0617N	SS32N
	2020-K09-4N	●	●	20	20	125	25	20	30	SN_0904_	LV4	SP4	LSPS4	HW30L	VHX0821	SS42
	2020-K12	▲	▲	20	20	125	25	20	30	SN_1204_	LV4	SP4	LSPS4	HW30L	VHX0821	SS42
	2020-K12N	○	○	20	20	125	25	20	30		LV4N	SP4	LSPS4	HW30L	VHX0821N	SS42N
	2525-M09-4N	●	●	25	25	150	32	25	36	SN_0904_	LV4	SP4	LSPS4	HW30L	VHX0821	SS42
	2525-M12	▲	▲	25	25	150	32	25	36	SN_1204_	LV4	SP4	LSPS4	HW30L	VHX0821	SS42
	2525-M12N	○	○	25	25	150	32	25	36		LV4N	SP4	LSPS4	HW30L	VHX0821N	SS42N
	2525-M15	▲	▲	25	25	150	32	25	36	SN_1506_	LV5	SP5	LSPS5	HW30L	VHX0825	SS53
	2525-M15N	○	○	25	25	150	32	25	36		LV5N	SP5	LSPS5	HW30L	VHX08209N	SS53N
	3225-P12		▲	32	25	170	40	32	35	SN_1204_	LV4	SP4	LSPS4	HW30L	VHX0821	SS42
	3225-P12N	○	○	32	25	170	32	32	45		LV4N	SP4	LSPS4	HW30L	VHX0821N	SS42N
	3232-P12	▲	▲	32	32	170	40	32	40		LV4	SP4	LSPS4	HW30L	VHX0821	SS42
	3232-P12N	○	○	32	32	170	40	32	40		LV4N	SP4	LSPS4	HW30L	VHX0821N	SS42N
	3232-P15	▲	▲	32	32	170	40	32	45	SN_1506_	LV5	SP5	LSPS5	HW30L	VHX0825	SS53
	3232-P15N	○	○	32	32	170	40	32	45		LV5N	SP5	LSPS5	HW30L	VHX08209N	SS53N
	3232-P19	▲	▲	32	32	170	40	32	41,5	SN_1906_	LV6N	SP6N	LSPS6	HW40L	VHX1027N	SS63N
	4040-P25	○		40	40	170	50	40	48	SN_2507_	LV8N	SP8N	LSPS8	HW50L	VHX1236N	SS84N
	4040-R19	●	●	40	40	200	50	40	41,5	SN_1906_	LV6N	SP6N	LSPS6	HW40L	VHX1027N	SS63N
	4040-S19	▲	▲	40	40	250	50	40	41,5		LV6N	SP6N	LSPS6	HW40L	VHX1027N	SS63N
4040-S25	○	▲	40	40	250	50	40	48	SN_2507_	LV8N	SP8N	LSPS8	HW50L	VHX1236N	SS84N	
4040-S25-6	●	▲	40	40	250	50	40	48	SN_2509_	LV8N	SP8N	LSPS8	HW50L	VHX1236N	SS84N	

PTFNR/L

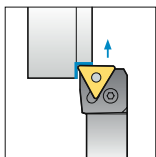

90°

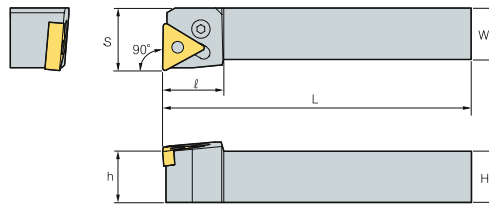

WSP



TN_

Bezeichnung		L	R	H	W	L	S	h	ℓ	WSP	Kniehebel	Rohrstift	Rohrstift-Dorn	Schlüssel	Schraube	Zwischenlage
PTFNR/L	1616-H16	●	●	16	16	100	20	16	20	TN_1604_	LV3	SP3	LSPS3	HW25L	VHX0617	ST317
	1616-H16N	○	○	16	16	100	20	16	20		LV3N	SP3N	LSPS3	HW25L	VHX0617N	ST317N
	2020-K16	▲	▲	20	20	125	25	20	20		LV3	SP3	LSPS3	HW25L	VHX0617	ST317
	2020-K16N	○	○	20	20	125	25	20	20		LV3N	SP3N	LSPS3	HW25L	VHX0617N	ST317N
	2525-M16	▲	▲	25	25	150	32	25	20		LV3	SP3	LSPS3	HW25L	VHX0617	ST317
	2525-M16N	○	○	25	25	150	32	25	20		LV3N	SP3N	LSPS3	HW25L	VHX0617N	ST317N
	2525-M22	●	●	25	25	150	32	25	25	TN_2204_	LV4	SP4	LSPS4	HW30L	VHX0821	ST42
	2525-M22N	○	○	25	25	150	32	25	25		LV4N	SP4N	LSPS4	HW30L	VHX0820N	ST42N
	3232-P22	▲	▲	32	32	170	40	32	25		LV4	SP4	LSPS4	HW30L	VHX0821	ST42
	3232-P22N	○	○	32	32	170	40	32	25		LV4N	SP4N	LSPS4	HW30L	VHX0820N	ST42N
	3232-P27	○	○	32	32	170	40	32	34	TN_2706_	LV5	SP5	LSPS5	HW30L	VHX0825	ST53
	3232-P27N	○	○	32	32	170	40	32	34		LV5AN	SP5N	LSPS5	HW30L	VHX0823N	ST53N
	4040-S27	○	○	40	40	250	50	40	34		LV5	SP5	LSPS5	HW30L	VHX0825	ST53
	4040-S27N	○	○	40	40	250	50	40	34		LV5AN	SP5N	LSPS5	HW30L	VHX0823N	ST53N



PTGNR/L

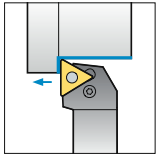

90°

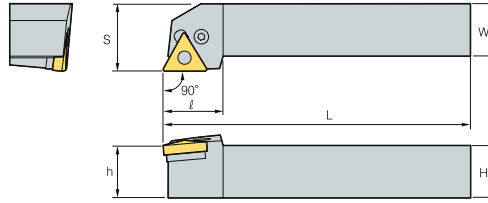

WSP



TN_

(mm)

Bezeichnung	L	R	H	W	L	S	h	ℓ	WSP	Kniehebel	Rohrstift	Rohrstift-Dorn	Schlüssel	Schraube	Zwischenlage
PTGNR/L 1212-F11	▲	▲	12	12	80	16	12	16	TN_1103_	LV2			HW20L	VHX0509B	
1616-H11	○	▲	16	16	100	20	16	18		LV2			HW20L	VHX0509B	
1616-H16	▲	▲	16	16	100	20	16	20	TN_1604_	LV3	SP3	LSPS3	HW25L	VHX0617	ST317
1616-H16N	○	○	16	16	100	20	16	20		LV3N	SP3N	LSPS3	HW25L	VHX0617N	ST317N
2020-K11	▲	○	20	20	125	25	20	19	TN_1103_	LV2			HW20L	VHX0509B	
2020-K16	▲	▲	20	20	125	25	20	20	TN_1604_	LV3	SP3	LSPS3	HW25L	VHX0617	ST317
2020-K16N	○	○	20	20	125	25	20	20		LV3N	SP3N	LSPS3	HW25L	VHX0617N	ST317N
2525-M11	○	●	25	25	150	32	25	20	TN_1103_	LV2			HW20L	VHX0509B	
2525-M16	▲	▲	25	25	150	32	25	20	TN_1604_	LV3	SP3	LSPS3	HW25L	VHX0617	ST317
2525-M16N	○	○	25	25	150	32	25	20		LV3N	SP3N	LSPS3	HW25L	VHX0617N	ST317N
2525-M22	▲	▲	25	25	150	32	25	28	TN_2204_	LV4	SP4	LSPS4	HW30L	VHX0821	ST42
2525-M22N	○	○	25	25	150	32	25	28		LV4N	SP4N	LSPS4	HW30L	VHX0820N	ST42N
2525-R22		○	25	25	200	32	25	28		LV4	SP4	LSPS4	HW30L	VHX0821	ST42
3232-P16	▲	▲	32	32	170	40	32	20	TN_1604_	LV3	SP3	LSPS3	HW25L	VHX0617	ST317
3232-P16N	○	○	32	32	170	40	32	20		LV3N	SP3N	LSPS3	HW25L	VHX0617N	ST317N
3232-P22	▲	▲	32	32	170	40	32	28	TN_2204_	LV4	SP4	LSPS4	HW30L	VHX0821	ST42
3232-P22N	○	○	32	32	170	40	32	28		LV4N	SP4N	LSPS4	HW30L	VHX0820N	ST42N
3232-P27	○	●	32	32	170	40	32	33	TN_2706_	LV5	SP5	LSPS5	HW30L	VHX0825	T53
3232-P27N	○	○	32	32	170	40	32	33		LV5AN	SP5N	LSPS5	HW30L	VHX0823N	ST53N
4040-S27	○	▲	40	40	250	50	40	33		LV5	SP5	LSPS5	HW30L	VHX0825	T53
4040-S27N	○	○	40	40	250	50	40	33		LV5AN	SP5N	LSPS5	HW30L	VHX0823N	ST53N



PTTNR/L

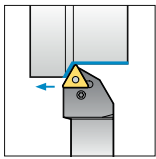

60°

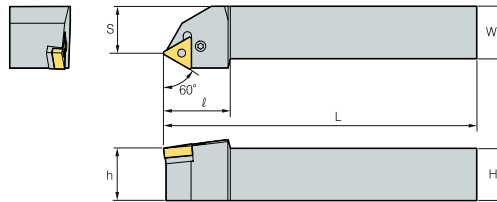

WSP



TN_

(mm)

Bezeichnung	L	R	H	W	L	S	h	ℓ	WSP	Kniehebel	Rohrstift	Rohrstift-Dorn	Schlüssel	Schraube	Zwischenlage
PTTNR/L 1616-H16	○	○	16	16	100	13	16	25	TN_1604_	LV3	SP3	LSPS3	HW25L	VHX0617	ST317
1616-H16N	○	○	16	16	100	13	16	25		LV3N	SP3N	LSPS3	HW25L	VHX0617N	ST317N
2020-K16	○	▲	20	20	125	17	20	25		LV3	SP3	LSPS3	HW25L	VHX0617	ST317
2020-K16N	○	○	20	20	125	17	20	25		LV3N	SP3N	LSPS3	HW25L	VHX0617N	ST317N
2525-K16		○	25	25	125	22	25	32		LV3	SP3	LSPS3	HW25L	VHX0617	ST317
2525-M16	▲	▲	25	25	150	22	25	32		LV3	SP3	LSPS3	HW25L	VHX0617	ST317
2525-M16N	○	○	25	25	150	22	25	32		LV3N	SP3N	LSPS3	HW25L	VHX0617N	ST317N
2525-M22	▲	▲	25	25	150	22	25	32	TN_2204_	LV4	SP4	LSPS4	HW30L	VHX0821	ST42
2525-M22N	○	○	25	25	150	22	25	32		LV4N	SP4N	LSPS4	HW30L	VHX0820N	ST42N



PWLNR/L

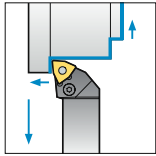

95°

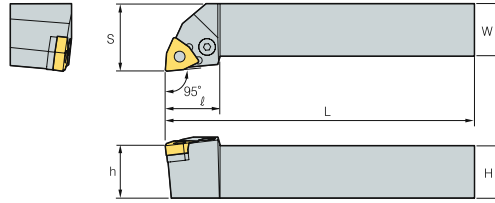

WSP



WN_

(mm)

Bezeichnung	L	R	H	W	L	S	h	ℓ	WSP	Kniehebel	Rohrstift	Rohrstift-Dorn	Schlüssel	Schraube	Zwischenlage
PWLNR/L 1616-H06	▲	▲	16	16	100	20	16	20	WN_0604_	LV3	SP3	LSPS3	HW25L	VHX0617	SW317
1616-H06N	○	○	16	16	100	20	16	20		LV3N	SP3N	LSPS3	HW25L	VHX0617N	SW317N
2020-K06	▲	▲	20	20	125	25	20	20		LV3	SP3	LSPS3	HW25L	VHX0617	SW317
2020-K06N	○	○	20	20	125	25	20	20		LV3N	SP3N	LSPS3	HW25L	VHX0617N	SW317N
2020-K08	▲	▲	20	20	125	25	20	26	WN_0804_	LV4	SP4	LSPS4	HW30L	VHX0821	SW42
2020-K08N	○	○	20	20	125	25	20	26		LV4N	SP4N	LSPS4	HW30L	VHX0820N	SW42N
2525-M06	▲	▲	25	25	150	32	25	20	WN_0604_	LV3	SP3	LSPS3	HW25L	VHX0617	SW317
2525-M06N	○	○	25	25	150	32	25	20		LV3N	SP3N	LSPS3	HW25L	VHX0617N	SW317N
2525-M08	▲	▲	25	25	150	32	25	26	WN_0804_	LV4	SP4	LSPS4	HW30L	VHX0821	SW42
2525-M08N	○	○	25	25	150	32	25	26		LV4N	SP4N	LSPS4	HW30L	VHX0820N	SW42N
3232-M08		▲	32	32	150	40	32	33		LV4	SP4	LSPS4	HW30L	VHX0821	SW42
3232-P08		▲	32	32	170	40	32	33		LV4	SP4	LSPS4	HW30L	VHX0821	SW42



WTENN

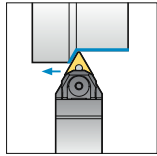

60°

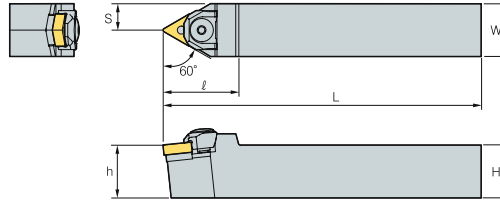

WSP



TN_

(mm)

Bezeichnung	N	H	W	L	S	h	ℓ	WSP	Keilklemme	Mutter	Rohrstift	Schlüssel	Schraube	Sicherungsring	Zwischenlage	
WTENN	2020-K16	●	20	20	125	10	20	36	TN_1604_	CMH6R6	N0407	SP3M-1	HW30L	MHX0626	ER04	ST32M
	2525-M16	●	25	25	150	12,5	25	36		CMH6R6	N0407	SP3M	HW30L	MHX0626	ER04	ST32M
	2525-M22	●	25	25	150	12,5	25	42	TN_2204_	CMH6R1	N0508	SP4M	HW30L	MHX0626	ER04	ST43M
	3232-P22	●	32	32	170	16	32	42		CMH6R1	N0508	SP4M	HW30L	MHX0626	ER04	ST43M

WTJNR/L

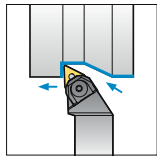

93°

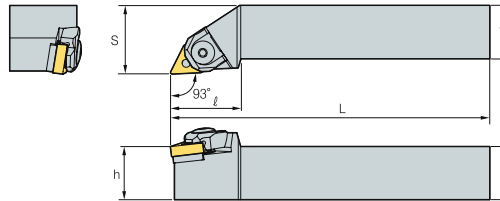

WSP



TN_

(mm)

Bezeichnung	L	R	H	W	L	S	h	ℓ	WSP	Keilklemme	Mutter	Rohrstift	Schlüssel	Schraube	Sicherungsring	Zwischenlage	
WTJNR/L	2020-K16	●	●	20	20	125	25	20	33	TN_1604_	CMH6R6	N0407	SP3M-1	HW30L	MHX0626	ER04	ST32M
	2020-M16		○	20	20	150	25	20	33		CMH6R6	N0407	SP3M	HW30L	MHX0626	ER04	ST32M
	2525-M16	●	●	25	25	150	32	25	33		CMH6R6	N0407	SP3M	HW30L	MHX0626	ER04	ST32M
	2525-M22	●	●	25	25	150	32	25	35	TN_2204_	CMH6R1	N0508	SP4M	HW30L	MHX0626	ER04	ST43M
	2525-P22		○	25	25	170	32	25	35		CMH6R1	N0508	SP4M	HW30L	MHX0626	ER04	ST43M
	3225-P16	○	○	32	25	170	40	32	33	TN_1604_	CMH6R6	N0407	SP3M	HW30L	MHX0626	ER04	ST32M
	3232-P16	●	●	32	32	170	40	32	33		CMH6R6	N0407	SP3M	HW30L	MHX0626	ER04	ST32M
3232-P22	●	●	32	32	170	40	32	35	TN_2204_	CMH6R1	N0508	SP4M	HW30L	MHX0626	ER04	ST43M	

WTXNR/L

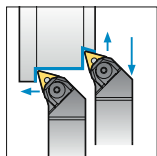

105°

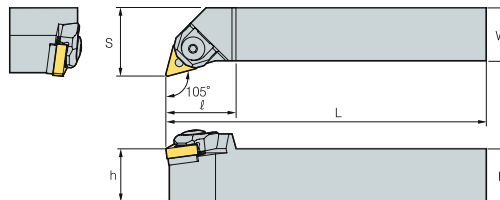

WSP



TN_

(mm)

Bezeichnung	L	R	H	W	L	S	h	ℓ	WSP	Keilklemme	Mutter	Rohrstift	Schlüssel	Schraube	Sicherungsring	Zwischenlage	
WTXNR/L	2020-K16	●	●	20	20	125	25	20	30	TN_1604_	CMH6R6	N0407	SP3M-1	HW25L HW30L	MHX0626	ER04	ST32M
	2525-M16	●	●	25	25	150	32	25	33		CMH6R6	N0407	SP3M	HW25L HW30L	MHX0626	ER04	ST32M
	3232-P16		○	32	32	170	40	32	33		CMH6R6	N0407	SP3M	HW25L HW30L	MHX0626	ER04	ST32M



WWLNR/L

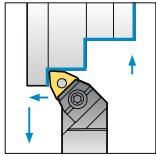

95°

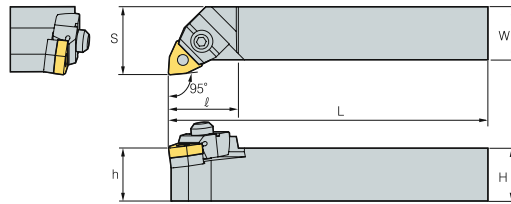

WSP



WN_

Bezeichnung		L	R	H	W	L	S	h	ℓ	WSP	C-Ring	Keilklemme	Mutter	Rohrstift	Schlüssel	Schraube	Zwischenlage
											(mm)						
WWLNR/L	2020-K08	●	●	20	20	125	25	20	32	WN_0804_							
	2525-M08	●	●	25	25	150	32	25	33		CR05	CMH6R/L3	N0508	SP2M	HW30L HW40L	MHX0630	SW43M
	3225-M08		○	32	25	150	40	32	33		CR05	CMH6R2	N0508	SP4M	HW30L HW40L	MHX0630	SW43M
	3232-P08	●	●	32	32	170	40	32	33		CR05	CMH6R2	N0508	SP4M	HW30L HW40L	MHX0630	SW43M



CKJNR/L

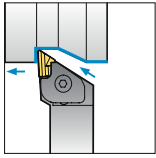

93°

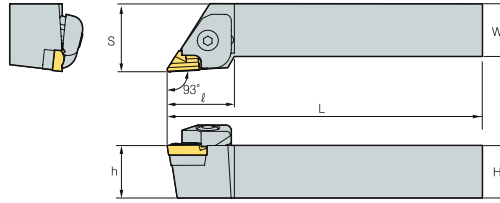

WSP



KN_

(mm)

Bezeichnung	L	R	H	W	L	S	h	ℓ	WSP	Feder	Klemme	Klemmschraube	Lagenschraube	Schlüssel	Stift	Zwischenlage
CKJNL 2020-K16	▲		20	20	125	25	20	32	KN_1604_L	SR3 SR4	CTH6L1	CHX0625	SHX0310	HW20L HW40L	PN0515	SK33CL
	▲		25	25	150	32	25	32								
	▲		32	32	170	40	32	32								
	▲		40	40	200	50	40	32								
CKJNR 2020-K16		▲	20	20	125	25	20	32	KN_1604_R	SR3 SR4	CTH6R1	CHX0625	SHX0310	HW20L HW40L	PN0515	SK33C
		▲	25	25	150	32	25	32								
		○	32	25	150	32	32	32								
		▲	32	25	170	32	32	32								
		▲	32	32	170	40	32	32								
		▲	40	40	200	50	40	32								



CKNNR/L

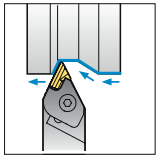

62,5°

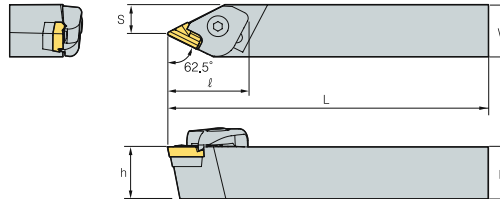

WSP



KN_

(mm)

Bezeichnung	L	R	H	W	L	S	h	ℓ	WSP	Feder	Klemme	Klemmschraube	Lagenschraube	Schlüssel	Stift	Zwischenlage
CKNNL 2525-M16	○		25	25	150	14,3	25	37	KN_1604_L	SR3 SR4	CTH6L1	CHX0625	SHX0310	HW20L HW40L	PN0515	SK33CL
	●		32	32	170	16,8	32	37								
CKNNR 2525-M16		▲	25	25	150	14,3	25	37	KN_1604_R	SR3 SR4	CTH6R1	CHX0625	SHX0310	HW20L HW40L	PN0515	SK33C
		▲	32	32	170	16,8	32	37								



CSDPN

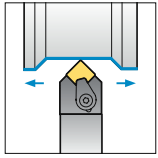

45°

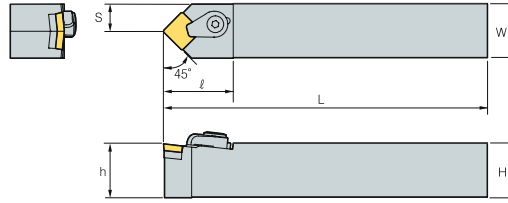

WSP

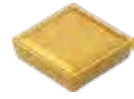

SP_R

Bezeichnung		N	H	W	L	S	h	ℓ	WSP	C-Ring	Klemme	Klemmschraube	Rohrstift	Schlüssel	Zwischenlage
CSDPN	1616-H09	○	16	16	100	8	16	30	SP_R0903_	CR03C	CH53R1	CH0515C	SP3C	HW25L	SS32C
	2525-M12	▲	25	25	150	12,5	25	35	SP_R1203_	CR04C	CH6R5	CHX0622C	SP3C	HW25L	SS42C

(mm)

CSKPR/L

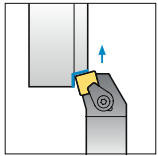

75°

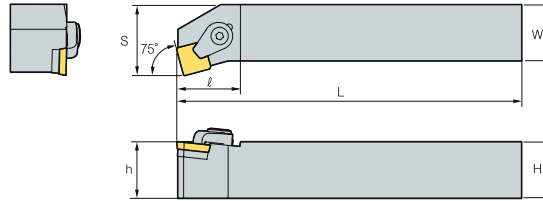

WSP

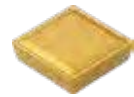

SP_R

Bezeichnung		L	R	H	W	L	S	h	ℓ	WSP	C-Ring	Klemme	Klemmschraube	Rohrstift	Schlüssel	Zwischenlage
CSKPR/L	2525-M12	○	▲	25	25	150	32	20	32	SP_R1203_	CR04C	CH6R5	CHX0622C	SP3C	HW30L	SS42C

(mm)

CTFPR/L

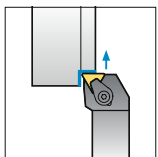

90°

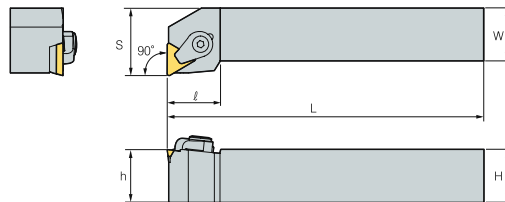

WSP



TP_R

Bezeichnung		L	R	H	W	L	S	h	ℓ	WSP	C-Ring	Klemme	Klemmschraube	Rohrstift	Schlüssel	Zwischenlage
CTFPR/L	2020-K16	▲	▲	20	20	125	25	20	32	TP_R1603_	CR04C	CH6R5	CHX0622C	SP3C	HW30L	ST32C
	2525-M16	▲	▲	25	25	150	32	25	32		CR04C	CH6R5	CHX0622C	SP3C	HW30L	ST32C

(mm)



CTGPR/L

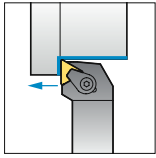

90°

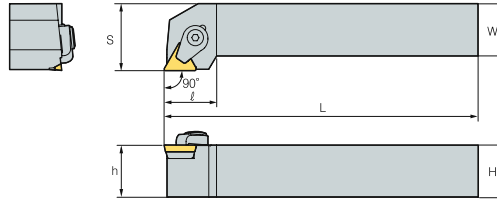

WSP



TP_R

(mm)

Bezeichnung	L	R	H	W	L	S	h	ℓ	WSP	C-Ring	Klemme	Klemmschraube	Rohrstift	Schlüssel	Zwischenlage	
CTGPR/L	1212-F11	○	●	12	12	80	16	12	20	TP_R1103_	CR03C	CH53R1	CHX0515C		HW25L	
	1616-H11	○	●	16	16	100	20	16	20		CR03C	CH53R1	CHX0515C		HW25L	
	2020-K11	▲	▲	20	20	125	25	20	20		CR03C	CH53R1	CHX0515C		HW25L	
	2020-K16	▲	▲	20	20	125	25	20	25	TP_R1603_	CR04C	CH6R5	CHX0622C	SP3C	HW30L	ST32C
	2525-M16	▲	▲	25	25	150	32	25	25		CR04C	CH6R5	CHX0622C	SP3C	HW30L	ST32C
	2525-M22	○	▲	25	25	150	32	25	32	TP_R2204_	CR05C	CH83R1	CHX0823C	SP4C	HW40L	ST43C
	3232-P22	▲	▲	32	32	170	40	32	32		CR05C	CH83R1	CHX0823C	SP4C	HW40L	ST43C



MCKNR/L

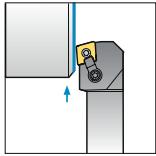

75°

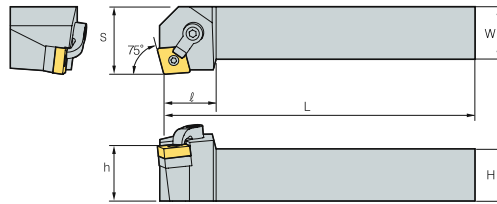

WSP



CN_

Bezeichnung		L	R	H	W	L	S	h	ℓ	WSP	Klemme	Klemmschraube	Rohrstift	Schlüssel	Zwischenlage	
MCKNR/L	2020-K12	○	○	20	20	125	25	20	32	CN_1204_						
	2525-M12	○	●	25	25	150	32	25	32							
	3232-P12	○	○	32	32	170	40	32	32							

(mm)

MCLNR/L

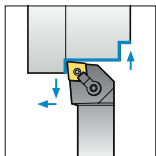

95°

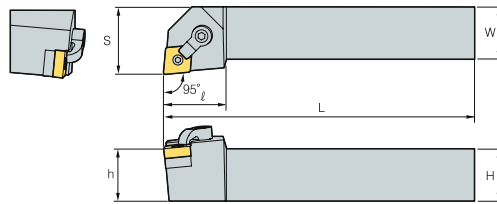

WSP



CN_

Bezeichnung		L	R	H	W	L	S	h	ℓ	WSP	Klemme	Klemmschraube	Rohrstift	Schlüssel	Zwischenlage	
MCLNR/L	1616-H09	○	○	16	16	100	20	16	25	CN_0903_						
	2020-K09	○	○	20	20	125	25	20	25							
	2020-K12	○	○	20	20	125	25	20	32	CN_1204_						
	2525-M09	○	○	25	25	150	32	25	25	CN_0903_						
	2525-M12	○	●	25	25	150	32	25	32	CN_1204_						
	2525-M16	○	●	25	25	150	32	25	33	CN_1606_						
	2525-M19	○	○	25	25	150	32	25	38	CN_1906_						
	3225-P12	○	○	32	25	170	32	32	32	CN_1204_						
	3232-P12	○	●	32	32	170	40	32	32							
	3232-P16	○	●	32	32	170	40	32	33	CN_1606_						
	3232-P19	○	○	32	32	170	40	32	38	CN_1906_						
	4040-S16	○	○	40	40	250	50	40	33	CN_1606_						
	4040-S19	○	○	40	40	250	50	40	38	CN_1906_						
	4040-S25	○	○	40	40	250	50	40	38	CN_2507_						

(mm)



MCMNN

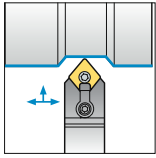

50°

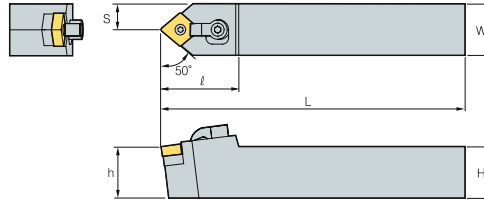

WSP



CN_

Bezeichnung		N	H	W	L	S	h	ℓ	WSP	Klemme	Klemmschraube	Rohrstift	Schlüssel	Zwischenlage
MCMNN	2020-K12	○	20	20	125	10	20	32	CN_1204_	CDH6N	DHA1/4-25	SP4D	HW23.8L HW31.8L	SC43D
	2525-M12	○	25	25	150	12,5	25	32		CDH6N	DHA1/4-25	SP4D	HW23.8L HW31.8L	SC43D
	2525-M16	○	25	25	150	12,5	25	40	CN_1606_	CDH8N	DHA5/16-32	SP5D	HW31.8L HW39.7L	SC53S
	3232-P12	○	32	32	170	16	32	32	CN_1204_	CDH6N	DHA1/4-25	SP4D	HW23.8L HW31.8L	SC43D
	3232-P16	○	32	32	170	16	32	40		CN_1606_	CDH8N	DHA5/16-32	SP5D	HW31.8L HW39.7L
	3232-P19	○	32	32	170	16	32	40	CN_1906_	CDH8N	DHA5/16-32	SP6D	HW35.7L HW39.7L	SD63D
	4040-S19	○	40	40	250	20	40	32		CDH8N	DHA5/16-32	SP6D	HW35.7L HW39.7L	SD63D

(mm)

MCRNR/L

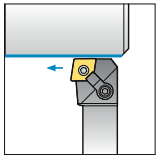

75°

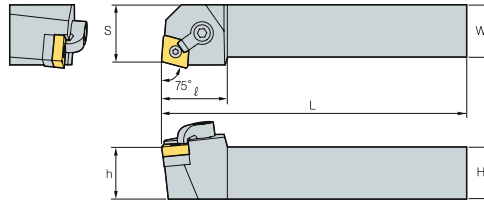

WSP



CN_

Bezeichnung		L	R	H	W	L	S	h	ℓ	WSP	Klemme	Klemmschraube	Rohrstift	Schlüssel	Zwischenlage
MCRNR/L	2020-K12	○	○	20	20	125	22	20	32	CN_1204_	CDH8N1	DHA5/16-32	SP4D	HW23.8L HW39.7L	SC43D
	2525-M12	○	○	25	25	150	27	25	32		CDH8N1	DHA5/16-32	SP4D	HW23.8L HW39.7L	SC43D
	2525-M16	○	○	25	25	150	27	25	33	CN_1606_	CDH8N1	DHA5/16-32	SP5D	HW31.8L HW39.7L	SC53D
	3232-P16	○	○	32	32	170	35	32	33		CDH8N1	DHA5/16-32	SP5D	HW31.8L HW39.7L	SC53D
	3232-P19	○	○	32	32	170	35	32	38	CN_1906_	CDH8N1	DHA5/16-32	SP6D	HW35.7L HW39.7L	SC63D
	3232-R19		○	32	32	200	35	32	38		CDH8N1	DHA5/16-32	SP6D	HW39.7L	SC63D
	4040-S19	○	○	40	40	250	43	40	38	CDH8N1	DHA5/16-32	SP6D	HW35.7L HW39.7L	SC63D	

(mm)



MDJNR/L

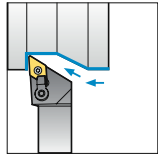

93°

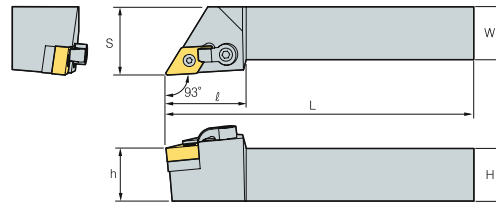

WSP



DN_

Bezeichnung		L	R	H	W	L	S	h	ℓ	WSP	Klemme	Klemmschraube	Rohrstift	Schlüssel	Zwischenlage
MDJNR/L	2020-K11	○	○	20	20	125	25	20	32	DN_1104_	CDH6N	DHA1/4-19	SP3D	HW19.8L HW31.8L	SD32D
	2020-K15	○	○	20	20	125	25	20	36	DN_1506_	CDH6N	DHA1/4-25	SP4DL	HW23.8L HW31.8L	SD43D
	2020-K15-3	○	●	20	20	125	25	20	36	DN_1504_	CDH6N	DHA1/4-25	SP4D	HW23.8L HW31.8L	SD43D
	2525-M11	○	○	25	25	150	32	25	32	DN_1104_	CDH6N	DHA1/4-19	SP3D	HW19.8L HW31.8L	SD32D
	2525-M15	○	○	25	25	150	32	25	36	DN_1506_	CDH6N	DHA1/4-25	SP4DL	HW23.8L HW31.8L	SD43D
	2525-M15-3	○	●	25	25	150	32	25	36	DN_1504_	CDH6N	DHA1/4-25	SP4D	HW23.8L HW31.8L	SD43D
	3232-P15	○	○	32	32	170	40	32	36	DN_1506_	CDH6N	DHA1/4-25	SP4DL	HW23.8L HW31.8L	SD43D
	3232-P15-3	○	○	32	32	170	40	32	36	DN_1504_	CDH6N	DHA1/4-25	SP4D	HW23.8L HW31.8L	SD43D

MDNNN

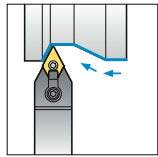

62,5°

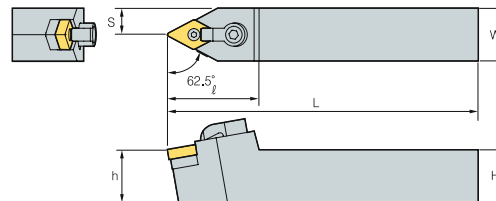

WSP



DN_

Bezeichnung		N	H	W	L	S	h	ℓ	WSP	Klemme	Klemmschraube	Rohrstift	Schlüssel	Zwischenlage
MDNNN	2525-M15	○	25	25	150	12,5	25	41	DN_1506_	CDH8N	DHA5/16-32	SP4DL	HW23.8L HW39.7L	SD43D
	2525-M15-3	●	25	25	150	12,5	25	41	DN_1504_	CDH8N	DHA5/16-32	SP4D	HW23.8L HW39.7L	SD43D



MDQNR/L

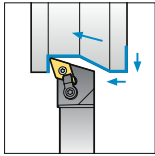

107,5°

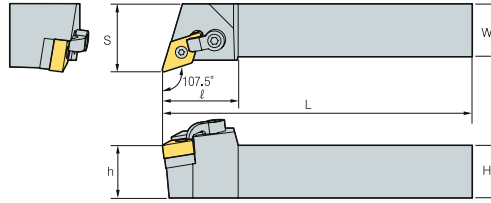

WSP



DN_

Bezeichnung		L	R	H	W	L	S	h	ℓ	WSP	Klemme	Klemmschraube	Rohrstift	Schlüssel	Zwischenlage
MDQNR/L	2525-M15	●	●	25	25	150	32	25	36	DN_1506_	CDH6N	DHA1/4-25	SP4DL	HW23.8L HW31.8L	SD43D
	2525-M15-3	●	○	25	25	150	32	25	36	DN_1504_	CDH6N	DHA1/4-25	SP4D	HW23.8L HW31.8L	SD43D
	3232-M15	○	○	32	32	170	40	32	36	DN_1506_	CDH6N	DHA1/4-25	SP4DL	HW23.8L HW31.8L	SD43D
	3232-P15	○	○	32	32	170	40	32	36		CDH6N	DHA1/4-25	SP4DL	HW23.8L HW31.8L	SD43D
	3232-P15-3	○	○	32	32	170	40	32	36	DN_1504_	CDH6N	DHA1/4-25	SP4D	HW23.8L HW31.8L	SD43D

(mm)

MSBNR/L

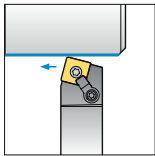

75°

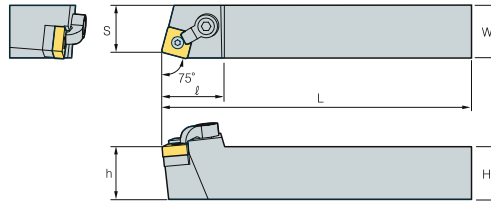

WSP



SN_

Bezeichnung		L	R	H	W	L	S	h	ℓ	WSP	Klemme	Klemmschraube	Rohrstift	Schlüssel	Zwischenlage
MSBNR/L	2020-K12	○	○	20	20	125	17	20	32	SN_1204_	CDH8N1	DHA5/16-32	SP4D	HW23.8L HW39.7L	SS43D
	2525-M12	○	○	25	25	150	22	25	32		CDH8N1	DHA5/16-32	SP4D	HW23.8L HW39.7L	SS43D
	2525-M15	○	○	25	25	150	22	25	35	SN_1506_	CDH8N	DHA5/16-32	SP5D	HW31.8L HW39.7L	SS53D
	3232-P15	○	○	32	32	170	22	32	35		CDH8N	DHA5/16-32	SP5D	HW31.8L HW39.7L	SS53D
	3232-P19	○	○	32	32	170	27	32	40	SN_1906_	CDH8N	DHA5/16-32	SP6D	HW35.7L HW39.7L	SS63D
	4040-S19	○	○	40	40	250	35	40	40		CDH8N	DHA5/16-32	SP6D	HW35.7L HW39.7L	SS63D

(mm)



MSDNN

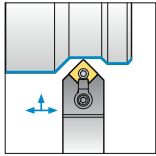

45°

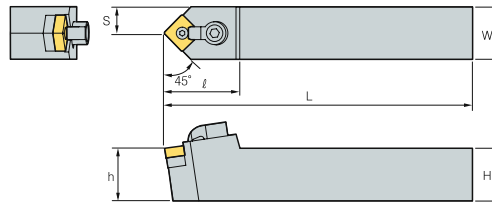

WSP



SN_

(mm)

Bezeichnung	N	H	W	L	S	h	ℓ	WSP	Klemme	Klemmschraube	Rohrstift	Schlüssel	Zwischenlage	
MSDNN	1616-H09	○	16	16	100	8	16	28	SN_0903_	CDH7N	DHA10-32-19	SP3DS	HW19.8L HW23.8L	SS32D
	2020-K09	○	20	20	125	10	20	28		CDH7N	DHA10-32-19	SP3DS	HW19.8L HW23.8L	SS32D
	2020-K12	○	20	20	125	10	20	32	SN_1204_	CDH8N1	DHA5/16-32	SP4D	HW23.8L HW39.7L	SS43D
	2525-M12	○	25	25	150	12,5	25	32		CDH8N1	DHA5/16-32	SP4D	HW23.8L HW39.7L	SS43D
	2525-M15	○	25	25	150	12,5	25	35	SN_1506_	CDH8N	DHA5/16-32	SP5D	HW31.8L HW39.7L	SS53D
	3225-P12	○	32	25	170	12,5	32	32	SN_1204_	CDH8N1	DHA5/16-32	SP4D	HW23.8L HW39.7L	SS43D
	3225-P15	○	32	25	170	12,5	32	35	SN_1506_	CDH8N	DHA5/16-32	SP5D	HW31.8L HW39.7L	SS53D
	3232-P15	○	32	32	170	16	32	35	SN_1906_	CDH8N	DHA5/16-32	SP5D	HW31.8L HW39.7L	SS53D
	3232-P19	○	32	32	170	16	32	42		CDH8N	DHA5/16-32	SP6D	HW35.7L HW39.7L	SS63D
	4040-S15	○	40	40	250	20	40	35	SN_1506_	CDH8N	DHA5/16-32	SP5D	HW31.8L HW39.7L	SS53D
4040-S19	○	40	40	250	20	40	42	SN_1906_	CDH8N	DHA5/16-32	SP6D	HW35.7L HW39.7L	SS63D	

MSKNR/L

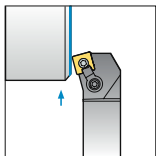

75°

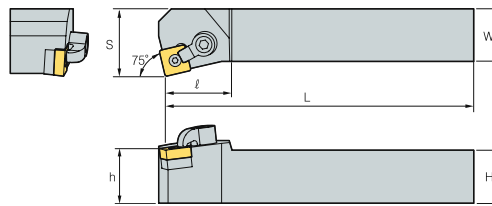

WSP



SN_

(mm)

Bezeichnung	L	R	H	W	L	S	h	ℓ	WSP	Klemme	Klemmschraube	Rohrstift	Schlüssel	Zwischenlage	
MSKNR/L	1616-H09	○	○	16	16	100	20	16	28	SN_0903_	CDH7N	DHA10-32-19	SP3DS	HW19.8L HW23.8L	SS32D
	2020-K09	○	○	20	20	125	22	20	28		CDH7N	DHA10-32-19	SP3DS	HW19.8L HW23.8L	SS32D
	2020-K12	○	○	20	20	125	25	20	32	SN_1204_	CDH8N1	DHA5/16-32	SP4D	HW23.8L HW39.7L	SS43D
	2525-M12	○	○	25	25	150	32	25	32		CDH8N1	DHA5/16-32	SP4D	HW23.8L HW39.7L	SS43D
	2525-M15	○	○	25	25	150	32	25	35	SN_1506_	CDH8N	DHA5/16-32	SP5D	HW31.8L HW39.7L	SS53D
	3225-P12	○	○	32	25	170	32	32	32	SN_1204_	CDH8N1	DHA5/16-32	SP4D	HW23.8L HW39.7L	SS43D
	3232-P15	○	○	32	32	170	40	32	35	SN_1506_	CDH8N	DHA5/16-32	SP5D	HW31.8L HW39.7L	SS53D
	3232-P19	○	○	32	32	170	40	32	40	SN_1906_	CDH8N	DHA5/16-32	SP6D	HW35.7L HW39.7L	SS63D
	4040-S19	○	○	40	40	250	50	40	40	SN_2507_	CDH8N	DHA5/16-32	SP6D	HW35.7L HW39.7L	SS63D
	4040-S25	○	○	40	40	250	50	40	47		CDH8N3	DHA3/8-35	SP8D	HW39.7L HW47.6L	SS84D



MSRNR/L

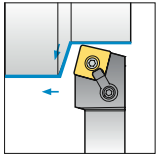

75°

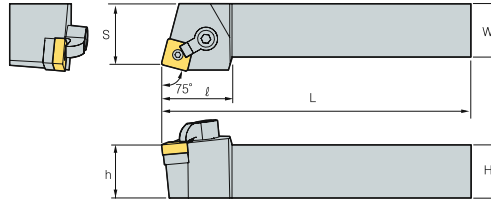

WSP



SN_

Bezeichnung	L	R	H	W	L	S	h	ℓ	WSP	Klemme	Klemmschraube	Rohrstift	Schlüssel	Zwischenlage
MSRNR/L 1616-H09	○	○	16	16	100	17	16	28	SN_0903_	CDH7N	DHA10-32-19	SP3DS	HW19.8L HW23.8L	SS32D
	○	○	20	20	125	22	20	28		CDH7N	DHA10-32-19	SP3DS	HW19.8L HW23.8L	SS32D
2020-K09	○	○	20	20	125	22	20	28	SN_1204_	CDH8N1	DHA5/16-32	SP4D	HW23.8L HW39.7L	SS43D
2020-K12	○	○	20	20	125	22	20	32		CDH8N1	DHA5/16-32	SP4D	HW23.8L HW39.7L	SS43D
2525-M12	○	○	25	25	150	27	25	32	SN_1506_	CDH8N	DHA5/16-32	SP5D	HW31.8L HW39.7L	SS53D
2525-M15	○	○	25	25	150	27	25	35		CDH8N	DHA5/16-32	SP5D	HW31.8L HW39.7L	SS53D
3225-P19	○	○	32	25	170	27	32	40	SN_1906_	CDH8N	DHA5/16-32	SP5D	HW31.8L HW39.7L	SS53D
3232-P15	○	○	32	32	170	35	32	35		CDH8N	DHA5/16-32	SP5D	HW31.8L HW39.7L	SS53D
3232-P19	○	○	32	32	170	35	32	40	SN_1906_	CDH8N	DHA5/16-32	SP6D	HW35.7L HW39.7L	SS63D
4040-S19	○	○	40	40	250	43	40	40		CDH8N	DHA5/16-32	SP6D	HW35.7L HW39.7L	SS63D
4040-S25	○	○	40	40	250	43	40	40	SN_2507_	CDH8N3	DHA3/8-35	SP8D	HW39.7L HW47.6L	SS84D

(mm)

MSSNR/L

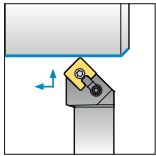

45°

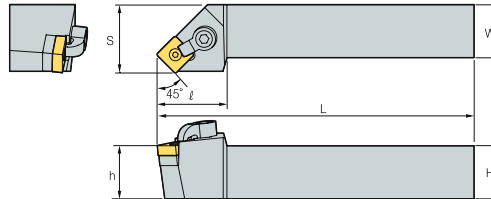

WSP



SN_

Bezeichnung	L	R	H	W	L	S	h	ℓ	WSP	Klemme	Klemmschraube	Rohrstift	Schlüssel	Zwischenlage
MSSNR/L 1616-H09	○	○	16	16	100	20	16	28	SN_0903_	CDH7N	DHA10-32-19	SP3DS	HW19.8L HW23.8L	SS32D
	○	○	20	20	125	25	20	28		CDH7N	DHA10-32-19	SP3DS	HW19.8L HW23.8L	SS32D
2020-K12	○	○	20	20	125	25	20	32	SN_1204_	CDH8N1	DHA5/16-32	SP4D	HW23.8L HW39.7L	SS43D
2525-M12	○	○	25	25	150	32	25	32		CDH8N1	DHA5/16-32	SP4D	HW23.8L HW39.7L	SS43D
2525-M15	○	○	25	25	150	32	25	35	SN_1506_	CDH8N1	DHA5/16-32	SP5D	HW31.8L HW39.7L	SS53D
3232-P15	○	○	32	32	170	40	32	35		CDH8N1	DHA5/16-32	SP5D	HW31.8L HW39.7L	SS53D
3232-P19	○	○	32	32	170	40	32	40	SN_1906_	CDH8N1	DHA5/16-32	SP6D	HW35.7L HW39.7L	SS63D
4040-S19	○	○	40	40	250	50	40	40		CDH8N1	DHA5/16-32	SP6D	HW35.7L HW39.7L	SS63D
4040-S25	○	○	40	40	250	50	40	48	SN_2507_	CDH8N3	DHA3/8-35	SP8D	HW39.7L HW47.6L	SS84D

(mm)



MTENN

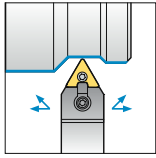

60°

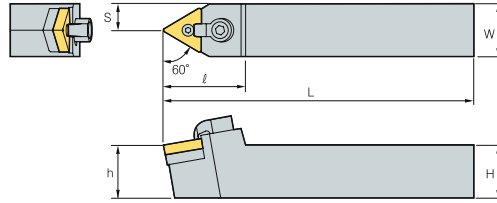

WSP



TN_

Bezeichnung		N	H	W	L	S	h	ℓ	WSP	Klemme	Klemmschraube	Rohrstift	Schlüssel	Zwischenlage
MTENN	2020-K16	○	20	20	125	10	20	32	TN_1604_	CDH7N	DHA10-32-19	SP3D	HW19.8L HW23.8L	ST32D
	2525-M16	○	25	25	150	12,5	25	32	TN_2204_	CDH7N	DHA10-32-19	SP3D	HW19.8L HW23.8L	ST32D
	2525-M22	○	25	25	150	12,5	25	35		CDH8N1	DHA5/16-32	SP4D	HW23.8L HW39.7L	ST43D
	3232-P27	○	32	32	170	16	32	35	TN_2706_	CDH8N1	DHA5/16-32	SP5D	HW31.8L HW39.7L	ST53D
	4040-S33	○	40	40	250	20	40	40	TN_3307_	CDH8N	DHA5/16-32	SP6DL	HW35.7L HW39.7L	ST63D

(mm)

MTFNR/L

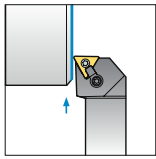

90°

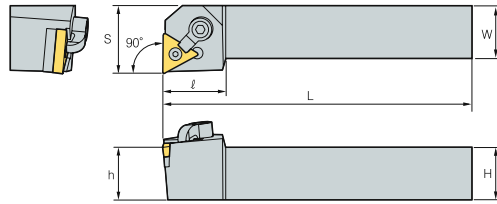

WSP



TN_

Bezeichnung		L	R	H	W	L	S	h	ℓ	WSP	Klemme	Klemmschraube	Rohrstift	Schlüssel	Zwischenlage
MTFNR/L	1616-H16	○	○	16	16	100	20	16	32	TN_1604_	CDH7N	DHA10-32-19	SP3D	HW19.8L HW23.8L	ST32D
	2020-K16	○	○	20	20	125	25	20	32		CDH7N	DHA10-32-19	SP3D	HW19.8L HW23.8L	ST32D
	2525-M16	○	○	25	25	150	32	25	32		CDH7N	DHA10-32-19	SP3D	HW19.8L HW23.8L	ST32D
	2525-M22	○	○	25	25	150	32	25	32	TN_2204_	CDH8N1	DHA5/16-32	SP4D	HW23.8L HW39.7L	ST43D
	3232-P22	○	○	32	32	170	40	32	32		CDH8N1	DHA5/16-32	SP4D	HW23.8L HW39.7L	ST43D
	3232-P27	○	○	32	32	170	40	32	35	TN_2706_	CDH8N1	DHA5/16-32	SP5D	HW31.8L HW39.7L	ST53D
	4040-S22	○	○	40	40	250	50	40	32	TN_2204_	CDH8N1	DHA5/16-32	SP4D	HW23.8L HW39.7L	ST43D
	4040-S27	○	○	40	40	250	50	40	35	TN_2706_	CDH8N1	DHA5/16-32	SP5D	HW31.8L HW39.7L	ST53D
	4040-S33	○	○	40	40	250	50	40	40	TN_3307_	CDH8N	DHA5/16-32	SP6DL	HW35.7L HW39.7L	ST63D

(mm)



MTGNR/L

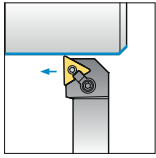

90°

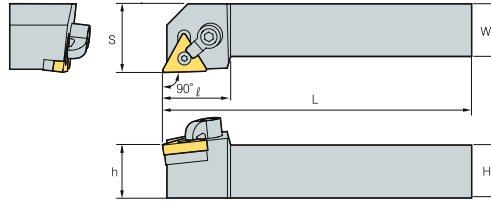

WSP



TN_

Bezeichnung	L	R	H	W	L	S	h	ℓ	WSP	Klemme	Klemmschraube	Rohrstift	Schlüssel	Zwischenlage
MTGNR/L 1616-H16	○	○	16	16	100	20	16	32	TN_1604_	CDH7N	DHA10-32-19	SP3D	HW19.8L HW23.8L	ST32D
	○	○	20	20	125	25	20	32		CDH7N	DHA10-32-19	SP3D	HW19.8L HW23.8L	ST32D
	○	○	25	25	150	32	25	32		CDH7N	DHA10-32-19	SP3D	HW19.8L HW23.8L	ST32D
2525-M16	○	○	25	25	150	32	25	32	TN_2204_	CDH8N1	DHA5/16-32	SP4D	HW23.8L HW39.7L	ST43D
2525-M22	○	○	25	25	150	32	25	32		CDH8N1	DHA5/16-32	SP4D	HW23.8L HW39.7L	ST43D
3232-P22	○	○	32	32	170	40	32	32	TN_2706_	CDH8N1	DHA5/16-32	SP5D	HW31.8L HW39.7L	ST53D
3232-P27	○	○	32	32	170	40	32	35		CDH8N1	DHA5/16-32	SP5D	HW31.8L HW39.7L	ST53D
4040-S27	○	○	40	40	250	50	40	35		CDH8N1	DHA5/16-32	SP5D	HW31.8L HW39.7L	ST53D
4040-S33	○	○	40	40	250	50	40	40	TN_3307_	CDH8N	DHA5/16-32	SP6DL	HW35.7L HW39.7L	ST63D

(mm)

KORLOY

MTJNR/L

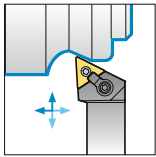

93°

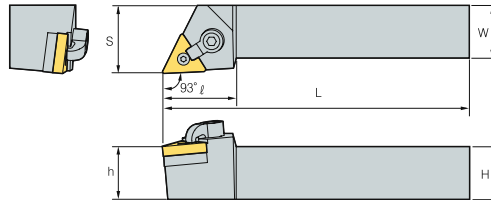

WSP



TN_

Bezeichnung	L	R	H	W	L	S	h	ℓ	WSP	Klemme	Klemmschraube	Rohrstift	Schlüssel	Zwischenlage
MTJNR/L 2020-K16	○	○	20	20	125	25	20	32	TN_1604_	CDH7N	DHA10-32-19	SP3D	HW19.8L HW23.8L	ST32D
	○	●	25	25	150	32	25	32		CDH7N	DHA10-32-19	SP3D	HW19.8L HW23.8L	ST32D
2525-M16	○	○	25	25	150	32	25	32	TN_2204_	CDH8N1	DHA5/16-32	SP4D	HW23.8L HW39.7L	ST43D
2525-M22	○	○	25	25	150	32	25	32		CDH8N1	DHA5/16-32	SP4D	HW23.8L HW39.7L	ST43D
3232-P22	○	○	32	32	170	40	32	32	TN_2706_	CDH8N1	DHA5/16-32	SP5D	HW31.8L HW39.7L	ST53D
3232-P27	○	○	32	32	170	40	32	35		CDH8N1	DHA5/16-32	SP5D	HW31.8L HW39.7L	ST53D
4040-S27	○	○	40	40	250	50	40	35		CDH8N1	DHA5/16-32	SP5D	HW31.8L HW39.7L	ST53D
4040-S33	○	○	40	40	250	50	40	40	TN_3307_	CDH8N	DHA5/16-32	SP6DL	HW35.7L HW39.7L	ST63D

(mm)



MVJNR/L

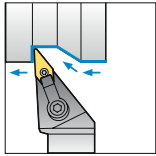

93°

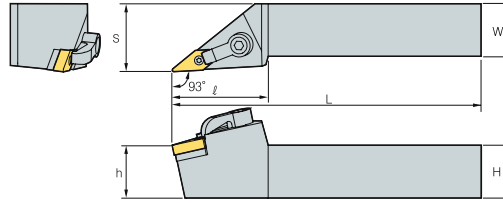

WSP



VN_

Bezeichnung		L	R	H	W	L	S	h	ℓ	WSP	Klemme	Klemmschraube	Rohrstift	Schlüssel	Zwischenlage
MVJNR/L	2020-K16	●	●	20	20	125	25	20	37	VN_1604_	CDH8N2	DHA5/16-32	SP3D	HW19.8L HW39.7L	SV32D
	2525-M16	●	●	25	25	150	32	25	37		CDH8N2	DHA5/16-32	SP3D	HW19.8L HW39.7L	SV32D
	2525-M22	○	○	25	25	150	32	25	50	VN_2204_	CDH8N2	DHA5/16-32	SP4D	HW23.8L HW39.7L	SV43D
	3232-P16	○	○	32	32	170	40	32	37	VN_1604_	CDH8N2	DHA5/16-32	SP3D	HW19.8L HW39.7L	SV32D
	3232-P22	○	○	32	32	170	40	32	50	VN_2204_	CDH8N2	DHA5/16-32	SP4D	HW23.8L HW39.7L	SV43D
	4040-S22	○	○	40	40	250	50	40	50		CDH8N2	DHA5/16-32	SP4D	HW23.8L HW39.7L	SV43D

(mm)

MVQNR/L

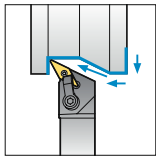

117,5°

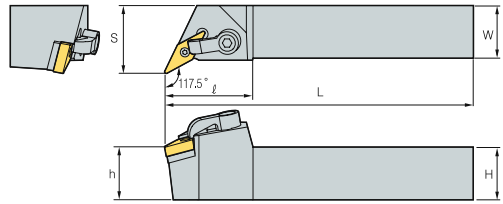

WSP



VN_

Bezeichnung		L	R	H	W	L	S	h	ℓ	WSP	Klemme	Klemmschraube	Rohrstift	Schlüssel	Zwischenlage
MVQNR/L	2020-K16	●	●	20	20	125	25	20	42	VN_1604_	CDH8N2	DHA5/16-32	SP3D	HW19.8L HW39.7L	SV32D
	2525-M16	●	●	25	25	150	32	25	42		CDH8N2	DHA5/16-32	SP3D	HW19.8L HW39.7L	SV32D
	3232-P16	○	○	32	32	170	40	32	37		CDH8N2	DHA5/16-32	SP3D	HW19.8L HW39.7L	SV32D

(mm)



MVVNN

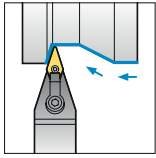

72,5°

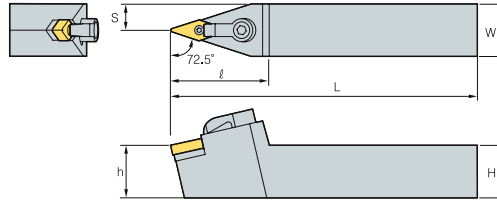

WSP



VN_

Bezeichnung		N	H	W	L	S	h	ℓ	WSP	Klemme	Klemmschraube	Rohrstift	Schlüssel	Zwischenlage
MVVNN	2020-K16	●	20	20	125	25	20	42	VN_1604_	CDH8N2	DHA5/16-32	SP3D	HW19.8L HW39.7L	SV32D
	2525-M16	●	25	25	150	32	25	42		CDH8N2	DHA5/16-32	SP3D	HW19.8L HW39.7L	SV32D

(mm)

MWLNR/L

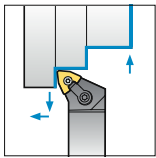

95°

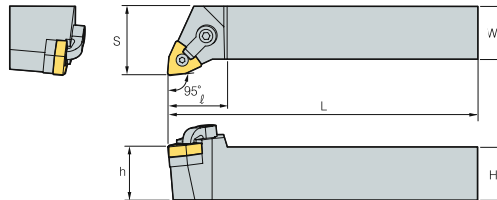

WSP



WN_

Bezeichnung		L	R	H	W	L	S	h	ℓ	WSP	Klemme	Klemmschraube	Rohrstift	Schlüssel	Zwischenlage
MWLNR/L	2020-K06	○	○	20	20	125	25	20	32	WN_0604_	CDH7N	DHA10-32-19	SP3D	HW19.8L HW23.8L	SW32D
	2020-K08	○	●	20	20	125	25	20	32	WN_0804_	CDH6N	DHA1/4-21	SP4D	HW23.8L HW31.8L	SW43D
	2525-M06	○	○	25	25	150	32	25	32	WN_0604_	CDH7N	DHA10-32-19	SP3D	HW19.8L HW23.8L	SW32D
	2525-M08	●	●	25	25	150	32	25	32	WN_0804_	CDH6N	DHA1/4-21	SP4D	HW23.8L HW31.8L	SW43D
	3232-P06	○	○	32	32	170	40	32	32	WN_0604_	CDH7N	DHA10-32-19	SP3D	HW19.8L HW23.8L	SW32D
	3232-P08	○	○	32	32	170	40	32	32	WN_0804_	CDH6N	DHA1/4-21	SP4D	HW23.8L HW31.8L	SW43D
	3232-P13		○	32	32	170		32		WN_1306_	CDH8N	DHA5/16-32	SP6D	HW35.7L HW39.7L	SW63D
	4040-P13	○	○	40	40	170		40			CDH8N	DHA5/16-32	SP6D	HW35.7L HW39.7L	SW63D

(mm)



SCACR/L

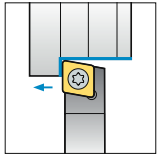

90°

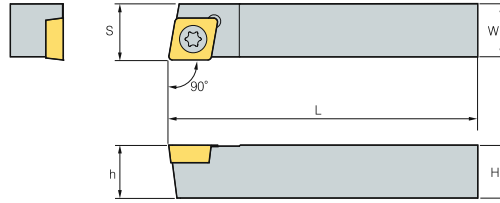

WSP



CC_

Bezeichnung		L	R	H	W	L	S	h	WSP	Schlüssel	Schraube
SCACR/L	1010-E06	▲	○	10	10	70	10,5	10	CC__0602__	TW07P	FTKA02565
	1212-F09	▲	▲	12	12	80	12,5	12	CC__09T3__	TW15P	FTKA03508

(mm)

SCLCR/L

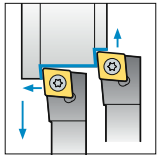

95°

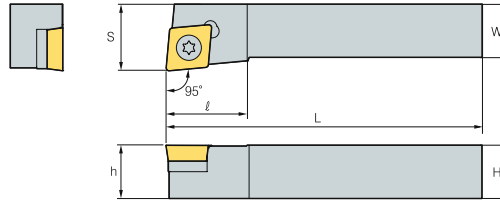

WSP



CC_

Bezeichnung		L	R	H	W	L	S	h	ℓ	WSP	Lagenschraube	Schlüssel	Schraube	Zwischenlage
SCLCR/L	0808-D06	▲	▲	8	8	60	10	8	10	CC__0602__	-	TW07P	FTKA02565	-
	1010-E06	▲	▲	10	10	70	16	10	10	-	-	TW07P	FTKA02565	-
	1212-F09	▲	▲	12	12	80	20	12	16	CC__09T3__	-	TW15P	FTGA03508	-
	1616-H09	▲	▲	16	16	100	20	16	16	-	-	TW15P	FTGA03508	-
	2020-H09	▲	▲	20	20	100	25	20	16	-	-	TW15P	FTGA03508	-
	2020-K09	▲	▲	20	20	125	25	20	16	-	-	TW15P	FTGA03508	-
	2020-K12	▲	▲	20	20	125	25	20	25	CC__1204__	SHXN0610F	TW15P HW40L	FTGA0411F	SC42S
	2525-M09		▲	25	25	150	32	25	26	CC__09T3__	-	TW15P	FTGA03508	-
	2525-M12	▲	▲	25	25	150	32	25	26	CC__1204__	SHXN0610F	TW15P HW40L	FTGA0411F	SC42S

(mm)



SDACR/L

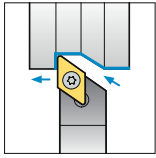

90°

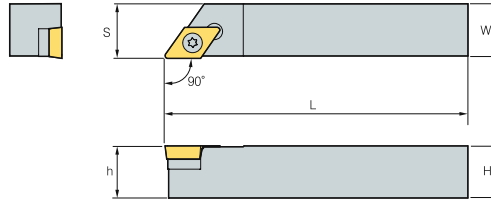

WSP



DC_

Bezeichnung		L	R	H	W	L	S	h	WSP	Lagenschraube	Schlüssel	Schraube	Zwischenlage
SDACR/L	1010-E07	▲	▲	10	10	70	10,5	10	DC__0702__	-	TW07P	FTKA02565	-
	1212-C11	○		12	12	50	12,5	12	DC__11T3__	SHXN0509F	TW15P HW35L	FTGA03512	SD32S
	1212-F11	▲	▲	12	12	80	12,5	12		-	TW15P	FTKA03508	-
	1212-M11	▲	▲	12	12	150	12,5	12		-	TW15P	FTKA03508	-
	1616-H11	▲	▲	16	16	100	16,5	16		SHXN0509F	TW15P HW35L	FTGA03512	SD32S
	2020-H11	▲	▲	20	20	100	20,5	20		SHXN0509F	TW15P HW35L	FTGA03512	SD32S
	2020-K11	○		20	20	125	20,5	20		SHXN0509F	TW15P HW35L	FTGA03512	SD32S

(mm)



SDJCR/L

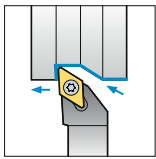

93°

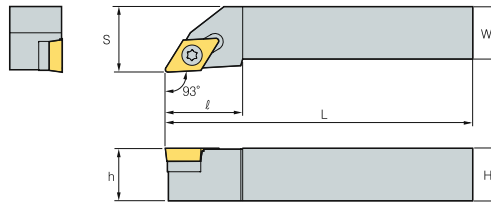

WSP



DC_

Bezeichnung		L	R	H	W	L	S	h	ℓ	WSP	Lagenschraube	Schlüssel	Schraube	Zwischenlage
SDJCR/L	1010-E07	▲	▲	10	10	70	10	15	15	DC__0702__	-	TW07P	FTKA02565	-
	1010-F07	▲		10	10	80	12	10	10		-	TW07P	FTKA02565	-
	1212-F07	▲	▲	12	12	80	12	15	15		-	TW07P	FTKA02565	-
	1212-F11	▲	▲	12	12	80	12	15	15	DC__11T3__	SHXN0509F	TW15P HW35L	FTGA03512	SD32S
	1212-M11	○	○	12	12	150	80	15	15		SHXN0509F	TW15P HW35L	FTGA03512	SD32S
	1616-H07	▲	▲	16	16	100	16	18	18	DC__0702__	-	TW07P	FTKA02565	-
	1616-H11	▲	▲	16	16	100	16	24	24	DC__11T3__	SHXN0509F	TW15P HW35L	FTGA03512	SD32S
	2020-K07	▲	▲	20	20	125	20	15	15	DC__0702__	-	TW07P	FTKA02565	-
	2020-K11	▲	▲	20	20	125	20	24	24	DC__11T3__	SHXN0509F	TW15P HW35L	FTGA03512	SD32S
	2525-M11	▲	▲	25	25	150	25	29	29		SHXN0509F	TW15P HW35L	FTGA03512	SD32S

(mm)



SDNCN

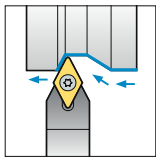

62,5°

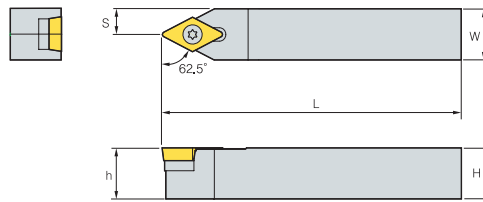

WSP



DC_

Bezeichnung		N	H	W	L	S	h	WSP	Lagenschraube	Schlüssel	Schraube	Zwischenlage
SDNCN	1010-E07	▲	10	10	70	5	10	DC_0702_	-	TW07P	FTKA02565	-
	1212-F07	▲	12	12	80	6	12		-	TW07P	FTKA02565	-
	1212-H11	▲	12	12	100	6	12	DC_11T3_	-	TW15P	FTGA03508	-
	1212-M11	▲	12	12	150	6	12		-	TW15P	FTGA03508	-
	1616-H11	▲	16	16	100	8	16		SHXN0509F	TW15P HW35L	FTGA03512	SD32S
	2020-K11	▲	20	20	125	10	20		SHXN0509F	TW15P HW35L	FTGA03512	SD32S
	2525-M11	▲	25	25	150	12,5	25		SHXN0509F	TW15P HW35L	FTGA03512	SD32S

(mm)

SRDCN

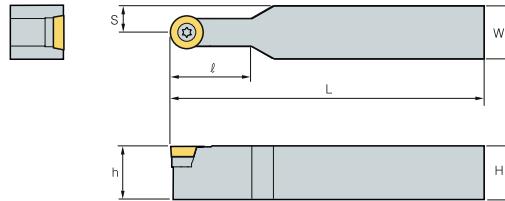
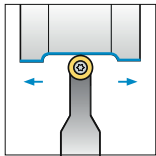

WSP



RCGT

Bezeichnung		N	H	W	L	S	h	ℓ	WSP	Lagenschraube	Schlüssel	Schraube	Zwischenlage
SRDCN	1010-E06	▲	10	10	70	5	10	10	RCGT0602M0	-	TW07P	FTKA02565	-
	1212-F06	▲	12	12	80	6	12	12		-	TW07P	FTKA02565	-
	1616-H06	▲	16	16	100	8	16	12		-	TW07P	FTKA02565	-
	1616-H08	▲	16	16	100	8	16	16	RCGT0803M0	-	TW09P	FTNA0307	-
	1616-H10	▲	16	16	100	8	16	25	RCGT1003M0	SHXN0509F	TW15P HW35L	FTKA03511A	SR10S
	2020-H10	○	20	20	100	10	20	25		SHXN0509F	TW15P HW35L	FTKA03511A	SR10S
	2020-K06	▲	20	20	125	10	20	24	RCGT0602M0	-	TW07P	FTKA02565	-
	2020-K08	▲	20	20	125	10	20	20	RCGT0803M0	-	TW09P	FTNA0307	-
	2020-K10	▲	20	20	125	10	20	25	RCGT1003M0	SHXN0509F	TW15P HW35L	FTKA03511A	SR10S
	2020-K12	▲	20	20	125	10	20	28	RCGT1204M0	SHXN0509F	TW15P HW35L	FTGA03512	SR12S
	2525-M06	▲	25	25	150	12,5	25	20	RCGT0602M0	-	TW07P	FTKA02565	-
	2525-M08	▲	25	25	150	12,5	25	20	RCGT0803M0	-	TW09P	FTNA0307	-
	2525-M10	▲	25	25	150	12,5	25	25	RCGT1003M0	SHXN0509F	TW15P HW35L	FTKA03511A	SR10S
	2525-M12	▲	25	25	150	12,5	25	28	RCGT1204M0	SHXN0509F	TW15P HW35L	FTGA03512	SR12S

(mm)



SRGCR/L

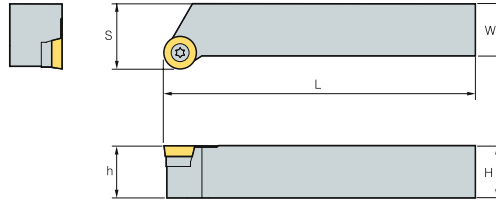
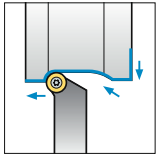

(mm)

Bezeichnung		L	R	H	W	L	S	h	WSP	Lagenschraube	Schlüssel	Schraube	Zwischenlage
SRGCR/L	1010-E06	○	○	10	10	70	12	10	RCGT0602M0	-	TW07P	FTKA02565	-
	1212-F06	○	▲	12	12	80	16	12		-	TW07P	FTKA02565	-
	1616-H06	○	▲	16	16	100	20	16		-	TW07P	FTKA02565	-
	1616-H08	○	○	16	16	100	20	16	RCGT0803M0	-	TW09P	FTNA0307	-
	1616-H10	○	▲	16	16	100	20	16	RCGT1003M0	SHXN0509F	TW15P HW35L	FTKA03511A	SR10S
	2020-K06		○	20	20	125	25	20	RCGT0602M0	-	TW07P	FTKA02565	-
	2020-K08	○	▲	20	20	125	25	20	RCGT0803M0	-	TW09P	FTNA0307	-
	2020-K10	▲	●	20	20	125	25	20	RCGT1003M0	SHXN0509F	TW15P HW35L	FTKA03511A	SR10S
	2020-K12	▲	●	20	20	125	25	20	RCGT1204M0	SHXN0509F	TW15P HW35L	FTGA03512	SR12S
	2525-M06		▲	25	25	150	32	25	RCGT0602M0	-	TW07P	FTKA02565	-
	2525-M08	○	▲	25	25	150	32	25	RCGT0803M0	-	TW09P	FTNA0307	-
	2525-M10	○	▲	25	25	150	32	25	RCGT1003M0	SHXN0509F	TW15P HW35L	FTKA03511A	SR10S
2525-M12	▲	▲	25	25	150	32	25	RCGT1204M0	SHXN0509F	TW15P HW35L	FTGA03512	SR12S	



SSBCR/L

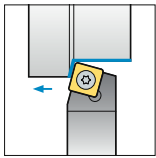

75°

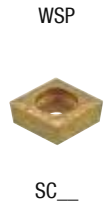
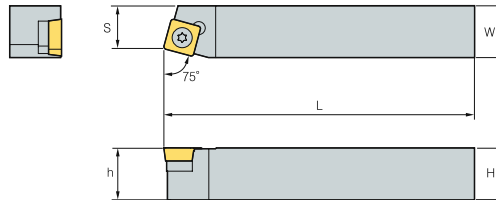

(mm)

Bezeichnung		L	R	H	W	L	S	h	WSP	Lagenschraube	Schlüssel	Schraube	Zwischenlage
SSBCR/L	1212-F09	○	▲	12	12	80	11	12	SC_09T3_	-	TW15P	FTGA03508	-
	1212-H09		○	12	12	100	11	12		SHXN0509F	TW15P HW35L	FTGA03512	SS32S
	1616-H09	▲	●	16	16	100	13	16		SHXN0509F	TW15P HW35L	FTGA03512	SS32S
	2020-K12	▲	▲	20	20	125	17	20	SC_1204_	SHXN0610F	TW15P HW40L	FTGA0411F	SS42S



SSDCN

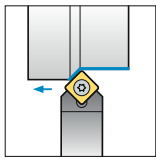

45°

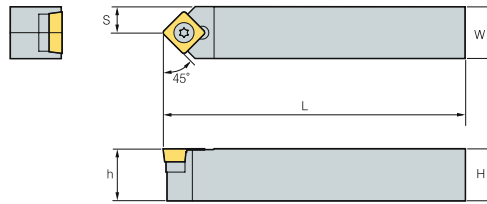

WSP

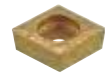

SC_

(mm)

Bezeichnung		N	H	W	L	S	h	WSP	Lagenschraube	Schlüssel	Schraube	Zwischenlage
SSDCN	1212-F09	▲	12	12	80	6	12	SC__09T3__	-	TW15P	FTGA03508	-
	1616-H09	▲	16	16	100	8	16		SHXN0509F	TW15P HW35L	FTGA03512	SS32S

SSKCR/L

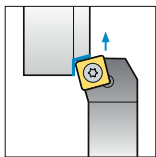

75°

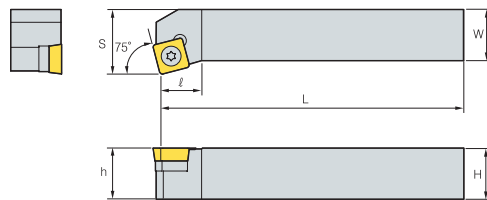

WSP

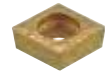

SC_

(mm)

Bezeichnung		L	R	H	W	L	S	h	ℓ	WSP	Lagenschraube	Schlüssel	Schraube	Zwischenlage
SSKCR/L	1616-H09	○	○	16	16	100	20	16	13	SC__09T3__	SHXN0509F	TW15P HW35L	FTGA03512	SS32S

SSSCR/L

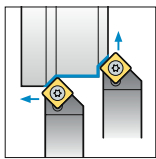

45°

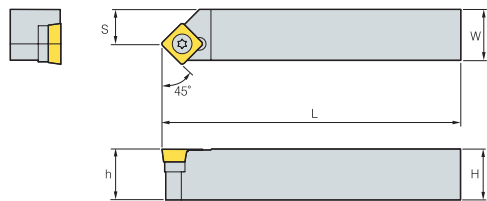

WSP

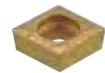

SC_

(mm)

Bezeichnung		L	R	H	W	L	S	h	WSP	Lagenschraube	Schlüssel	Schraube	Zwischenlage
SSSCR/L	1616-H09	▲	▲	16	16	100	17	16	SC__09T3__	SHXN0509F	TW15P HW35L	FTGA03512	SS32S
	2020-K09	▲	▲	20	20	125	25	20		SHXN0509F	TW15P HW35L	FTGA03512	SS32S
	2020-K12	▲	▲	20	20	125	21	20	SC__1204__	SHXN0610F	TW15P HW40L	FTGA0411F	SS42S
	2525-M12	▲	▲	25	25	150	26	25		SHXN0610F	TW15P HW35L	FTGA0411F	SS42S



STACR/L

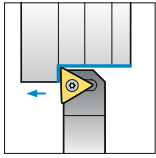

90°

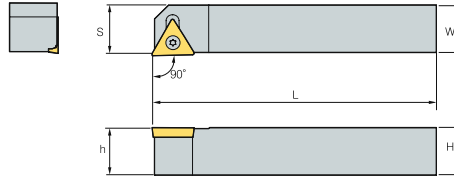

WSP



TC_

Bezeichnung		L	R	H	W	L	S	h	WSP	Schlüssel	Schraube
STACR/L	1010-E09	○	○	10	10	70	10,5	10	TC__0902__	TW06P	FTKA02206
	1212-F11	▲	●	12	12	80	12,5	12	TC__1102__	TW07P	FTKA02565

(mm)

STFCR/L

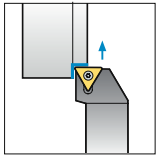

90°

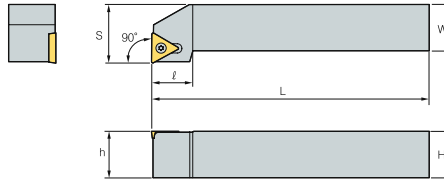

WSP



TC_

Bezeichnung		L	R	H	W	L	S	h	ℓ	WSP	Lagenschraube	Schlüssel	Schraube	Zwischenlage
STFCR/L	1010-E09	▲	▲	10	10	70	12	10	10	TC__0902__	-	TW06P	FTKA02206	-
	1212-F11	○	▲	12	12	80	16	12	14	TC__1102__	-	TW07P	FTKA02565	-
	1616-H11	▲	▲	16	16	100	20	16	14	-	-	TW07P	FTKA02565	-
	1616-H16	▲	▲	16	16	100	20	16	19	TC__16T3__	SHXN0509F	TW15P HW35L	FTGA03512	ST32S
	2020-K16	▲	▲	20	20	125	25	20	19	-	SHXN0509F	TW15P HW35L	FTGA03512	ST32S
	2525-M16	●	●	25	25	150	32	25	25	-	SHXN0509F	TW15P HW35L	FTGA03512	ST32S

(mm)



STGCR/L

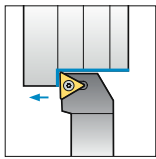

90°

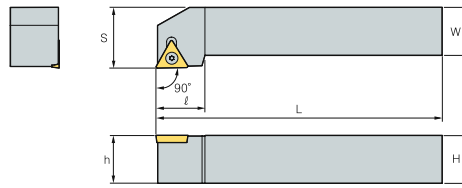

WSP



TC_

Bezeichnung		L	R	H	W	L	S	h	ℓ	WSP	Lagenschraube	Schlüssel	Schraube	Zwischenlage
STGCR/L	0808-D09	○	○	8	8	60	10	8	11	TC__0902__	-	TW06P	FTKA02206	-
	1010-E09	○	▲	10	10	70	12	10	11		-	TW06P	FTKA02206	-
	1212-F11	●	▲	12	12	80	16	12	14	TC__1102__	-	TW07P	FTKA02565	-
	1616-H11	▲	▲	16	16	100	20	16	16		-	TW07P	FTKA02565	-
	1616-H16	●	▲	16	16	100	20	16	21	TC__16T3__	SHXN0509F	TW15P HW35L	FTGA03512	ST32S
	2020-K16	▲	▲	20	20	125	25	20	21		SHXN0509F	TW15P HW35L	FTGA03512	ST32S
	2525-M16	▲	▲	25	25	150	32	25	21		SHXN0509F	TW15P HW35L	FTGA03512	ST32S

(mm)

STTCR/L

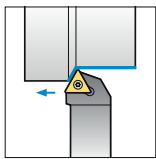

60°

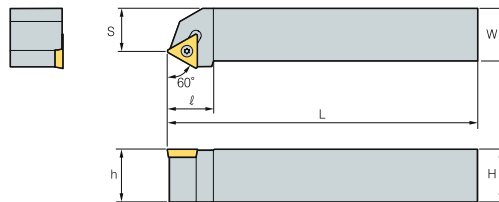

WSP



TC_

Bezeichnung		L	R	H	W	L	S	h	ℓ	WSP	Lagenschraube	Schlüssel	Schraube	Zwischenlage
STTCR/L	1616-H11	○	▲	16	16	100	13	16	14	TC__1102__	-	TW07P	FTKA02565	-
	1616-H16	○	○	16	16	100	13	16	19	TC__16T3__	SHXN0509F	TW15P HW35L	FTGA03512	ST32S
	2020-K16	○	▲	20	20	125	17	20	19		SHXN0509F	TW15P HW35L	FTGA03512	ST32S
	2525-M11		▲	25	25	150	22	25	20	TC__1102__	-	TW07P	FTKA02565	-

(mm)



SVABR/L

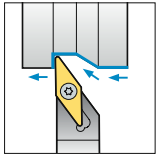

90°

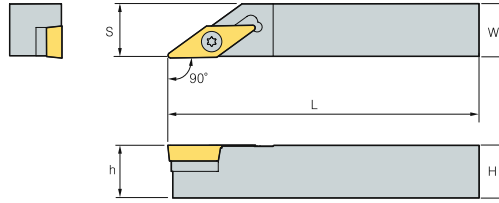

WSP



VB_

(mm)

Bezeichnung		L	R	H	W	L	S	h	WSP	Lagenschraube	Schlüssel	Schraube	Zwischenlage
SVABR/L	1616-H16	▲	▲	16	16	100	16,5	16	VB__1604__	SHXN0509F	TW15P HW35L	FTGA03512	SV32S
	1616-K16	○	○	16	16	125	16,5	16		SHXN0509F	TW15P HW35L	FTGA03512	SV32S
	2020-K16	▲	▲	20	20	125	20,5	20		SHXN0509F	TW15P HW35L	FTGA03512	SV32S

SVHBR/L

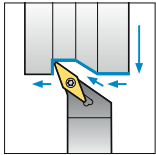

107,5°

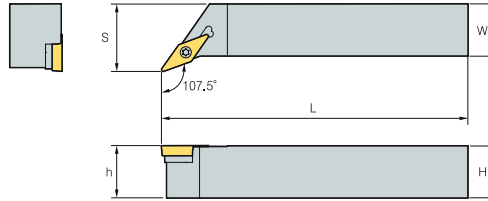

WSP



VB_

(mm)

Bezeichnung		L	R	H	W	L	S	h	WSP	Lagenschraube	Schlüssel	Schraube	Zwischenlage
SVHBR/L	2020-K16	▲		20	20	125	25	20	VB__1604__	SHXN0509F	TW15P HW35L	FTGA03512	SV32S
	2525-M16	▲	▲	25	25	150	32	25		SHXN0509F	TW15P HW35L	FTGA03512	SV32S
	3225-P16	▲	▲	32	25	170	32	32		SHXN0509F	TW15P HW35L	FTGA03512	SV32S



SVJBR/L

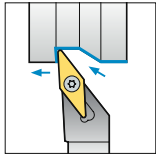

93°

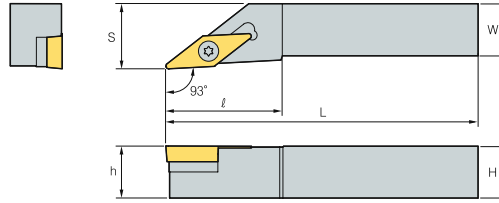

WSP



VB_

Bezeichnung		L	R	H	W	L	S	h	ℓ	WSP	Lagenschraube	Schlüssel	Schraube	Zwischenlage
SVJBR/L	1212-F11	▲	▲	12	12	80	16	12	27	VB_1102_	-	TW07P	FTKA02565	-
	1616-H11	▲	▲	16	16	100	20	16	27		-	TW07P	FTKA02565	-
	1616-H11-2		○	16	16	100	20	16	27	VB_1103_	-	TW07P	FTKA02565	-
	1616-H16	▲	▲	16	16	100	20	16	36	VB_1604_	SHXN0509F	TW15P HW35L	FTGA03512	SV32S
	2020-K11	▲	▲	20	20	125	25	20	27	VB_1102_	-	TW07P	FTKA02565	-
	2020-K11-2	○	○	20	20	125	25	20	27	VB_1103_	-	TW07P	FTKA02565	-
	2020-K16	▲	▲	20	20	125	25	20	41	VB_1604_	SHXN0509F	TW15P HW35L	FTGA03512	SV32S
	2525-M11	○	▲	25	25	150	32	25	35	VB_1102_	-	TW07P	FTKA02565	-
	2525-M16	▲	▲	25	25	150	32	25	41	VB_1604_	SHXN0509F	TW15P HW35L	FTGA03512	SV32S
	3225-P16	▲	▲	32	25	170	32	32	55		SHXN0509F	TW15P HW35L	FTGA03512	SV32S
3232-P16	○	▲	32	32	170	32	32	55		SHXN0509F	TW15P HW35L	FTGA03512	SV32S	

(mm)

SVJCR/L

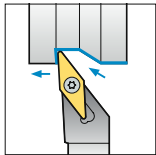

93°

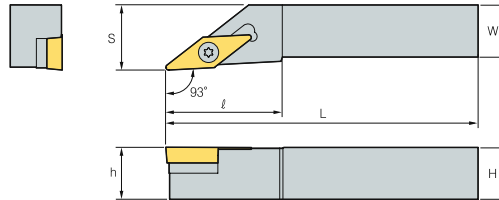

WSP



VC_

Bezeichnung		L	R	H	W	L	S	h	ℓ	WSP	Lagenschraube	Schlüssel	Schraube	Zwischenlage
SVJCR/L	1212-F11	▲	▲	12	12	80	16	12	25	VC_1103_	-	TW07P	FTKA02565	-
	1212-F13	▲	▲	12	12	80	16	12	32	VC_1303_	-	TW09P	FTKA0307	-
	1616-H11	▲	▲	16	16	100	20	16	25	VC_1103_	-	TW07P	FTKA02565	-
	1616-H13	▲	○	16	16	100	20	16	32	VC_1303_	-	TW09P	FTKA0307	-
	1616-H16	▲	▲	16	16	100	20	16	40	VC_1604_	SHXN0509F	TW15P HW35L	FTGA03512	SV32S
	2020-K11	▲	▲	20	20	125	25	20	25	VC_1103_	-	TW07P	FTKA02565	-
	2020-K13	▲	▲	20	20	125	25	20	32	VC_1303_	-	TW09P	FTKA0307	-
	2020-K16	▲	▲	20	20	125	25	20	40	VC_1604_	SHXN0509F	TW15P HW35L	FTGA03512	SV32S
	2525-M11	▲	▲	25	25	150	32	25	42	VC_1103_	-	TW07P	FTKA02565	-
	2525-M13	▲	○	25	25	150	32	25	43	VC_1303_	-	TW09P	FTKA0307	-
	2525-M16	▲	▲	25	25	150	32	25	40	VC_1604_	SHXN0509F	TW15P HW35L	FTGA03512	SV32S

(mm)



SVVBN

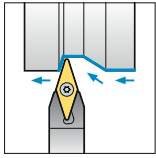

72,5°

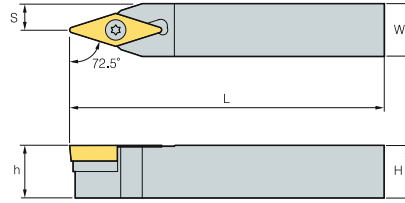

WSP



VB_

(mm)

Bezeichnung		N	H	W	L	S	h	WSP	Lagenschraube	Schlüssel	Schraube	Zwischenlage
SVVBN	1212-F11	▲	12	12	80	6	12	VB_1102_	-	TW07P	FTKA02565	-
	1616-H11	▲	16	16	100	8	16		-	TW07P	FTKA02565	-
	1616-H16	▲	16	16	100	8	16	VB_1604_	SHXN0509F	TW15P HW35L	FTGA03512	SV32S
	2020-K11	▲	20	20	125	10	20	VB_1102_	-	TW07P	FTKA02565	-
	2020-K16	▲	20	20	125	10	20	VB_1604_	SHXN0509F	TW15P HW35L	FTGA03512	SV32S
	2525-M16	▲	25	25	150	12,5	25		SHXN0509F	TW15P HW35L	FTGA03512	SV32S
	3225-P16	▲	32	25	170	12,5	32		SHXN0509F	TW15P HW35L	FTGA03512	SV32S
	3232-P16	▲	32	32	170	12,5	32		SHXN0509F	TW15P HW35L	FTGA03512	SV32S



SVVCN

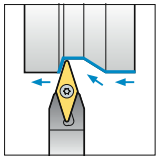

72,5°

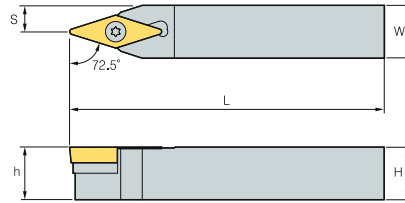

WSP



VC_

(mm)

Bezeichnung		N	H	W	L	S	h	WSP	Lagenschraube	Schlüssel	Schraube	Zwischenlage
SVVCN	1212-F11	▲	12	12	80	6	12	VC_1103_	-	TW07P	FTKA02565	-
	1212-F13	▲	12	12	80	6	12	VC_1303_	-	TW09P	FTNA0307	-
	1616-H11	▲	16	16	100	8	16	VC_1103_	-	TW07P	FTKA02565	-
	1616-H13	○	16	16	100	8	16	VC_1303_	-	TW09P	FTNA0307	-
	1616-H16	○	16	16	100	8	16	VC_1604_	SHXN0509F	TW15P HW35L	FTGA03512	SV32S
	2020-K11	▲	20	20	125	10	20	VC_1103_	-	TW07P	FTKA02565	-
	2020-K13	▲	20	20	125	10	20	VC_1303_	-	TW09P	FTNA0307	-
	2020-K16	▲	20	20	125	10	20	VC_1604_	SHXN0509F	TW15P HW35L	FTGA03512	SV32S
	2525-M16	▲	25	25	150	12,5	25		SHXN0509F	TW15P HW35L	FTGA03512	SV32S



SWACR/L

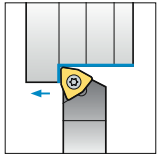

90°

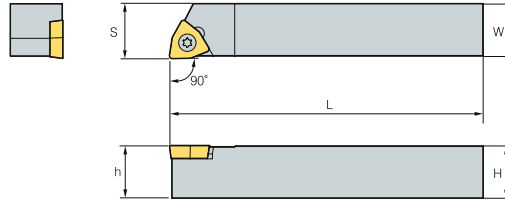

WSP



WC_

Bezeichnung		L	R	H	W	L	S	h	WSP	Schlüssel	Schraube
SWACR/L	1010-E04	○	○	10	10	70	10,1	10	WC__0402__	TW07P	FTKA02565
	1212-F04	○	○	12	12	80	12,1	12		TW07P	FTKA02565
	1616-H06	○	○	16	16	100	16,1	16	WC__06T3__	TW15P	FTGA03508
	2020-K08	○	○	20	20	125	20,1	20	WC__0804__	TW15P	FTGA0411F

(mm)



CCLNR/L

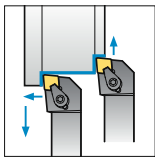

95°

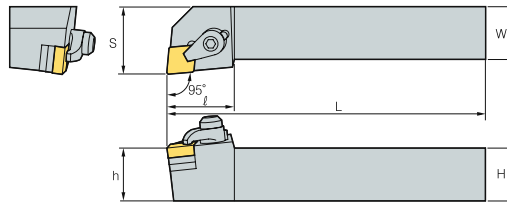

WSP

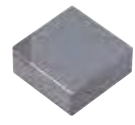

CN_

(mm)

Bezeichnung	L	R	H	W	L	S	h	ℓ	WSP	Feder	Klemme	Schlüssel	Schraube	Zwischenlage
CCLNR/L 2525-M12C	○	●	25	25	150	32	25	32	CN_N1204_ CN_N1207_	SR3	CH6R3	HW20L HW40L	SHX0310 MHX0630	SC42CC

CRDNN

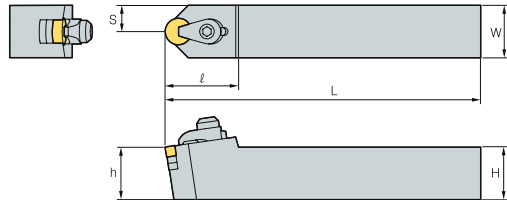
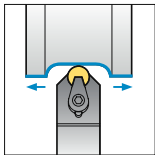

WSP



RN_

(mm)

Bezeichnung	N	H	W	L	S	h	ℓ	WSP	Feder	Klemme	Schlüssel	Schraube	Zwischenlage
CRDNN 2525-M12C	●	25	25	150	12,5	25	35	RN_N1204_ RN_N1207_	SR3	CH6R3	HW20L HW40L	SHX0310 MHX0630	SR42CC
3225-P12C	○	32	25	170	16	32	35		SR3	CH6R3	HW20L HW40L	SHX0310 MHX0630	SR42CC

CRGNR/L

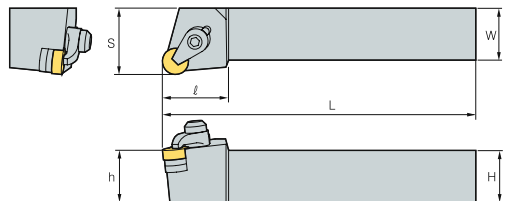
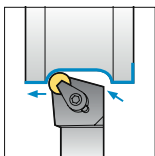

WSP



RN_

(mm)

Bezeichnung	L	R	H	W	L	S	h	ℓ	WSP	Feder	Klemme	Schlüssel	Schraube	Zwischenlage
CRGNR/L 2525-M12C	○	●	25	25	150	32	25	32	RN_N1204_ RN_N1207_	SR3	CH6R3	HW20L HW40L	SHX0310 MHX0630	SR42CC
3225-P12C	○	○	32	25	170	32	32	35		SR3	CH6R3	HW20L HW40L	SHX0310 MHX0630	SR42CC



CSDNN

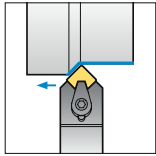

45°

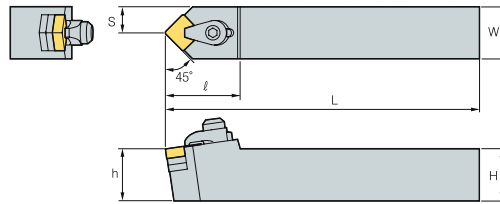

WSP



SN_

(mm)

Bezeichnung		N	H	W	L	S	h	ℓ	WSP	Feder	Klemme	Schlüssel	Schraube	Zwischenlage
CSDNN	2525-M12C	●	25	25	125	12,5	25	35	SN_N1204_ SN_N1207_	SR3	CH6R3	HW20L HW40L	SHX0310 MHX0630	SS42CC
	3225-P12C	○	32	25	170	16	32	35		SR3	CH6R3	HW20L HW40L	SHX0310 MHX0630	SS42CC

CSKNR/L

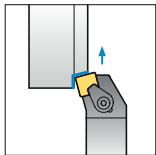

75°

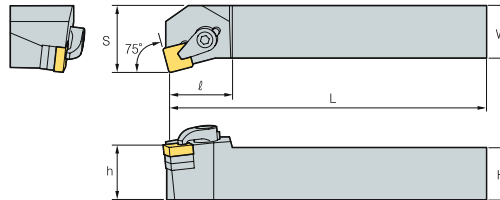

WSP



SN_

(mm)

Bezeichnung		L	R	H	W	L	S	h	ℓ	WSP	Feder	Klemme	Schlüssel	Schraube	Zwischenlage
CSKNR/L	2020-K12C		○	20	20	125	27	20	28	SN_N1204_ SN_N1207_	SR3	CH6R3	HW20L HW40L	SHX0310 MHX0630	SS42CC
	2525-M12C		○ ●	25	25	150	32	25	28		SR3	CH6R3	HW20L HW40L	SHX0310 MHX0630	SS42CC
	3225-P12C		○	32	25	170	32	32	34		SR3	CH6R3	HW20L HW40L	SHX0310 MHX0630	SS42CC

CTFNR/L

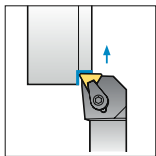

90°

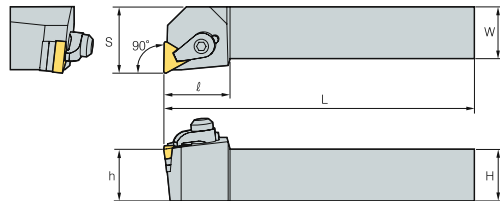

WSP



TP_, TN_

(mm)

Bezeichnung		L	R	H	W	L	S	h	ℓ	WSP	Feder	Klemme	Schlüssel	Schraube	Zwischenlage	
CTFNR/L	2020-K16C		○	20	20	125	27	20	29	TP_R1603_	SR3	CH6R3	HW20L HW40L	SHX0310 MHX0630	ST32CC	
	2525-M16C		○ ●	25	25	150	32	25	32		TN_N1604_ TN_N1607_	SR3	CH6R3	HW20L HW40L	SHX0310 MHX0630	ST32CC
	3225-P16C		○	32	25	170	32	32	29		TP_R1603_	SR3	CH6R3	HW20L HW40L	SHX0310 MHX0630	ST32CC



CTGNR/L

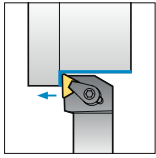

90°

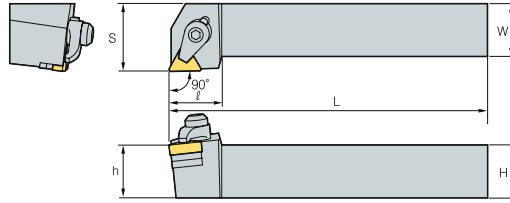

WSP



TN_

(mm)

Bezeichnung		L	R	H	W	L	S	h	ℓ	WSP	Feder	Klemme	Schlüssel	Schraube	Zwischenlage
CTGNR/L	2020-K16C		○	20	20	125	25	20	26	TN_N1604_ TN_N1607_	SR3	CH6R3	HW20L HW40L	SHX0310 MHX0630	ST32CC
	2525-M16C		○ ●	25	25	150	32	25	26		SR3	CH6R3	HW20L HW40L	SHX0310 MHX0630	ST32CC
	3225-P16C		○	32	25	170	32	32	26		SR3	CH6R3	HW20L HW40L	SHX0310 MHX0630	ST32CC



S 12 M - S T F P R - 11

1

Schaftausführung

2

Schaftdurchmesser

3

Werkzeuglänge

4

Spannsystem

5

Wendeschneidplattenform

6

Einstellwinkel

7

Freiwinkel

8

Werkzeugrichtung

9

Schneidkantenlänge

1 Schaftausführung
S 12 M - S T F P R - 11

- S Stahlschaft
- A Stahl mit Kühlmittelbohrung
- C Hartmetallschaft
- E Hartmetallstange mit festem Stahlkopf und Kühlmittelbohrung
- X Spezialausführung

2 Schaftdurchmesser
S 12 M - S T F P R - 11

3 Werkzeuglänge
S 12 M - S T F P R - 11

Länge (L)	(mm)
H	100
J	110
K	125
M	150
N	160
Q	180
R	200
S	250
T	300
U	350
V	400
W	450
Y	500

4 Spannsystem
S 12 M - S T F P R - 11

5 Wendeschneidplattenform
S 12 M - S T F P R - 11

6 Einstellwinkel
S 12 M - S T F P R - 11

7 Freiwinkel
S 12 M - S T F P R - 11

8 Werkzeugrichtung
S 12 M - S T F P R - 11

9 Schneidkantenlänge
S 12 M - S T F P R - 11



Anweisungen zur Montage von Bohrstangen

Doppelklemmsystem (D)

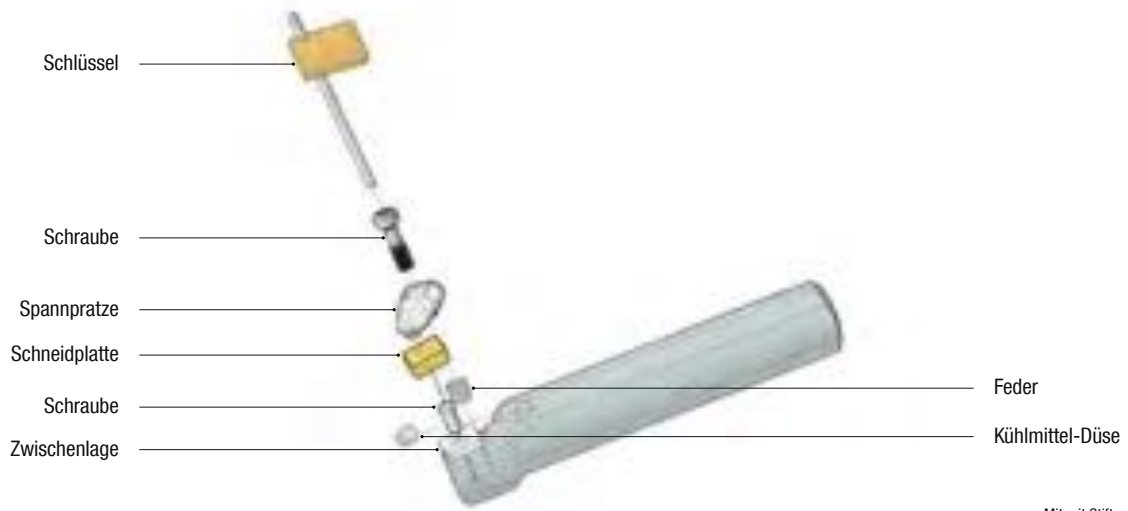

Kniehebelsystem (P)

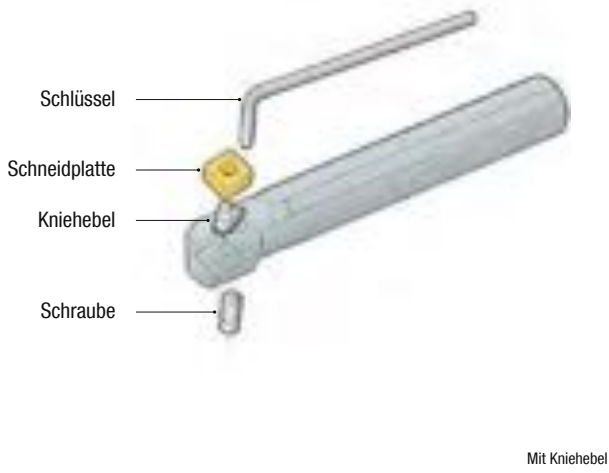

Klemmsystem (C)

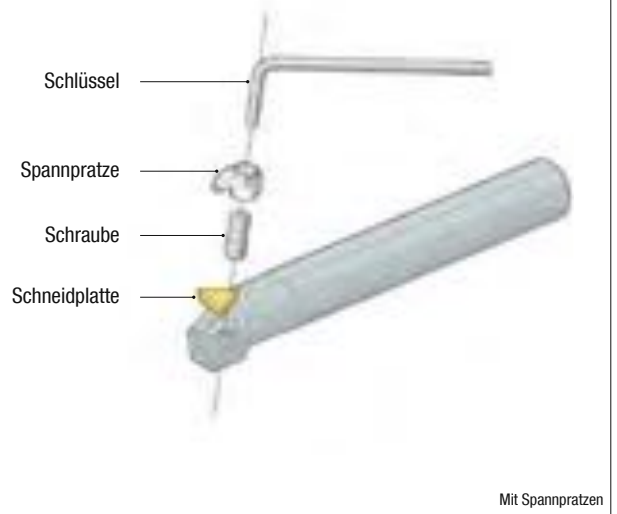

Mehrfachklemmsystem (M)

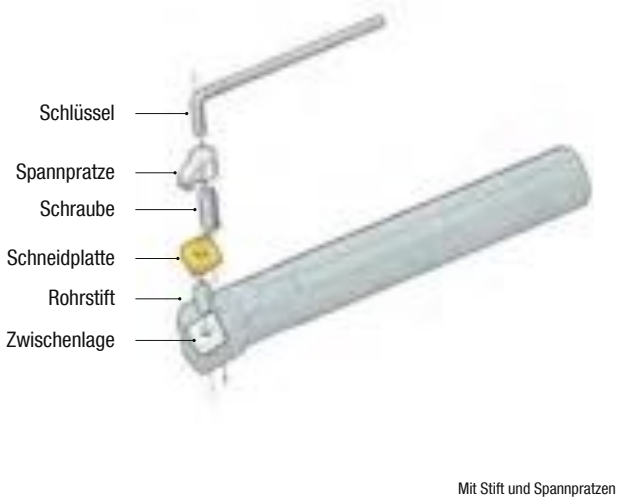

Schraubensystem (S)

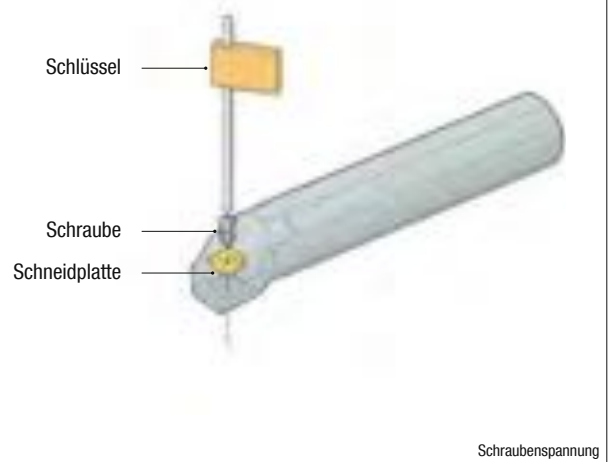



Doppelklemmsystem

Schnittform								
Bezeichnung	DCLNR/L	DDSNR/L	DDUNR/L	DSKNR/L	DTFNR/L	DWLNR/L		
Anstellwinkel	95°	95°	93°	75°	90°	95°		
Seite	59	59	59	60	60	61		
Kopieren			•					
Plandrehen	•	•				•		
Rückwärtsdrehen			•					
Drehen	•	•	•	•	•	•		

Kniehebelsystem

Schnittform								
Bezeichnung	PCLNR/L	PDQNR/L	PDSNR/L	PDUNR/L	PSKNR/L	PTFNR/L	PWLNR/L	
Anstellwinkel	95°	62,5°	62,5°	93°	75°	90°	95°	
Seite	62	63	63	64	65	65	66	
Kopieren		•	•	•				
Plandrehen	•						•	
Rückwärtsdrehen		•	•	•		•	•	
Drehen	•	•	•	•	•	•	•	

Klemmsystem

Schnittform							
Bezeichnung	CKUNR/L	CSKPR/L	CTFPR/L				
Anstellwinkel	93°	75°	90°				
Seite	67	68	68				
Kopieren							
Plandrehen							
Rückwärtsdrehen	•						
Drehen	•	•	•				

Mehrfachklemmsystem

Schnittform								
Bezeichnung	MCLNR/L	MDUNR/L	MSKNR/L	MTFNR/L	MTUNR/L	MVUNR/L	MWLNR/L	
Anstellwinkel	95°	93°	75°	90°	90°	93°	95°	
Seite	69	69	70	70	70	71	71	
Kopieren		•				•		
Plandrehen	•						•	
Rückwärtsdrehen		•				•		
Drehen	•	•	•	•	•	•	•	



Schraubsystem

Schnittform										
Bezeichnung	SCKCR/L	SCLCR/L	SCLPR/L	SDQCR/L	SDUCR/L	SDZCR/L	SSKCR/L	SSSCR/L	SSKPR/L	STFCR/L
Anstellwinkel	95°	95°	95°	107.5°	93°	3°	75°	75°	75°	90°
Seite	72	72	73	73	74	75	75	76	76	77
Kopieren				•	•					
Plandrehen	•	•	•							
Rückwärtsdrehen				•	•	•				
Drehen	•	•	•	•	•	•	•	•	•	•

Schnittform										
Bezeichnung	STFPR/L	STUBR/L	STUPR/L	STWPR/L	SVJCR/L	SVQBR/L	SVQCR/L	SVUBR/L	SVUCR/L	SWLCR/L
Anstellwinkel	90°	90°	90°	60°	142°	108°	108°	93°	93°	95°
Seite	77	78	78	79	79	80	80	81	81	82
Kopieren					•	•	•	•	•	•
Plandrehen										
Rückwärtsdrehen	•	•	•			•	•	•	•	•
Drehen	•	•	•	•	•	•	•	•	•	•



Compact Mini

Schnittform								
Bezeichnung	SCLCR/L	STUBR/L	STUPR/L	SWUBR/L				
Anstellwinkel	95°	93°	93°	93°				
Seite	83	83	84	85				
Kopieren								
Plandrehen	•	•						
Rückwärtsdrehen			•					
Drehen	•	•	•	•				

Bohrstange mit Hartmetallschaft

Bezeichnung	SCLCR/L	SCLPR/L	SDQCR/L	SDUCR/L	STFCR/L
Anstellwinkel	95°	95°	107,5°	93°	91°
Seite	85	86	86	87	88

Bezeichnung	STFPR/L	STUBR/L	STUPR/L	SWUBR/L	
Anstellwinkel	91°	93°	93°	93°	
Seite	89	89	90	90	



DCLNR/L

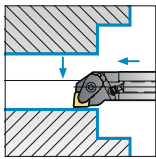

95°

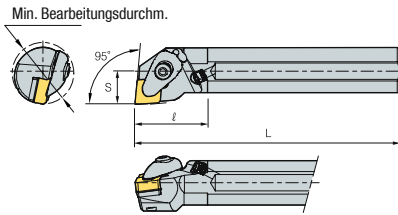

WSP



CN_

Bezeichnung	L	R	ØD	Ød	H	L	S	ℓ	Spannflächen	WSP	Düse	Feder	Klemme	Klemmschraube	Lagenschraube	Schlüssel	Zwischenlage
A25R-DCLNR/L-09	●	○	32	25	23	200	17	27	3	CN_0903_	CN0605	SPR0510	CVH3	CHX0415	FTKA0307	HW25P	SC32V
A25R-DCLNR/L-12	▲	▲	32	25	23	200	17	28	3	CN_1204_	CN0605	SPR0714	CVH4	CHX0518	FTKA0410	HW30P	SC42V
A32S-DCLNR/L-12	▲	▲	40	32	30	250	22	27	3	CN_1204_	CN0605	SPR0714	CVH4	CHX0518	FTKA0410	HW30P	SC42V
A32U-DCLNR/L-12	▲	▲	40	32	30	350	22	27	3		CN0605	SPR0714	CVH4	CHX0518	FTKA0410	HW30P	SC42V
A40T-DCLNR/L-12	▲	▲	50	40	37	300	27	30	3		CN0605	SPR0714	CVH4	CHX0518	FTKA0410	HW30P	SC42V
A40V-DCLNR/L-12	▲	▲	50	40	37	400	27	60	3		CN0605	SPR0714	CVH4	CHX0518	FTKA0410	HW30P	SC42V
A50U-DCLNR/L-16	▲	▲	63	50	47	350	35	40	3	CN_1606_	CN0605	SPR0811	CVH5	CHX0622	FTNA0511	HW40L	SC54V

(mm)

DDSNR/L

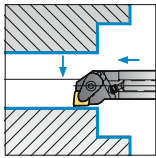

95°

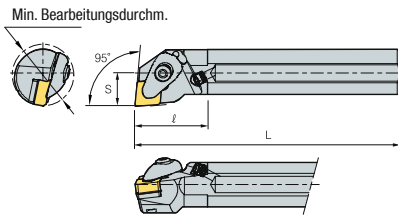

WSP



CN_

Bezeichnung	L	R	ØD	Ød	H	L	S	ℓ	Spannflächen	WSP	Düse	Feder	Klemme	Klemmschraube	Lagenschraube	Schlüssel	Zwischenlage
S32S-DDSNR/L-11	▲	▲	40	32	30	250	22	25	3	DN_1104_	CN0605	SPR0510	CVH3	CHX0415	FTKA0307	HW25P	SD32V

(mm)

DDUNR/L

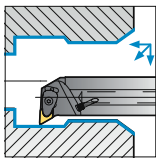

93°

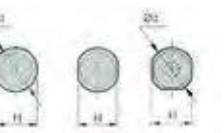
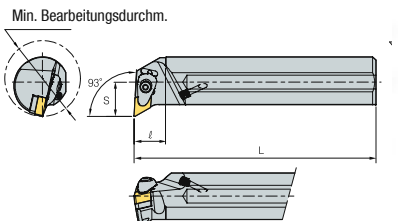

WSP



DN_

Bezeichnung	L	R	ØD	Ød	H	L	S	ℓ	Spannflächen	WSP	Düse	Feder	Klemme	Klemmschraube	Lagenschraube	Schlüssel	Zwischenlage
A32S-DDUNR/L-11	▲	▲	40	32	30	250	22	25	3	DN_1104_	CN0605	SPR0510	CVH3	CHX0415	FTKA0307	HW25P	SD32V
A40V-DDUNR/L-15	▲	▲	50	40	37	400	27	60	3	DN_1506_	CN0605	SPR0714	CVH4	CHX0518	FTKA0410	HW30P	SD44V
A40T-DDUNR/L-15	▲	▲	50	40	37	300	27	25	3	DN_1504_	CN0605	SPR0714	CVH4	CHX0518	FTKA0410	HW30P	SD44V
A40T-DDUNR/L-15-3	○	▲	50	40	37	300	27	25	3		CN0605	SPR0714	CVH4	CHX0518	FTKA0410	HW30P	SD43V
A50U-DDUNR/L-15	▲	▲	63	50	47	350	35	30	3	DN_1506_	CN0605	SPR0714	CVH4	CHX0518	FTKA0410	HW30P	SD44V
A50U-DDUNR/L-15-3	○	○	63	50	47	350	35	30	3	DN_1504_	CN0605	SPR0714	CVH4	CHX0518	FTKA0410	HW30P	SD43V

(mm)



DSKNR/L

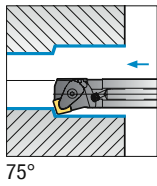

75°

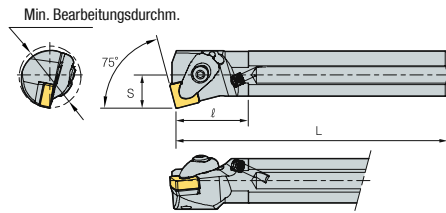

WSP



SN_

(mm)

Bezeichnung	L	R	ØD	Ød	H	L	S	ℓ	Spannflächen	WSP	Düse	Feder	Klemme	Klemmschraube	Lagerschraube	Schlüssel	Zwischenlage
A25R-DSKNR/L-09	●	●	32	25	23	200	17	27	3	SN_0903_	CN0605	SPR0510	CVH3	CHX0415	FTKA0307	HW25P	SS32V
A25R-DSKNR/L-12	▲	▲	32	25	23	200	17	28	3	SN_1204_	CN0605	SPR0714	CVH4	CHX0518	FTKA0410	HW30P	SS42V
A32S-DSKNR/L-12	▲	●	40	32	30	250	22	28	3		CN0605	SPR0714	CVH4	CHX0518	FTKA0410	HW30P	SS42V
A40T-DSKNR/L-12	▲	▲	50	40	37	300	27	28	3		CN0605	SPR0714	CVH4	CHX0518	FTKA0410	HW30P	SS42V

DTFNR/L

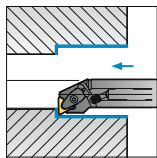

90°

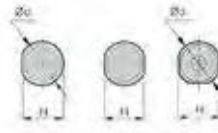
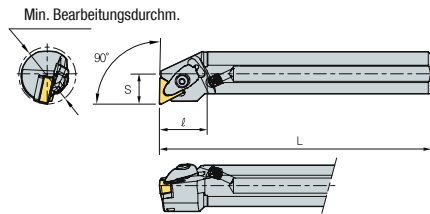

WSP



TN_

(mm)

Bezeichnung	L	R	ØD	Ød	H	L	S	ℓ	Spannflächen	WSP	Düse	Feder	Klemme	Klemmschraube	Lagerschraube	Schlüssel	Zwischenlage
A25R-DTFNR/L-16	▲	▲	32	25	23	200	17	27	3	TN_1604_	CN0605	SPR0510	CVH3	CHX0415	FTKA0307	HW25P	ST32V
A32S-DTFNR/L-16	○	▲	40	32	30	250	22	27	3		CN0605	SPR0510	CVH3	CHX0415	FTKA0307	HW25P	ST32V
A40T-DTFNR/L-22	▲	▲	50	40	37	300	27	33	3	TN_2204_	CN0605	SPR0714	CVH4	CHX0518	FTKA0410	HW30P	ST44V
A50U-DTFNR/L-22	▲	▲	63	50	47	350	35	33	3		CN0605	SPR0714	CVH4	CHX0518	FTKA0410	HW30P	ST44V
S32S-DTFNR/L-16	▲	▲	40	32	30	250	22	27	3	TN_1604_	CN0605	SPR0510	CVH3	CHX0415	FTKA0307	HW25P	ST32V
S32U-DTFNR/L-16	▲	▲	40	32	30	350	22	33	3		CN0605	SPR0510	CVH3	CHX0415	FTKA0307	HW25P	ST32V



DWLNR/L

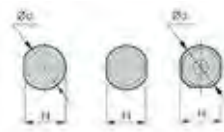
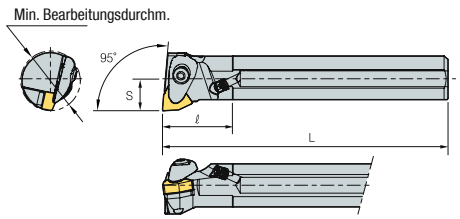
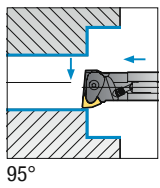

WSP



WN_

Bezeichnung	L	R	ØD	Ød	H	L	S	ℓ	Spannflächen	WSP	Düse	Feder	Klemme	Klemmschraube	Lagerschraube	Schlüssel	Zwischenlage
A25R-DWLNR/L-06	▲	▲	32	25	23	200	17	19	3	WN_0604_	CN0605	SPR0510	CVH3	CHX0415	FTKA0307	HW25P	SW32V
A25R-DWLNR/L-08	▲	▲	33	25	23	200	17	20	3	WN_0804_	CN0605	SPR0714	CVH4	CHX0518	FTKA0410	HW30P	SW42V
A32S-DWLNR/L-06	▲	▲	40	32	30	250	22	20	3	WN_0604_	CN0605	SPR0510	CVH3	CHX0415	FTKA0307	HW25P	SW32V
A32S-DWLNR/L-08	▲	▲	40	32	30	250	22	24	3	WN_0804_	CN0605	SPR0714	CVH4	CHX0518	FTKA0410	HW30P	SW42V
A40T-DWLNR/L-06	●	▲	50	40	37	300	27	25	3	WN_0604_	CN0605	SPR0510	CVH3	CHX0415	FTKA0307	HW25P	SW32V
A40T-DWLNR/L-08	▲	▲	50	40	37	300	27	25	3	WN_0804_	CN0605	SPR0714	CVH4	CHX0518	FTKA0410	HW30P	SW42V
A50U-DWLNR/L-08	▲	▲	63	50	47	350	35	32	3		CN0605	SPR0714	CVH4	CHX0518	FTKA0410	HW30P	SW42V
S40V-DWLNR/L-08	▲		50	40	37	400	27	35	3		CN0605	SPR0714	CVH4	CHX0518	FTKA0410	HW30P	SW42V

Doppelklemmsystem

- Verbesserte Standzeiten durch das leistungsstarke Klemmsystem und die optimierte Konstruktion
- Justierbare Kühlmitteldüse* zur optimalen Ausrichtung auf die Schneidkante

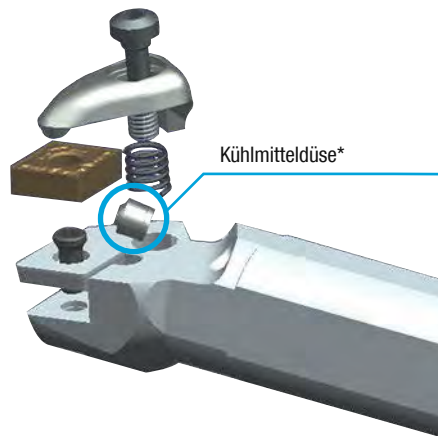
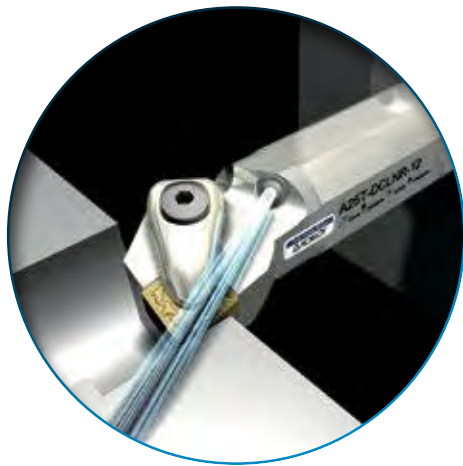



PDQNR/L

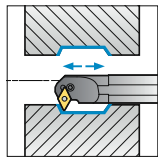

62,5°

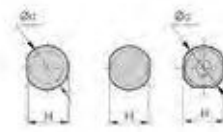
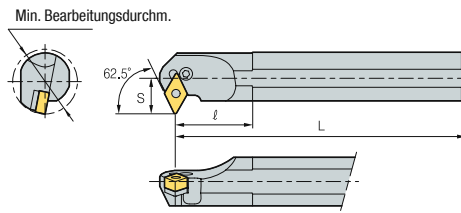

WSP



DN_

(mm)

Bezeichnung	L	R	ØD	Ød	H	L	S	ℓ	Spannflächen	WSP	Kniehebel	Rohrstift	Rohrstift-Dorn	Schlüssel	Schraube	Zwischenlage
A32S-PDQNR-11		○	40	32	31	250	22	45	3	DN__1104__	LV4B	SP4	LSPS4	HW30L	VHX0821	SD42
A32S-PDQNL-15	○		40	32	31	250	22	45	3	DN__1506__	LV4B	SP4	LSPS4	HW30L	VHX0821	SD42

PDSNR/L

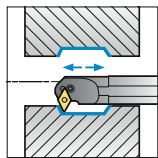

62,5°

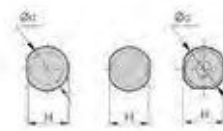
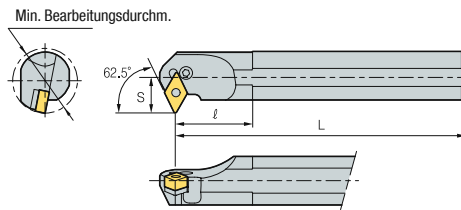

WSP



DN_

(mm)

Bezeichnung	L	R	ØD	Ød	H	L	S	ℓ	Spannflächen	WSP	Kniehebel	Rohrstift	Rohrstift-Dorn	Schlüssel	Schraube	Zwischenlage
A32S-PDSNR/L-15	○	○	40	32	31	250	22	45	3	DN__1506__	LV4B	SP4	LSPS4	HW30L	VHX0821	SD42
A32S-PDSNR/L-15N	○	○	40	32	30	250	22	15	3		LV4BN	SP4N	LSPS4	HW30L	VHX0821	SD42N
A32S-PDSNR/L-15-3	○	○	40	32	31	250	22	45	3	DN__1504__	LV4	SP4	LSPS4	HW30L	VHX0821	SD42
A32S-PDSNR/L-15-3N	○	○	40	32	30	450	22	15	3		LV4BN	SP4N	LSPS4	HW30L	VHX0821	SD43N
A40T-PDSNR/L-15N	○	○	50	40	37	300	27	15	3	DN__1506__	LV4BN	SP4N	LSPS4	HW30L	VHX0821	SD42N
A40T-PDSNR/L-15-3N	○	○	50	40	37	300	27	15	3	DN__1504__	LV4BN	SP4N	LSPS4	HW30L	VHX0821	SD43N
S32S-PDSNR/L-15	▲	▲	40	32	30	250	22	45	3	DN__1506__	LV4B	SP4	LSPS4	HW30L	VHX0821	SD42
S32S-PDSNR/L-15N	●	●	40	32	30	250	22	15	3		LV4BN	SP4N	LSPS4	HW30L	VHX0821	SD42N
S32S-PDSNR/L-15-3	○	○	40	32	30	450	22	45	3	DN__1504__	LV4	SP4	LSPS4	HW30L	VHX0821	SD42
S32S-PDSNR/L-15-3N	○	○	40	32	30	250	22	15	3		LV4BN	SP4N	LSPS4	HW30L	VHX0821	SD43N
S32U-PDSNR/L-15	○	▲	40	32	30	350	22	45	3	DN__1506__	LV4B	SP4	LSPS4	HW30L	VHX0821	SD42
S32U-PDSNR/L-15-3	○		40	32	30	350	27	45	3	DN__1504__	LV4	SP4	LSPS4	HW30L	VHX0821	SD42
S40T-PDSNR/L-15	●	●	50	40	37	300	27	43	3	DN__1506__	LV4B	SP4	LSPS4	HW30L	VHX0821	SD42
S40T-PDSNR/L-15N	●	●	50	40	37	300	27	15	3		LV4BN	SP4N	LSPS4	HW30L	VHX0821	SD42N
S40T-PDSNR/L-15-3	○	○	50	40	37	300	27	43	3	DN__1504__	LV4	SP4	LSPS4	HW30L	VHX0821	SD42
S40T-PDSNR/L-15-3N	○	○	50	40	37	300	27	15	3		LV4BN	SP4N	LSPS4	HW30L	VHX0821	SD43N
S40V-PDSNR/L-15		○	50	40	37	400	27	45	3	DN__1506__	LV4B	SP4	LSPS4	HW30L	VHX0821	SD42
S40V-PDSNR/L-15-3	○		50	40	37	400	27	45	3	DN__1504__	LV4	SP4	LSPS4	HW30L	VHX0821	SD42



PDUNR/L

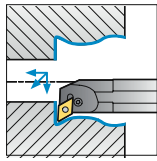

93°

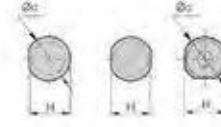
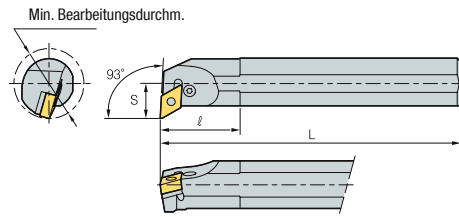

WSP



DN_

(mm)

Bezeichnung	L	R	ØD	Ød	H	L	S	ℓ	Spannflächen	WSP	Kniehebel	Rohrstift	Rohrstift-Dorn	Schlüssel	Schraube	Zwischenlage
A20S-PDUNR/L-11N	○	○	25	20	18	250	13	25	3	DN_1104_	LV3DN	-	-	HW20L	VHX0512BN	-
A25R-PDUNR/L-11N	○	○	32	25	23	200	17	35	2		LV3DN	-	-	HW20L	VHX0512BN	-
A32S-PDUNR/L-11N	○	○	40	32	30	250	22	40	3		LV3AN	SP3N-1	LSPS3	HW30L	VHX0617N	SD317N
A32S-PDUNR/L-15	▲	▲	40	32	31	250	22	50	3	DN_1506_	LV4B	SP4	LSPS4	HW30L	VHX0821	SD42
A32S-PDUNR/L-15-3	○	○	40	32	31	250	22	50	3	DN_1504_	LV4	SP4	LSPS4	HW30L	VHX0821	SD42
A32S-PDUNR/L-15-3N	○	▲	40	32	30	250	22	50	3		LV4BN	SP4N	LSPS4	HW30L	VHX0821N	SD43N
A32S-PDUNR/L-15N	▲	▲	40	32	30	250	22	50	3	DN_1506_	LV4BN	SP4N	LSPS4	HW30L	VHX0821N	SD42N
A40T-PDUNR/L-15	▲	▲	50	40	37	300	27	60	3		LV4B	SP4	LSPS4	HW30L	VHX0821	SD42
A40T-PDUNR/L-15-3N	○	○	50	40	37	300	27	50	3	DN_1504_	LV4BN	SP4N	LSPS4	HW30L	VHX0821N	SD43N
A40T-PDUNR/L-15N	○	○	50	40	37	300	27	50	3	DN_1506_	LV4BN	SP4N	LSPS4	HW30L	VHX0821N	SD42N
A50U-PDUNR/L-15N	○	○	63	50	47	350	35	50	3		LV4BN	SP4N	LSPS4	HW30L	VHX0821N	SD42N
S20S-PDUNR/L-11	▲	▲	25	20	18	250	13	30	3	DN_1104_	LV3D	-	-	HW20L	VHX0512B	-
S20S-PDUNR/L-11N	○	○	25	20	18	250	13	25	3		LV3DN	-	-	HW20L	VHX0512BN	-
S25R-PDUNR/L-11	▲	▲	32	25	23	200	17	35	3		LV3D	-	-	HW20L	VHX0512B	-
S25R-PDUNR/L-11N	●	○	32	25	23	200	17	35	3		LV3DN	-	-	HW20L	VHX0512BN	-
S25T-PDUNR/L-11	▲	▲	32	25	23	300	17	35	3		LV3D	-	-	HW20L	VHX0512B	-
S32S-PDUNR/L-11	○		40	32	30	250	22	40	3		LV3	SP3	LSPS3	HW25L	VHX0617	SD317
S32S-PDUNL-11-5N	●	●	40	32	30	250	22	40	3	DN_1105_	LV3AN	SP3N-0	LSPS2	HW30L	VHX0617N	SD317N
S32S-PDUNR/L-11N	○	○	40	32	30	250	22	40	3	DN_1104_	LV3AN	SP3N-1	LSPS3	HW30L	VHX0617N	SD317N
S32S-PDUNR/L-15	▲	▲	40	32	30	250	22	50	3	DN_1506_	LV4B	SP4	LSPS4	HW30L	VHX0821	SD42
S32S-PDUNR/L-15-3	○	○	40	32	30	250	22	50	3	DN_1504_	LV4	SP4	LSPS4	HW30L	VHX0821	SD42
S32S-PDUNR/L-15-3N	○	○	40	32	30	250	22	50	3		LV4BN	SP4N	LSPS4	HW30L	VHX0821N	SD43N
S32S-PDUNR/L-15N	●	○	40	32	30	250	22	50	3	DN_1506_	LV4BN	SP4N	LSPS4	HW30L	VHX0821N	SD42N
S32U-PDUNR/L-11	▲	▲	40	32	30	350	22	40	3	DN_1104_	LV4B	SP4	LSPS4	HW30L	VHX0821	SD42
S32U-PDUNR/L-15	▲	▲	40	32	30	350	22	50	3	DN_1506_	LV4B	SP4	LSPS4	HW30L	VHX0821	SD42
S32U-PDUNR/L-15-3	○		40	32	30	350	22	50	3	DN_1504_	LV4	SP4	LSPS4	HW30L	VHX0821	SD42
S32U-PDUNR/L-15N	○	●	40	32	30	350	22	50	3	DN_1506_	LV4BN	SP4	LSPS4	HW30L	VHX0821N	SD42N
S40T-PDUNR/L-11-5N	●	●	50	40	37	300	27	50	3	DN_1105_	LV3AN	SP3N-0	LSPS2	HW30L	VHX0617N	SD317N
S40T-PDUNR/L-15	▲	▲	50	40	37	300	27	50	3	DN_1506_	LV4B	SP4	LSPS4	HW30L	VHX0821	SD42
S40T-PDUNR/L-15-3	○	○	50	40	37	300	27	50	3	DN_1504_	LV4	SP4	LSPS4	HW30L	VHX0821	SD42
S40T-PDUNR/L-15-3N	○	○	50	40	37	300	27	50	3		LV4BN	SP4N	LSPS4	HW30L	VHX0821N	SD43N
S40T-PDUNR/L-15N	●	○	50	40	37	300	27	50	3	DN_1506_	LV4BN	SP4N	LSPS4	HW30L	VHX0821N	SD42N
S40V-PDUNR/L-15	▲	▲	50	40	37	400	27	50	3		LV4B	SP4	LSPS4	HW30L	VHX0821	SD42
S40V-PDUNR/L-15-3		○	50	40	37	400	27	50	3	DN_1504_	LV4	SP4	LSPS4	HW30L	VHX0821	SD42
S50U-PDUNR/L-15	▲	▲	63	50	47	350	35	63	3	DN_1506_	LV4B	SP4	LSPS4	HW30L	VHX0821	SD42
S50U-PDUNR/L-15N	●	○	63	50	47	350	35	50	3		LV4BN	SP4N	LSPS4	HW30L	VHX0821N	SD42N
S50W-PDUNR/L-15	▲	▲	63	50	47	450	35	55	3		LV4B	SP4	LSPS4	HW30L	VHX0821	SD42



PSKNR/L

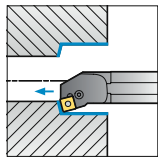

75°

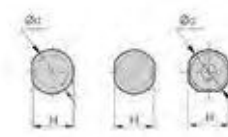
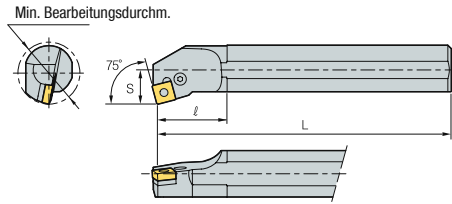

WSP



SN_

(mm)

Bezeichnung	L	R	ØD	Ød	H	L	S	ℓ	Spannflächen	WSP	Kniehebel	Rohrstift	Rohrstift-Dorn	Schlüssel	Schraube	Zwischenlage
A25R-PSKNR/L-12	○	▲	32	25	23	200	17	42	1	SN_1204_	LV4A	SP4	-	HW25L	VHX0613A	-
A25R-PSKNR/L-12N	○	○	32	25	23	200	17	25	3		LV4AN	-	-	HW25L	VHX0613N	-
A32S-PSKNR/L-12	○	▲	40	32	30	250	22	50	1		LV4	SP4	LSPS4	HW30L	VHX0821	SS42B
A32S-PSKNR/L-12N	○	○	40	32	30	250	22	30	3		LV4N	SP4N	LSPS4	HW30L	VHX0821N	SS42N
A40T-PSKNR/L-12N	○	○	50	40	37	300	27	30	3	LV4N	SP4N	LSPS4	HW30L	VHX0821N	SS42N	
S25R-PSKNR/L-09-4N	●	●	32	25	23	200	17	25	3	SN_0903_	LV4AN	-	-	HW25L	VHX0613N	-
S25R-PSKNR/L-12	▲	▲	32	25	23	200	17	42	3	SN_1204_	LV4A	-	-	HW25L	VHX0613A	-
S25R-PSKNR/L-12N	●	●	32	25	23	200	17	25	3		LV4AN	-	-	HW25L	VHX0613N	-
S25T-PSKNR/L-12	○	▲	32	25	23	300	17	42	3	LV4A	-	-	HW25L	VHX0613A	-	
S32S-PSKNR/L-09-4N	●	●	40	32	30	250	22	30	3	SN_0903_	LV4N	SP4N	LSPS4	HW30L	VHX0821N	SS42N
S32S-PSKNR/L-12	▲	▲	40	32	30	250	22	45	3	SN_1204_	LV4	SP4	LSPS4	HW30L	VHX0821	SS42B
S32S-PSKNR/L-12N	○	●	40	32	30	250	22	30	3		LV4N	SP4N	LSPS4	HW30L	VHX0821N	SS42N
S32U-PSKNR/L-12	○	▲	40	32	30	350	22	45	3	LV4	SP4	LSPS4	HW30L	VHX0821	SS42B	
S40T-PSKNR/L-12	▲	▲	50	40	37	300	27	50	3	LV4	SP4	LSPS4	HW30L	VHX0821	SS42B	
S40T-PSKNR/L-12N	○	●	50	40	37	300	27	30	3	LV4N	SP4N	LSPS4	HW30L	VHX0821N	SS42N	
S40V-PSKNR/L-12		○	50	40	37	400	27	50	3	LV4	SP4	LSPS4	HW30L	VHX0821	SS42B	

PTFNR/L

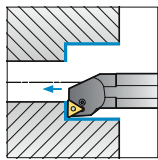

90°

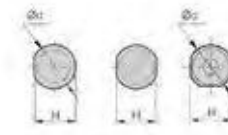
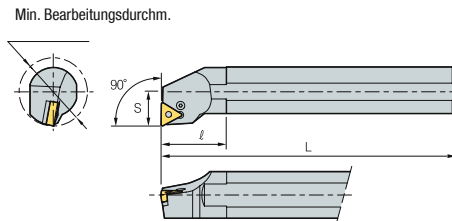

WSP



TN_

(mm)

Bezeichnung	L	R	ØD	Ød	H	L	S	ℓ	Spannflächen	WSP	Kniehebel	Rohrstift	Rohrstift-Dorn	Schlüssel	Schraube	Zwischenlage
A25R-PTFNR/L-16	○	▲	32	25	24	200	17	40	1	TN_1604_	LV3	SP3	LSPS3	HW25L	VHX0617	ST317B
A25R-PTFNR/L-16N	○	▲	32	25	23	200	17	42	3		LV3BN	-	-	HW20L	VHX0512B	-
A32S-PTFNR/L-16	○	▲	40	32	31	250	22	50	1		LV3	SP3	LSPS3	HW25L	VHX0617N	ST317B
A32S-PTFNR/L-16N	○	○	44	32	30	250	22	50	1		LV3N	SP3N	LSPS3	HW25L	VHX0617N	ST317N
A40T-PTFNR/L-16		○	54	40	37	300	27	55	1	LV4	SP4	LSPS4	HW30L	VHX0821	SS42B	
A40T-PTFNR/L-16N	○	○	54	40	37	300	27	55	1	LV3N	SP3N	LSPS3	HW25L	VHX0617N	ST317N	
S16R-PTFNR/L-11	○	▲	20	16	15	200	11	28	3	TN_1103_	LV2	-	-	HW25L	VHX0509B	-
S20S-PTFNR/L-11	○	▲	25	20	18	250	13	3	3		LV2	-	-	HW25L	VHX0509B	-
S25R-PTFNR/L-11	○	●	32	25	23	200	17	36	3		LV2	-	-	HW25L	VHX0509B	-
S25R-PTFNR/L-16	▲	▲	32	25	23	200	17	42	3	TN_1604_	LV3B	-	-	HW20L	VHX0512B	-
S25R-PTFNR/L-16N	○	○	32	25	23	200	17	42	3	LV3BN	-	-	HW20L	VHX0512B	-	
S25T-PTFNR/L-11		▲	32	25	23	300	17	36	3	TN_1103_	LV3B	-	-	HW20L	VHX0512B	-
S25T-PTFNR/L-16	▲	▲	32	25	23	300	17	40	3	TN_1604_	LV3B	-	-	HW20L	VHX0512B	-
S25T-PTFNR/L-16N	○	●	32	25	23	300	17	40	3		LV3B	-	-	HW20L	VHX0512B	-
S32S-PTFNR/L-16	●	▲	44	32	30	250	22	50	3	LV3	SP3	LSPS3	HW25L	VHX0617	ST317B	
S32S-PTFNR/L-16N	●	●	44	32	30	250	22	50	3	LV3N	SP3N	LSPS3	HW25L	VHX0617N	ST317N	
S32U-PTFNR/L-16		▲	40	32	30	350	22	42	3	LV3	SP3	LSPS3	HW25L	VHX0617	ST317B	
S40T-PTFNR/L-16	●	▲	54	40	37	300	27	55	3	LV3	SP3	LSPS3	HW25L	VHX0617	ST317B	
S40T-PTFNR/L-16N	●	●	54	40	37	300	27	55	3	LV3N	SP3N	LSPS3	HW25L	VHX0617N	ST317N	
S40V-PTFNR/L-16	○	▲	40	40	37	400	27	40	3	LV3	SP3	LSPS3	HW25L	VHX0617	ST317B	



PWLNR/L

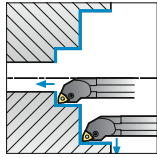

95°

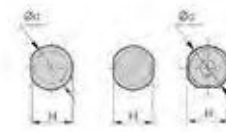
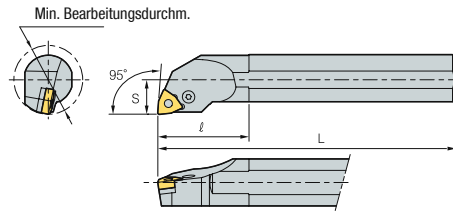

WSP



WN_

(mm)

Bezeichnung	L	R	ØD	Ød	H	L	S	ℓ	Spannflächen	WSP	Kniehebel	Rohrstift	Rohrstift-Dorn	Schlüssel	Schraube	Zwischenlage
A25T-PWLNR/L-08	▲	▲	32	25	23	300	17	42	1	WN_0804_	LV4A	-	-	HW25L	VHX0613A	-
S16Q-PWLNR/L-06		▲	20	16	15	180	11	40	3	WN_0604_	LV4A	-	-	HW25L	VHX0613A	-
S16R-PWLNR/L-06	○	▲	20	16	15	200	11	40	3		LV3B	-	-	HW20L	VHX0512B	-
S20S-PWLNR/L-06	▲	▲	25	20	18	250	13	40	3		LV3B	-	-	HW20L	VHX0512B	-
S20S-PWLNR/L-06N	○	○	25	20	18	250	13	40	3		LV3B	-	-	HW20L	VHX0512B	-
S25R-PWLNR/L-06	▲	▲	32	25	23	200	17	40	3		LV3B	SP3	LSPS3	HW25L	VHX0613B	SW317
S25R-PWLNR/L-06N	○	○	32	25	23	200	17	40	3		LV4	SP4	LSPS3	HW30L	VHX0821	SW42
S25R-PWLNR/L-08	▲	▲	32	25	23	200	17	45	3	WN_0804_	LV4	SP4	LSPS3	HW30L	VHX0821	SW42
S25R-PWLNR/L-08N	○	○	32	25	23	200	17	25	3		LV4	SP4	LSPS3	HW30L	VHX0821	SW42
S25T-PWLNR/L-06	○		32	25	23	300	17	40	3	WN_0604_	LV3B	-	-	HW20L	VHX0512B	-
S25T-PWLNR/L-08	○	▲	32	25	23	300	17	42	3	WN_0804_	LV3BN	-	-	HW20L	VHX0512BN	-
S32S-PWLNR/L-06	○	▲	44	32	30	250	22	45	3	WN_0604_	LV3BN	-	-	HW20L	VHX0512BN	-
S32S-PWLNR/L-06N	○	○	44	32	30	250	22	45	3		LV4A	-	-	HW25L	VHX0613A	-
S32S-PWLNR/L-08	▲	▲	44	32	30	250	22	50	3	WN_0804_	LV4AN	-	-	HW25L	VHX0613N	-
S32S-PWLNR/L-08N	○	○	44	32	30	250	22	25	3		LV3B	SP3	LSPS3	HW25L	VHX0613B	SW317
S32U-PWLNR/L-06	○	▲	40	32	30	350	22	48	3	WN_0604_	LV3B	-	-	HW20L	VHX0512B	-
S32U-PWLNR/L-08	○	▲	44	32	30	350	22	50	3	WN_0804_	LV3N	SP3N	LSPS3	HW25L	VHX0617N	SW317N
S40V-PWLNR/L-08		▲	50	40	37	400	27	58	3		LV4	SP4	LSPS3	HW30L	VHX0821	SW42
S40T-PWLNR/L-08		▲	54	40	37	300	27	55	3		LV4N	SP4N	LSPS4	HW30L	VHX0820N	SW42N



CKUNR/L

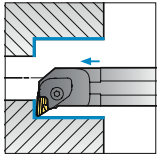

93°

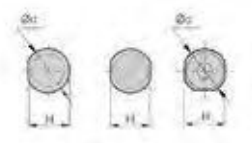
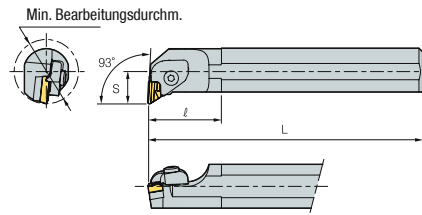

WSP



KN_

(mm)

Bezeichnung	L	R	ØD	Ød	H	L	S	ℓ	Spannflächen	WSP	Feder	Klemme	Klemmschraube	Lagenschraube	Schlüssel	Stift	Zwischenlage
S32S-CKUNL-16	▲		40	32	30	250	22	70	3	KN__1604__R	SR3 SR4	CTH6RI	CHX0625	SHX0310	HW20L HW40L	PN0515	SK33C
S32S-CKUNR-16		▲	40	32	30	250	22	70	3	KN__1604__L	SR3 SR4	CTH6LI	CHX0625	SHX0310	HW20L HW40L	PN0515	SK33CL
S32U-CKUNL-16		○	40	32	30	350	22	55	3	KN__1604__R	SR3 SR4	CTH6RI	CHX0625	SHX0310	HW20L HW40L	PN0515	SK33C
S32U-CKUNR-16		▲	40	32	30	350	22	55	3	KN__1604__L	SR3 SR4	CTH6RI	CHX0625	SHX0310	HW20L HW40L	PN0515	SK33C
S40T-CKUNL-16	▲		50	40	37	300	27	60	3	KN__1604__R	SR3 SR4	CTH6RI	CHX0625	SHX0310	HW20L HW40L	PN0515	SK33C
S40T-CKUNR-16		▲	50	40	37	300	27	60	3	KN__1604__L	SR3 SR4	CTH6LI	CHX0625	SHX0310	HW20L HW40L	PN0515	SK33CL
S40V-CKUNR-16		▲	50	40	37	400	27	60	3		SR3 SR4	CTH6RI	CHX0625	SHX0310	HW20L HW40L	PN0515	SK33C
S50U-CKUNL-16	▲		63	50	43	350	35	55	3	KN__1604__R	SR3 SR4	CTH6RI	CHX0625	SHX0310	HW20L HW40L	PN0515	SK33C
S50U-CKUNR-16		●	63	50	43	350	35	55	3	KN__1604__L	SR3 SR4	CTH6LI	CHX0625	SHX0310	HW20L HW40L	PN0515	SK33CL
S50W-CKUNR-16		○	63	50	47	450	35	65	3		SR3 SR4	CTH6RI	CHX0625	SHX0310	HW20L HW40L	PN0515	SK33C



CSKPR/L

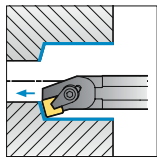

75°

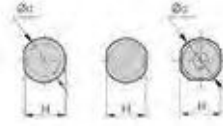
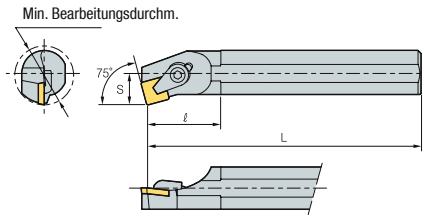

WSP

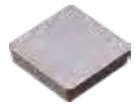

SP_

(mm)

Bezeichnung	L	R	ØD	Ød	H	L	S	ℓ	Spannflächen	WSP	C-Ring	Klemme	Klemmschraube	Schlüssel
S16R-CSKPR/L-09	▲	▲	20	16	15	200	11	30	3	SP_0903_	CR02C	CH4R1C	CHX0414	HW25L
S20S-CSKPR/L-09	○	●	25	20	18	250	13	36	2		CR02C	CH4R1C	CHX0414	HW25L
S20S-CSKPR/L-12	○	▲	25	20	18	250	13	28	3	SP_1203_	CR03C	CH5R5C	CHX0519C	HW30L
S25R-CSKPR/L-12	○	▲	32	25	23	200	17	40	3		CR04C	CH6R5	CH0616	HW30L
S25T-CSKPR/L-12	○	○	32	25	23	300	17	42	3		CR04C	CH6R5	CH0616	HW30L

CTFPR/L

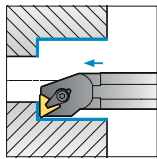

90°

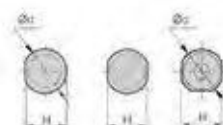
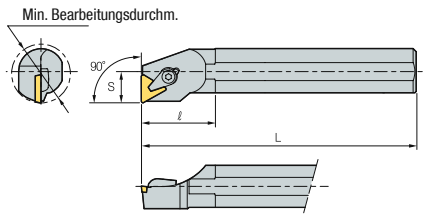

WSP



TP_

(mm)

Bezeichnung	L	R	ØD	Ød	H	L	S	ℓ	Spannflächen	WSP	C-Ring	Klemme	Klemmschraube	Rohrstift	Schlüssel	Zwischenlage
S12M-CTFPR/L-11	▲	▲	16	12	11	150	9	26	3	TP_1103_	CR02C	CH4R1C	CHX0414C	-	HW25L	-
S16R-CTFPR/L-11	▲	▲	20	16	15	200	11	40	3		CR02C	CH4R1C	CHX0414C	-	HW25L	-
S16R-CTFPR/L-16	▲	▲	20	16	15	200	11	40	3	TP_1603_	CR03C	CH5R5C	CHX0519C	-	HW30L	-
S20S-CTFPR/L-11	▲	▲	25	20	18	250	13	40	3	TP_1103_	CR02C	CH4R1C	CHX0414C	-	HW25L	-
S20S-CTFPR/L-16	▲	▲	25	20	18	250	13	40	3	TP_1603_	CR03C	CH5R5C	CHX0519C	-	HW30L	-
S25R-CTFPR/L-16	▲	▲	32	25	23	200	17	40	3		CR04C	CH6R5	CHX0622C	-	HW30L	-
S25T-CTFPR/L-16	▲	▲	32	25	23	300	17	40	3		CR04C	CH6R5	CHX0622C	SP3C	HW30L	ST32C
S32S-CTFPR/L-16	▲	▲	40	32	30	250	22	45	3		CR04C	CH6R5	CHX0622C	SP3C	HW30L	ST32C
S32U-CTFPR/L-16		▲	40	32	30	350	22	50	3		CR04C	CH6R5	CHX0622C	SP3C	HW30L	ST32C
S40T-CTFPR/L-16	▲	▲	50	40	37	300	27	60	3		CR04C	CH6R5	CHX0622C	SP3C	HW30L	ST32C
S40T-CTFPR/L-22	○	○	50	40	37	300	27	60	3	TP_2204_	CR05C	CH83R1	CH0823C	SP4C	HW40L	ST43C
S40V-CTFPR/L-16		▲	50	40	37	400	27	60	3	TP_1603_	CR04C	CH6R5	CHX0622C	SP3C	HW30L	ST32C
S40V-CTFPR/L-22		▲	50	40	37	400	27	60	3	TP_2204_	CR05C	CH83R1	CH0823C	SP4C	HW40L	ST43C



MCLNR/L

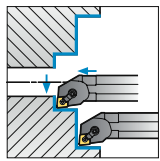

95°

Min. Bearbeitungsdurchm.

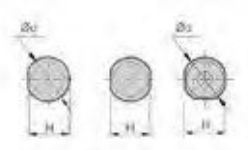
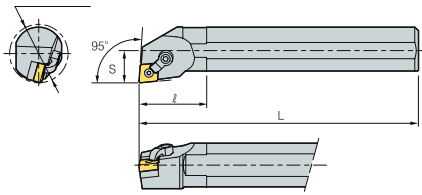

WSP



CN_

(mm)

Bezeichnung	L	R	ØD	Ød	H	L	S	ℓ	Spannflächen	WSP	Klemme	Klemmschraube	Rohrstift	Schlüssel	Zwischenlage
A25R-MCLNR/L-12	○	○	32	25	23	200	17	45	1	CN_1204_		DHA1/4-21	SP4DS	HW23.8L HW31.8L	-
A32S-MCLNR/L-12	○	○	40	32	30	250	22	45	1			DHA1/4-21	SP4D	HW23.8L HW31.8L	SC43D
A40V-MCLNL-19	○		50	40	37	400	27	50	1	CN_1906_		DHA1/4-21	SP4D	HW23.8L HW31.8L	SC43D
S20S-MCLNR/L-09	○	○	25	20	18	250	13	30	3	CN_0903_		DHA10-32-19	SP3D3S	"HW19.8L HW23.8L"	-
S25R-MCLNR/L-09	○	○	32	25	23	200	17	36	3	CN_0903_		DHA10-32-19	SP3D3S	"HW19.8L HW23.8L"	-
S25R-MCLNR/L-12	○	●	32	25	23	200	17	40	3	CN_1204_		DHA1/4-21	SP4DS	"HW23.8L HW31.8L"	-
S25T-MCLNR/L-12	○	○	32	25	23	300	17	35	3			DHA1/4-21	SP4DS	"HW23.8L HW31.8L"	-
S32S-MCLNR/L-12	○	●	40	32	30	250	22	45	3			DHA1/4-21	SP4D	"HW23.8L HW31.8L"	SC43D
S32U-MCLNR/L-12		○	40	32	30	350	22	45	3			DHA1/4-21	SP4D	"HW23.8L HW31.8L"	SC43D
S40T-MCLNR/L-12	○	○	50	40	37	300	27	50	3			DHA1/4-21	SP4D	"HW23.8L HW31.8L"	SC43D
S40V-MCLNR/L-12	○	○	50	40	37	400	27	50	3			DHA1/4-21	SP4D	"HW23.8L HW31.8L"	SC43D

MDUNR/L

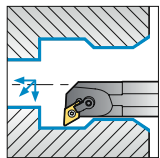

93°

Min. Bearbeitungsdurchm.

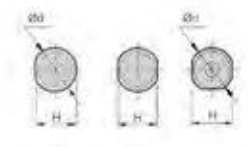
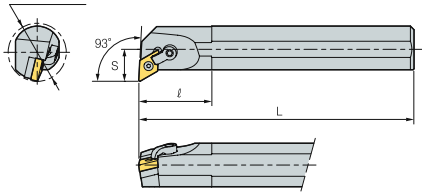

WSP



DN_

(mm)

Bezeichnung	L	R	ØD	Ød	H	L	S	ℓ	Spannflächen	WSP	Klemme	Klemmschraube	Rohrstift	Schlüssel	Zwischenlage
A32S-MDUNR/L-15-3	○	○	40	32	30	250	22	50	1	DN_1504_		DHA1/4-21	SP4D	HW23.8L HW31.8L	SD43D
S32S-MDUNR/L-15-3	○	○	40	32	30	250	22	50	3			DHA1/4-21	SP4D	HW23.8L HW31.8L	SD43D
S32U-MDUNR/L-15		○	40	32	30	350	22	50	3	DN_1506_		DHA1/4-21	SP4D	HW23.8L HW31.8L	SS43D
S32U-MDUNR/L-15-3	○		40	32	30	350	22	50	3	DN_1504_		DHA1/4-21	SP4D	HW23.8L HW31.8L	SS43D
S40T-MDUNR/L-15-3	○	○	50	40	37	300	27	60	3			DHA1/4-21	SP4D	HW23.8L HW31.8L	SD43D
S40V-MDUNR/L-15		○	50	40	37	400	27	60	3	DN_1506_		DHA1/4-21	SP4D	HW23.8L HW31.8L	SS43D
S40V-MDUNR/L-15-3	○	○	50	40	37	400	27	50	3	DN_1504_		DHA1/4-21	SP4D	HW23.8L HW31.8L	SS43D



MSKNR/L

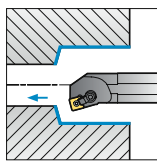

75°

Min. Bearbeitungsdurchm.

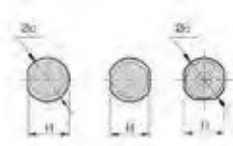
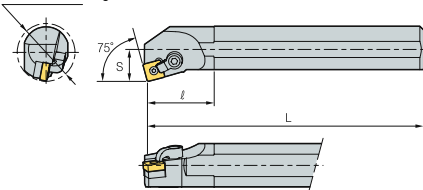

WSP



SN_

(mm)

Bezeichnung	L	R	ØD	Ød	H	L	S	ℓ	Spannflächen	WSP	Klemme	Klemmschraube	Rohrstift	Schlüssel	Zwischenlage
A25R-MSKNR/L-12	○	○	32	25	23	200	17	40	-	SN_1204_					
A32S-MSKNR/L-12	○	○	40	32	30	250	22	50	-		CDH8N1	DHA5/16-28	SP4DS	HW23.8L HW39.7L	SS43D
A40T-MSKNR/L-12	○	○	50	40	37	300	27	60	2		CDH8N1	DHA5/16-28	SP4D	HW23.8L HW39.7L	SS43D
S25R-MSKNR/L-12	○	○	32	25	23	200	17	36	-		CDH8N1	DHA5/16-28	SP4DS	HW23.8L HW39.7L	SS43D
S32S-MSKNR/L-12	○	○	40	32	30	250	22	50	3		CDH8N1	DHA5/16-28	SP4D	HW23.8L HW39.7L	SS43D
S40T-MSKNR/L-12	○	○	50	40	37	300	27	60	2		CDH8N1	DHA5/16-28	SP4D	HW23.8L HW39.7L	SS43D

MTFNR/L

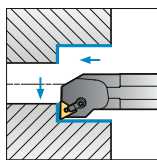

90°

Min. Bearbeitungsdurchm.

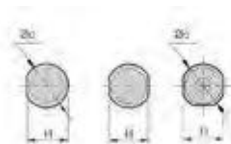
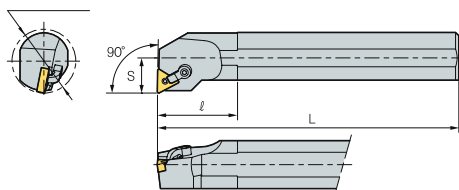

WSP



TN_

(mm)

Bezeichnung	L	R	ØD	Ød	H	L	S	ℓ	Spannflächen	WSP	Klemme	Klemmschraube	Rohrstift	Schlüssel	Zwischenlage
A25R-MTFNR/L-16	○	○	32	25	23	200	17	40	3	TN_1604_					
A32S-MTFNR/L-16	○	○	40	32	30	250	22	45	-		CDH7N1	DHA10-32-19	SP3D3	HW19.8L HW23.8L	-
S25R-MTFNR/L-16	○	○	32	25	23	200	17	40	3		CDH7N1	DHA10-32-19	SP3D	HW19.8L HW23.8L	ST32D
S25T-MTFNR/L-16		○	32	25	23	300	17	40	3		CDH7N1	DHA10-32-19	SP3D3	HW19.8L HW23.8L	-
S32S-MTFNR/L-16	○	○	40	32	30	250	22	45	3		CDH7N1	DHA10-32-19	SP3D	HW19.8L HW23.8L	ST32D
S32U-MTFNR/L-16		○	40	32	30	350	22	50	3		CDH7N1	DHA10-32-19	SP3D	HW19.8L HW23.8L	ST32D
S40T-MTFNR/L-16	○	○	50	40	37	300	27	55	3		CDH7N1	DHA10-32-19	SP3D	HW19.8L HW23.8L	ST32D
S40V-MTFNR/L-16		○	50	40	37	400	27	55	3		CDH7N1	DHA10-32-19	SP3D	HW19.8L HW23.8L	ST32D

MTUNR/L

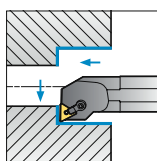

90°

Min. Bearbeitungsdurchm.

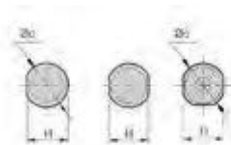
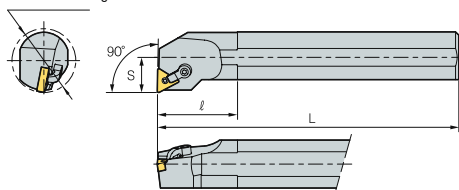

WSP



TN_

(mm)

Bezeichnung	L	R	ØD	Ød	H	L	S	ℓ	Spannflächen	WSP	Klemme	Klemmschraube	Rohrstift	Schlüssel	Zwischenlage
S25T-MTUNR-16		○	32	25	23	300	17	40	-	TN_1604_					
S32U-MTUNR-16		○	40	32	30	350	22	50	-		CDH7N1	DHA10-32-19	SP3D3	"HW19.8L HW23.8L"	-



MVUNR/L

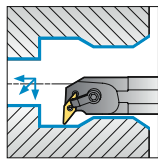

93°

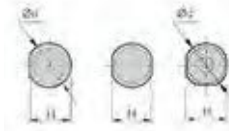
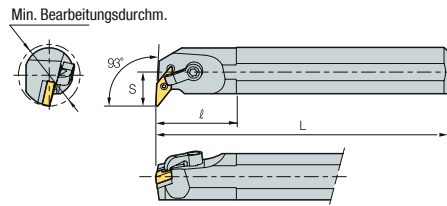

WSP



VN_

(mm)

Bezeichnung	L	R	ØD	Ød	H	L	S	ℓ	Spannflächen	WSP	Klemme	Klemmschraube	Rohrstift	Schlüssel	Zwischenlage
A32S-MVUNR/L-16	○	○	40	32	30	250	22	50	1	VN_1604_					
A40T-MVUNR/L-16	○	○	50	40	37	300	27	55	1						
S32S-MVUNR/L-16	○	○	40	32	30	250	22	50	3						
S32U-MVUNR/L-16	○	○	40	32	30	350	22	50	3						
S40T-MVUNR/L-16	○	○	50	40	37	300	27	55	3						
S40V-MVUNR/L-16		○	50	40	37	400	27	55	3						

MWLNR/L

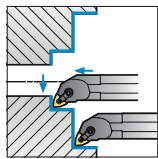

95°

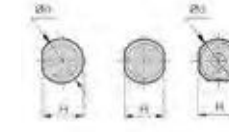
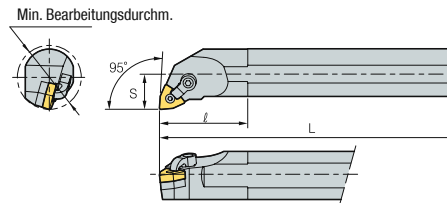

WSP



WN_

(mm)

Bezeichnung	L	R	ØD	Ød	H	L	S	ℓ	Spannflächen	WSP	Klemme	Klemmschraube	Rohrstift	Schlüssel	Zwischenlage
A25R-MWLNR/L-06	○	○	32	25	23	200	17	35	1	WN_0604_					-
A25R-MWLNR/L-08	○	○	32	25	23	200	17	40	1	WN_0804_					-
A32S-MWLNR/L-06	○	○	40	32	30	250	22	35	1	WN_0604_					SW32D
A32S-MWLNR/L-08	○	○	40	32	30	250	22	45	1	WN_0804_					SW43D
S25R-MWLNR/L-06	○	●	32	25	23	200	17	35	3	WN_0604_					-
S25R-MWLNR/L-08	●	●	32	25	23	200	17	40	3	WN_0804_					-
S25T-MWLNR/L-06		○	32	25	23	300	17	35	3	WN_0604_					SW32D
S25T-MWLNR/L-08	○	○	32	25	23	300	17	40	3	WN_0804_					SW43D
S32U-MWLNR/L-06		○	40	32	30	350	22	35	3	WN_0604_					SW32D
S32U-MWLNR/L-08	○	○	40	32	30	350	22	45	3	WN_0804_					SW43D
S32S-MWLNR/L-06	○	○	40	32	30	250	22	35	3	WN_0604_					SW32D
S32S-MWLNR/L-08	○	●	40	32	30	250	22	45	3	WN_0804_					SW43D
S40T-MWLNR/L-06	○	○	50	40	37	300	27	45	3	WN_0604_					SW43D
S40T-MWLNR/L-08	○	●	50	40	37	300	27	52	3	WN_0804_					SW43D
S40V-MWLNR/L-08	○	○	50	40	37	400	27	52	3						SW43D



SCKCR/L

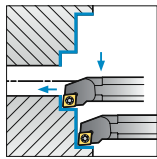

95°

Min. Bearbeitungsdurchm.

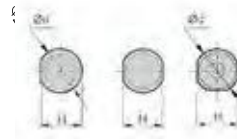
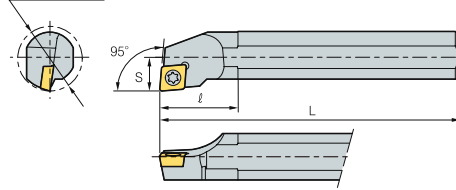

WSP



CC_

Bezeichnung	L	R	ØD	Ød	H	L	S	ℓ	Spannflächen	WSP	Lagenschraube	Schlüssel	Schraube	Zwischenlage
S10K-SCKCL-06	○		12	10	9,5	125	6	14	1	CC_0602_	-	TW07P	FTKA02565	-

SCLCR/L

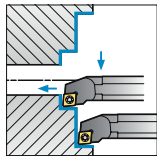

95°

Min. Bearbeitungsdurchm.

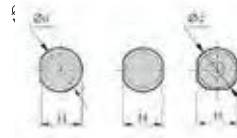
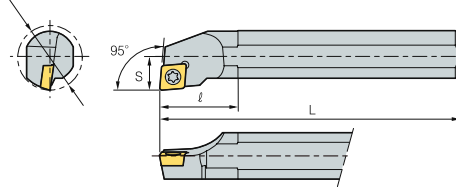

WSP



CC_

Bezeichnung	L	R	ØD	Ød	H	L	S	ℓ	Spannflächen	WSP	Lagenschraube	Schlüssel	Schraube	Zwischenlage
A08F-SCLCR/L-06	▲	▲	10	8	7,5	80	5	14	1	CC_0602_	-	TW07P	FTKA02555	-
A10H-SCLCR/L-06	▲	▲	12	10	9,5	100	6	14	1		-	TW07P	FTKA02565	-
A10M-SCLCR/L-06		▲	12	10	9	150	6	18	1		-	TW07P	FTKA02565	-
A12K-SCLCR/L-06	▲	▲	16	12	11	125	9	25	1		-	TW07P	FTKA02565	-
A12K-SCLCR/L-09	▲	▲	16	12	11	125	9	25	1	CC_09T3_	-	TW15P	FTGA03508	-
A16M-SCLCR/L-09	▲	▲	20	16	15	150	11	32,5	1		-	TW15P	FTGA03508	-
A16Q-SCLCR-09		○	20	16	15	180	11	32,5	1		-	TW15P	FTGA03509	-
A20Q-SCLCR/L-09	▲	▲	25	20	19	180	12		1		-	TW15P	FTGA03508	-
A20Q-SCLCR/L-12		▲	25	20	18	180	13	43	1	CC_1204_	-	TW15P	FTGA0411F	-
A25R-SCLCR/L-09	▲	▲	32	25	24	200	17	45	1	CC_09T3_	-	TW15P	FTGA03510	-
A25R-SCLCR/L-12	▲	▲	32	25	24	200	17	45	1	CC_1204_	-	TW15P	FTGA0411F	-
A32S-SCLCR/L-12	▲	▲	40	32	31	250	32	50	1		SHXN0610F	TW15P HW40L	FTGA0411F	SC42S
A40T-SCLCR/L-12	▲	▲	50	40	37	300	27	61	1		SHXN0610F	TW15P HW40L	FTGA0411F	SC42S
S08K-SCLCR/L-06	▲	▲	10	8	7	125	5	14	2	CC_0602_	-	TW07P	FTKA02555	-
S10K-SCLCR/L-06	▲	▲	12	10	9	125	6	14	3		-	TW07P	FTKA02565	-
S10M-SCLCR/L-06	▲	▲	12	10	9	150	6	14	3		-	TW07P	FTKA02565	-
S12M-SCLCR/L-06	▲	▲	16	12	11	150	9	25	2		-	TW07P	FTKA02565	-
S12M-SCLCR/L-09	▲	▲	16	12	11	150	9	25	2	CC_09T3_	-	TW15P	FTGA03508	-
S16R-SCLCR/L-06	▲	▲	20	16	15	200	11	32	3	CC_0602_	-	TW07P	FTKA02565	-
S16R-SCLCR/L-09	▲	▲	20	16	15	200	11	32,5	3	CC_09T3_	-	TW15P	FTGA03508	-
S20S-SCLCR/L-09	▲	▲	25	20	18	250	13		2		-	TW15P	FTGA03508	-
S20S-SCLCR/L-12		▲	25	20	18	250	13	43	3	CC_1204_	-	TW15P	FTGA0411F	-
S25R-SCLCR/L-09	▲	▲	32	25	23	200	17	45	3	CC_09T3_	-	TW15P	FTGA03510	-
S25R-SCLCR/L-12	▲	▲	32	25	23	200	17	45	3	CC_1204_	-	TW15P	FTGA0411F	-
S25T-SCLCR/L-09	▲	▲	32	25	23	300	17	45	3	CC_09T3_	-	TW15P	FTGA03510	-
S25T-SCLCR/L-12	▲	▲	32	25	23	300	17	45	3	CC_1204_	-	TW15P	FTGA0411F	-
S32S-SCLCR/L-12	▲	▲	40	32	30	250	22	50	3		SHXN0610F	TW15P HW40L	FTGA0411F	SC42S
S32U-SCLCR/L-12	▲	▲	40	32	30	350	22	50	3		SHXN0610F	TW15P HW40L	FTGA0411F	SC42S
S40T-SCLCR/L-12	▲	▲	50	40	37	300	27	60	3		SHXN0610F	TW15P HW40L	FTGA0411F	SC42S
S40V-SCLCR/L-12	▲	▲	50	40	37	400	27	60	3		SHXN0610F	TW15P HW40L	FTGA0411F	SC42S



SCLPR/L

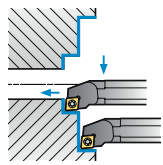

95°

Min. Bearbeitungsdurchm.

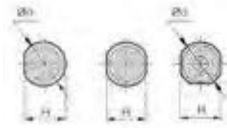
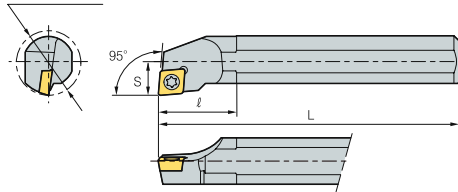

WSP



CP_

Bezeichnung	L	R	ØD	Ød	H	L	S	ℓ	Spannflächen	WSP	(mm)	
											Schlüssel	Schraube
A10H-SCLPR/L-08	▲	○	12	10	9,5	100	6	23	1	CP__0802__	TW09P	FTNA0305
A12K-SCLPR/L-08	○	▲	16	12	11	125	8	20	1		TW09P	FTNA0305
A16M-SCLPR/L-09	○	○	20	16	15	150	10	25	1	CP__0903__	TW15P	FTNA0408
A20Q-SCLPR/L-09	▲	○	25	20	19	180	12,5	28	1		TW15P	FTNA0408
S10M-SCLPR/L-08	○	●	12	10	9	150	6	18	3	CP__0802__	TW09P	FTNA0305
S12M-SCLPR/L-08	▲	●	16	12	11	150	9	20	2		TW09P	FTNA0305
S16N-SCLPR/L-09	○	●	20	16	15	160	10	25	3	CP__0903__	TW15P	FTNA0408
S16R-SCLPR/L-09	○	●	20	16	15	200	11	35	3		TW15P	FTNA0407
S20N-SCLPR/L-09	○	▲	25	20	18	160	12,5	25	2		TW15P	FTNA0408
S20S-SCLPR/L-09	○	▲	25	20	15	250	12,5	28	3		TW15P	FTNA0407

SDQCR/L

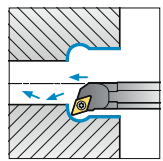

107,5°

Min. Bearbeitungsdurchm.

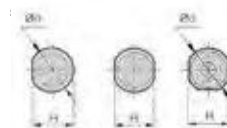
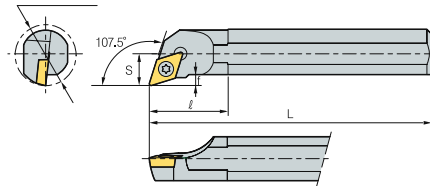

WSP



DC_

Bezeichnung	L	R	ØD	Ød	H	L	S	ℓ	f	Spannflächen	WSP	(mm)			
												Lagenschraube	Schlüssel	Schraube	Zwischenlage
A10H-SDQCR/L-07	▲	▲	13	10	9,5	100	7	20	2	1	DC__0702__	-	TW07P	FTKA02555	-
A12K-SDQCR/L-07	▲	▲	16	12	11	125	9	22	3	1		-	TW07P	FTKA02565	-
A16M-SDQCR/L-11	▲	▲	20	16	15	150	11	27	3	1	DC__11T3__	-	TW15P	FTGA03508	-
A16M-SDQCR/L-07		▲	20	16	15	150	11	27	3	1	DC__0702__	-	TW07P	FTKA02565	-
A20Q-SDQCR/L-11	▲	▲	25	20	19	180	13	32	3	1	DC__11T3__	-	TW15P	FTGA03508	-
A25R-SDQCR/L-11	▲	▲	32	25	24	200	17	32	4	1		-	TW15P	FTGA03510	-
S10M-SDQCR/L-07	▲	▲	13	10	9	150	7	20	2,5	3	DC__0702__	-	TW07P	FTKA02555	-
S12M-SDQCR/L-07	▲	▲	16	12	11	150	9	22	3,5	3		-	TW07P	FTKA02565	-
S16R-SDQCR/L-07	▲	▲	20	16	15	200	11	27	4	3		-	TW07P	FTKA02565	-
S16R-SDQCR/L-11	▲	▲	20	16	15	200	11	32	4	3	DC__11T3__	-	TW15P	FTGA03508	-
S20S-SDQCR/L-11	▲	▲	25	20	18	250	13	32	4,5	3		-	TW15P	FTGA03508	-
S25R-SDQCR/L-11	▲	▲	32	25	23	200	17	32	7	3		-	TW15P	FTGA03510	-
S25T-SDQCR/L-11	▲	▲	32	25	23	300	17	32	7	3		-	TW15P	FTGA03510	-
S32S-SDQCR/L-11	▲	▲	40	32	30	250	22	40	10	3		-	TW15P	FTGA03510	-
S50W-SDQCR/L-11		▲	63	50	47	450	35	62	12,5	3		SHXN0509F	TW15P HW35L	FTGA03512	SD32S



SDUCR/L

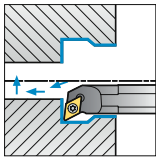

93°

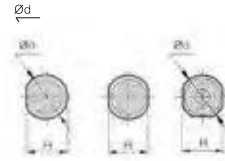
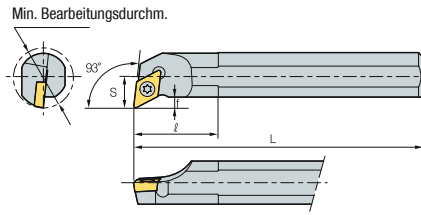

WSP



DC_

(mm)

Bezeichnung	L	R	ØD	Ød	H	L	S	ℓ	f	Spannflächen	WSP	Lagenschraube	Schlüssel	Schraube	Zwischenlage
A10H-SDUCR/L-07	▲	▲	13	10	9,5	100	7	20	2	1	DC__0702__	-	TW07P	FTKA02555	-
A12K-SDUCR/L-07	▲	▲	16	12	11	125	9	22	3	1		-	TW07P	FTKA02565	-
A16M-SDUCR/L-07	▲	▲	20	16	15	150	11	27	3	1		-	TW07P	FTKA02565	-
A16R-SDUCR/L-07		▲	20	16	15	200	11	27	3	1		-	TW07P	FTKA02565	-
A20Q-SDUCR/L-11	▲	▲	25	20	19	180	13	35	3	1	DC__11T3__	-	TW15P	FTGA03508	-
A25R-SDUCR/L-11	▲	▲	32	25	24	200	17	46	4,5	1		-	TW15P	FTGA03510	-
A25T-SDUCR/L-11		▲	32	25	23	300	17	46	4,5	1		-	TW15P	FTGA03510	-
A32U-SDUCR/L-11	▲	▲	40	32	30	350	22	40	10	3		-	TW15P	FTGA03510	-
A40T-SDUCR/L-11	▲	▲	50	40	37	300	27	50	7	1	SHXN0509F	TW15P HW35L	FTGA03512	SD32S	
A40V-SDUCR-11		○	50	40	37	400	27	50	9	3		SHXN0509F	TW15P HW35L	FTGA03512	SD32S
S10M-SDUCR/L-07	▲	▲	13	10	9	150	7	20	2,5	3	DC__0702__	-	TW07P	FTKA02555	-
S12M-SDUCR/L-07	▲	▲	16	12	11	150	9	22	3,5	3	DC__11T3__	-	TW07P	FTKA02565	-
S16Q-SDUCR/L-11	▲	▲	20	16	15	180	11	27	4	3		-	TW15P	FTGA03508	-
S16R-SDUCR/L-07	▲	▲	20	16	15	200	11	27	4	3	DC__0702__	-	TW07P	FTKA02565	-
S16R-SDUCR/L-11	▲	▲	20	16	15	200	11	27	4	3	DC__11T3__	-	TW15P	FTGA03508	-
S20R-SDUCR/L-11		▲	25	20	18	200	13	40	4,5	3	-	TW15P	FTGA03508	-	
S20S-SDUCR/L-07		▲	25	20	18	250	13	29	4,5	3	DC__0702__	-	TW07P	FTKA02565	-
S20S-SDUCR/L-11	▲	▲	25	20	18	250	13	40	4,3	3	DC__11T3__	-	TW15P	FTGA03508	-
S25R-SDUCR/L-11	▲	▲	32	25	23	200	17	40	6	3		-	TW15P	FTGA03510	-
S25T-SDUCR/L-11	▲	▲	32	25	23	300	17	40	6	3		-	TW15P	FTGA03510	-
S32S-SDUCR/L-11	▲	▲	40	32	30	250	22	40	10	3		-	TW15P	FTGA03510	-
S32U-SDUCR/L-11	▲	▲	40	32	30	350	22	40	10	3	-	TW15P	FTGA03510	-	
S40T-SDUCR/L-11	○		50	40	37	300	27	50	9	3	SHXN0509F	TW15P HW35L	FTGA03512	SD32S	
S40V-SDUCR/L-11		▲	50	40	37	400	27	50	9	3		SHXN0509F	TW15P HW35L	FTGA03512	SD32S
S50W-SDUCR/L-11	○	▲	63	50	47	450	35	55	12,5	3	-	TW15P	FTGA03510	-	



SDZCR/L

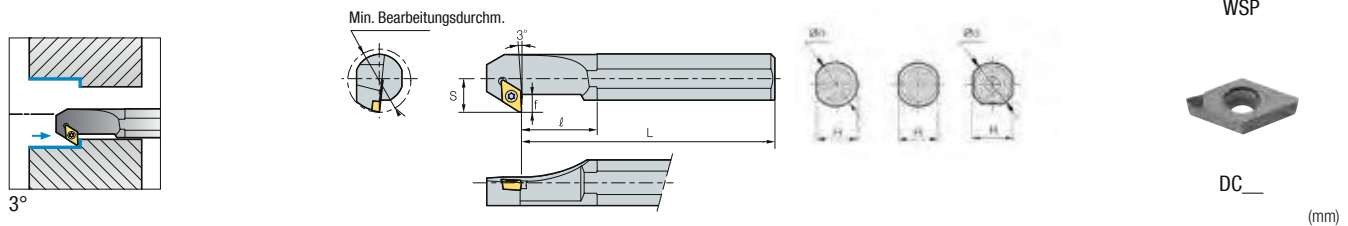

Bezeichnung	L	R	ØD	Ød	H	L	S	ℓ	f	Spannflächen	WSP	Lagenschraube	Schlüssel	Schraube	Zwischenlage
A25R-SDZCR/L-11	○	○	32	25	24	200	17	30	4,5	1	DC_11T3_	-	TW15P	FTGA03510	-
A32S-SDZCR/L-11	○	▲	40	32	31	250	22	45	11	1		SHXN0509F	TW15P HW35L	FTGA03512	SD32S
S16R-SDZCR/L-07	▲	▲	20	16	15	200	11	20	4	3	DC_0702_	-	TW07P	FTKA02565	-
S20S-SDZCR/L-07	○	▲	25	20	18	250	13	25	4,5	3		-	TW07P	FTKA02565	-
S25R-SDZCR/L-11	▲	▲	32	25	23	200	17	30	6,9	3	DC_11T3_	-	TW15P	FTGA03510	-
S25T-SDZCR/L-11	▲	▲	32	25	23	300	17	38	9	3		-	TW15P	FTGA03510	-
S32S-SDZCR/L-11	▲	▲	40	32	30	250	22	45	11	3		SHXN0509F	TW15P HW35L	FTGA03512	SD32S
S32U-SDZCR/L-11	○	○	40	32	30	350	22	45	11	3		SHXN0509F	TW15P HW35L	FTGA03512	SD32S
S40T-SDZCR/L-11	○	▲	50	40	37	300	27	55	11	3		SHXN0509F	TW15P HW35L	FTGA03512	SD32S
S40V-SDZCR/L-11	▲		50	40	37	400	27	55	11	3		SHXN0509F	TW15P HW35L	FTGA03512	SD32S

SSKCR/L

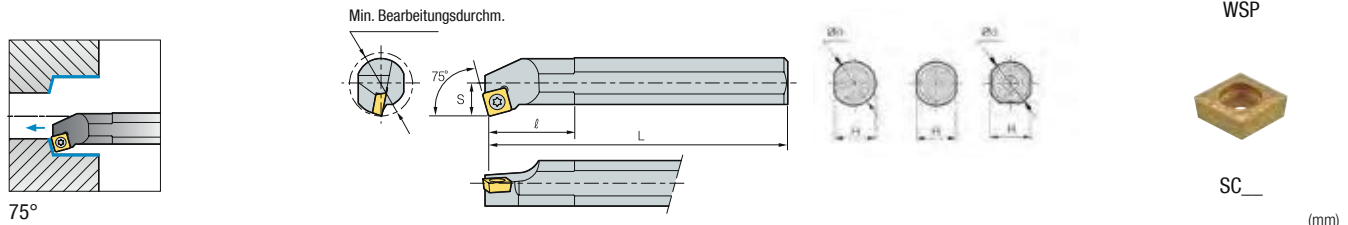

Bezeichnung	L	R	ØD	Ød	H	L	S	ℓ	Spannflächen	WSP	Lagenschraube	Schlüssel	Schraube	Zwischenlage
A12K-SSKCR/L-09	○	○	16	12	11	125	9	25	1	SC_09T3_	-	TW15P	FTGA03507	-
A16M-SSKCR/L-09	○	▲	20	16	15	150	11	32	1		-	TW15P	FTGA03508	-
A20Q-SSKCR/L-09	▲	▲	25	20	19	180	12	34	1		-	TW15P	FTGA03508	-
A25R-SSKCR/L-12	○	▲	32	25	24	200	17	41	1	SC_1204_	-	TW15P	FTGA0411F	-
A32S-SSKCR/L-12	○	○	40	32	31	250	22	43	1		SHXN0610F	TW15P HW40L	FTGA0411F	SS42S
S12M-SSKCR/L-09	▲	●	16	12	11	150	9	26	3	SC_09T3_	-	TW15P	FTGA03507	-
S16R-SSKCR/L-09	○	▲	20	16	15	200	11	32	3		-	TW15P	FTGA03508	-
S20S-SSKCR/L-09	○	▲	25	20	18	250	13	34	3		-	TW15P	FTGA03508	-
S25R-SSKCR/L-12	○	▲	32	25	23	200	17	36	3	SC_1204_	-	TW15P	FTGA0411F	-
S25T-SSKCR/L-12	○	○	32	25	23	300	17	45	3		-	TW15P	FTGA0411F	-
S32S-SSKCR/L-12	▲	●	40	32	30	250	22	43	3		SHXN0610F	TW15P HW40L	FTGA0411F	SS42S
S32U-SSKCR/L-12	○	○	40	32	30	350	22	43	3		SHXN0610F	TW15P HW40L	FTGA0411F	SS42S



SSSCR/L

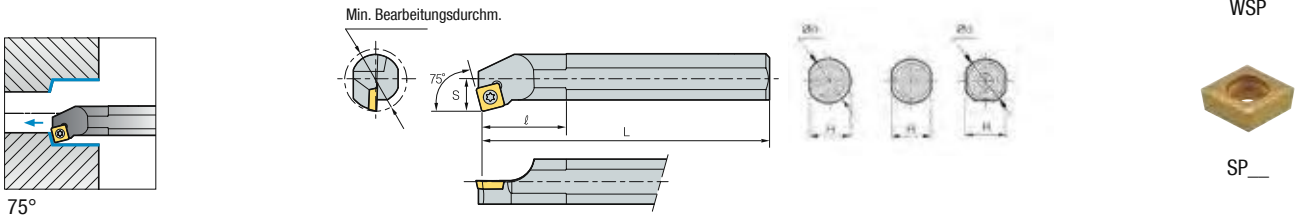

Bezeichnung	L	R	ØD	Ød	H	L	S	ℓ	Spannflächen	WSP	Schlüssel	Schraube	Zwischenlage
A25T-SSSCR-09		▲	32	25	23	300	17	45	-	TC_0902_	TC_0902_	FTNA0305	-

(mm)

SSKPR/L

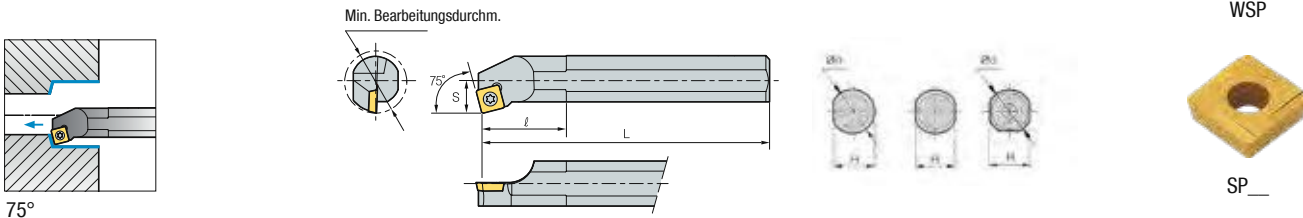

Bezeichnung	L	R	ØD	Ød	H	L	S	ℓ	Spannflächen	WSP	Schlüssel	Schraube
A12K-SSKPR/L-09	○	○	16	12	11	125	8	21	1	SP__0903__	TW09P	FTNA0305
A16M-SSKPR/L-09	○	○	20	16	15	150	10	30	1		TW09P	FTNA0307
A20Q-SSKPR/L-09	○	○	25	20	19	180	12,5	32	1		TW09P	FTNA0307
S12M-SSKPR/L-09	▲	▲	16	12	11	150	8	18	3		TW09P	FTNA0307
S16N-SSKPR/L-09	●	○	20	16	15	160	10	30	3		TW09P	FTNA0307
S16R-SSKPR/L-09	○	●	20	16	15	200	10	32	3		TW09P	FTNA0307
S20N-SSKPR/L-09	●	▲	25	20	18	160	12,5	32	3		TW09P	FTNA0307
S20S-SSKPR/L-09	○	●	25	20	18	250	12,5	35	3		TW09P	FTNA0307

(mm)



STFCR/L

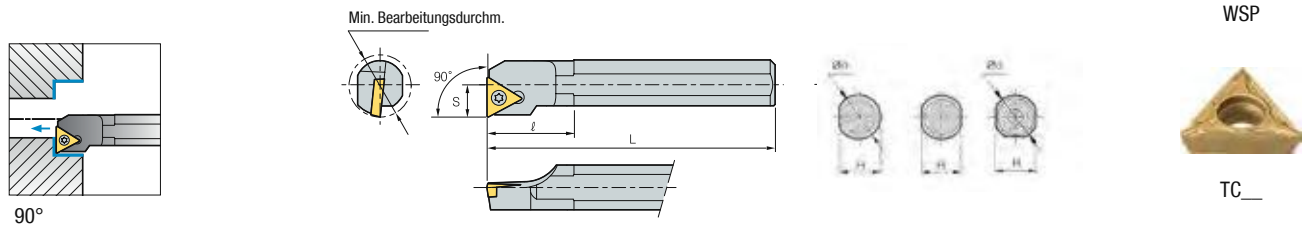

Bezeichnung	L	R	ØD	Ød	H	L	S	ℓ	Spannflächen	WSP	Lagerschraube	Schlüssel	Schraube	Zwischenlage
A10H-STFCR/L-09	○	▲	13	10	9,5	100	7	23	1	TC_0902_	-	TW06P	FTKA02206	-
A12K-STFCR/L-09	○	▲	16	12	11	125	9	23	1	TC_1102_	-	TW06P	FTKA02206	-
A12K-STFCR/L-11	▲	▲	16	12	11	125	9	30	1		-	TW06P	FTKA02206	-
A16M-STFCR/L-11	▲	▲	20	16	15	150	11	35	1	TC_16T3_	-	TW07P	FTKA02565	-
A16R-STFCR/L-16		▲	20	16	15	200	11	40	1		-	TW07P	FTKA02565	-
A20Q-STFCR/L-11	○	▲	25	20	19	180	13	36	1	TC_1102_	-	TW07P	FTKA02565	-
A20R-STFCR/L-16		▲	25	20	18	200	13	40	1		-	TW07P	FTKA02565	-
A25R-STFCR/L-16	▲	▲	32	25	24	200	17	49	1	TC_16T3_	-	TW15P	FTKA03510	-
A32S-STFCR/L-16	▲	▲	40	32	31	250	22	50	1		SHXN0509F	TW15P HW35L	FTGA03512	ST32S
A40T-STFCR/L-16		○	50	40	37	300	27	60	1	TC_1102_	SHXN0509F	TW15P HW35L	FTGA03512	ST32S
S10M-STFCR/L-09	▲	▲	13	10	9	150	7	23	3		-	TW06P	FTKA02206	-
S12M-STFCR/L-09	▲	▲	16	12	11	150	9	28	3	TC_1102_	-	TW06P	FTKA02206	-
S12M-STFCR/L-11	▲	▲	16	12	11	150	9	30	3		-	TW07P	FTKA02565	-
S16R-STFCR/L-11	▲	▲	20	16	15	200	11	35	3	TC_16T3_	-	TW07P	FTKA02565	-
S20S-STFCR/L-11	●	▲	25	20	18	250	13	36	3		-	TW07P	FTKA02565	-
S20S-STFCR/L-16	▲	▲	25	20	18	250	13	40	3	TC_1102_	-	TW15P	FTGA03510	-
S25R-STFCR/L-16	▲	▲	32	25	23	200	17	49	3		-	TW15P	FTGA03510	-
S25T-STFCR/L-16	▲	▲	32	25	23	300	17	40	3	TC_16T3_	-	TW07P	FTKA02565	-
S32S-STFCR/L-16	○	▲	40	32	30	250	22	50	3		SHXN0509F	TW15P HW35L	FTGA03512	ST32S
S32U-STFCR/L-16	▲	▲	40	32	30	350	22	50	3	TC_1102_	SHXN0509F	TW15P HW35L	FTGA03512	ST32S
S40T-STFCR/L-16	○	▲	50	40	37	300	27	60	3		SHXN0509F	TW15P	FTGA03512	ST32S
S40V-STFCR/L-16		▲	50	40	37	400	27	60	3	SHXN0509F	TW15P HW35L	FTGA03512	ST32S	

STFPR/L

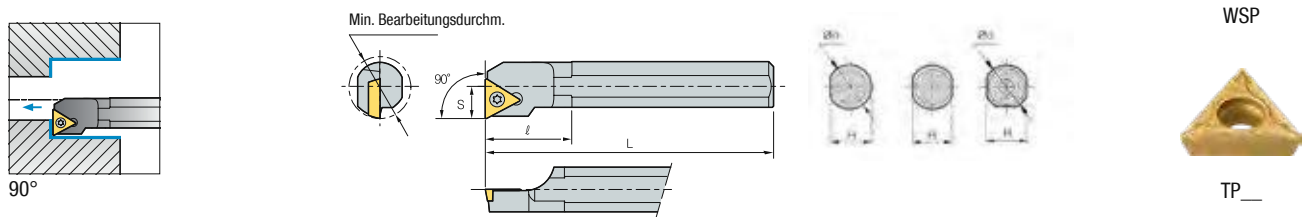

Bezeichnung	L	R	ØD	Ød	H	L	S	ℓ	Spannflächen	WSP	Schlüssel	Schraube
A10H-STFPR/L-11	○	○	12	10	9,5	100	6	30	1	TP_1103_	TW09P	FTNA0305
A12K-STFPR/L-11	○	○	16	12	11	125	8	30	1		TW09P	FTNA0307
A16M-STFPR/L-11	▲	▲	20	16	15	150	10	33	1		TW09P	FTNA0307
A20Q-STFPR/L-16	○	○	25	20	19	180	12,5	41	1	TP_1604_	TW15P	FTNA0408
S10M-STFPR/L-11	▲	▲	12	10	9	150	6	24	2		TP_1103_	TW09P
S12M-STFPR/L-11	▲	▲	16	12	11	150	8	-	2	TW09P		FTNA0307
S16N-STFPR/L-11	○	●	20	16	15	160	10	-	2	TW09P		FTNA0307
S16R-STFPR/L-11	●	▲	20	16	15	200	10	33	2	TP_1604_	TW09P	FTNA0307
S20N-STFPR/L-16	○	●	25	20	18	160	12,5	32	2		TW15P	FTNA0408
S20S-STFPR/L-16	○	●	25	20	18	250	12,5	32	2	TW15P	FTNA0408	

▲: Lagerartikel Europa ●: Lagerartikel Korea ○: Lieferzeit auf Anfrage



STUBR/L

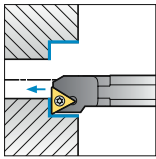

90°

Min. Bearbeitungsdurchm.

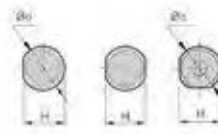
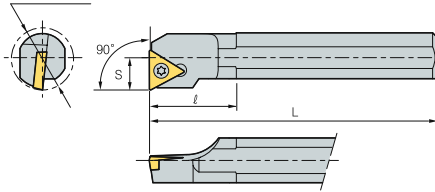

WSP



TB_

(mm)

Bezeichnung	L	R	ØD	Ød	H	L	S	ℓ	Spannflächen	WSP	Lagenschraube	Schlüssel	Schraube	Zwischenlage
A08F-STUBR/L-06	▲	▲	8	8	7,5	80	4	30	1	TB_0601_R/L	-	TW06P	FTNA0204	-
S08K-STUBR/L-06	▲	▲	8	8	7	125	4	30	2			TW06P	FTNA0204	

STUPR/L

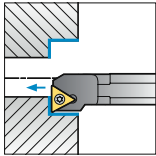

90°

Min. Bearbeitungsdurchm.

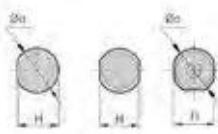
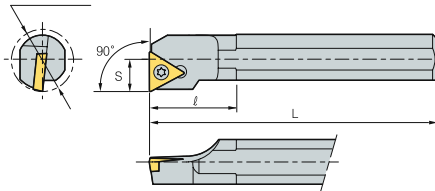

WSP



TP_

(mm)

Bezeichnung	L	R	ØD	Ød	H	L	S	ℓ	Spannflächen	WSP	Lagenschraube	Schlüssel	Schraube	Zwischenlage
A08F-STUPR/L-08	▲	▲	10	8	7,5	80	5	18	1	TP_0802_R/L	-	TW06P	FTNA02205	-
S08K-STUPR/L-08	▲	▲	10	8		125	5	18	2			TW06P	FTNA02205	



STWPR/L

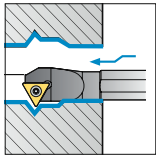

60°

Min. Bearbeitungsdurchm.

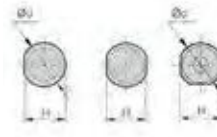
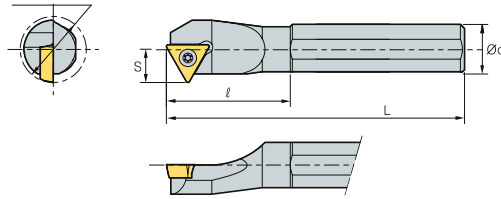

WSP



TP_

(mm)

Bezeichnung	L	R	ØD	Ød	H	L	S	ℓ	Spannflächen	WSP	Schlüssel	Schraube
S10M-STWPR/L-11	▲	▲	12	10	9	150	6	23	3	TP_1103_	TW09P	FTNA0305
S12M-STWPR/L-11	▲	▲	16	12	11	150	8	30	3		TW09P	FTNA0306
S16Q-STWPR/L-11		●	20	16	15	180	10	35	3		TW09P	FTNA0306
S16R-STWPR/L-11	○	▲	20	16	15	180	10	35	3		TW09P	FTNA0306
S20R-STWPR/L-11	▲	▲	25	20	19	200	12,5	40	3		TW09P	FTNA0306

SVJCR/L

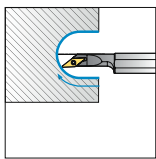

142°

Min. Bearbeitungsdurchm.

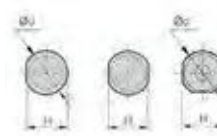
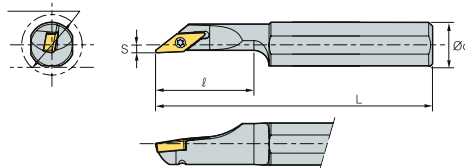

WSP



VCMT

(mm)

Bezeichnung	L	R	ØD	Ød	H	L	S	ℓ	Spannflächen	WSP	Schlüssel	Schraube
S12M-SVJCR/L-08	▲	▲	16	12	11	150	2	26	3	VCMT0802_	TW06P	FTNA0204
S16Q-SVJCR/L-08	▲	▲	20	16	15	180	2	36	3		TW06P	FTNA0204



SVQBR/L

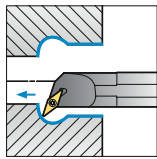

108°

Min. Bearbeitungsdurchm.

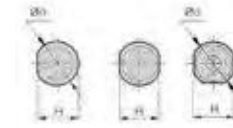
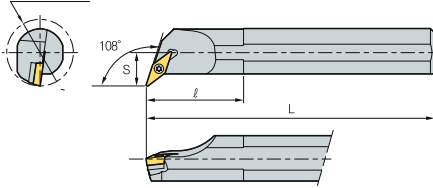

WSP



VB_

(mm)

Bezeichnung	L	R	ØD	Ød	H	L	S	ℓ	Spannflächen	WSP	Lagenschraube	Schlüssel	Schraube	Zwischenlage
A16R-SVQBR/L-11	○		20	16	15	200	11	27	1	VB_1102_	-	TW07P	FTKA02565	-
A32S-SVQBR/L-16	▲	▲	40	32	31	250	22	56	1	VB_1604_	SHXN0509F	TW15P HW35L	FTGA03512	SV32S
S32S-SVQBR/L-16	▲	▲	40	32	30	250	22	56	3		SHXN0509F	TW15P HW35L	FTGA03512	SV32S
S40T-SVQBR/L-16	▲	▲	50	40	37	300	27	64	3		SHXN0509F	TW15P HW35L	FTGA03512	SV32S
S40V-SVQBR/L-16		▲	50	40	37	400	27	64	3		SHXN0509F	TW15P HW35L	FTGA03512	SV32S



SVQCR/L

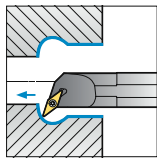

108°

Min. Bearbeitungsdurchm.

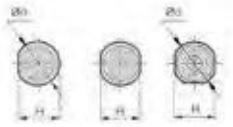
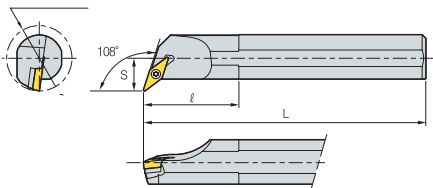

WSP



VC_

(mm)

Bezeichnung	L	R	ØD	Ød	H	L	S	ℓ	Spannflächen	WSP	Lagenschraube	Schlüssel	Schraube	Zwischenlage
A16M-SVQCR/L-11	▲	▲	16	12	11	125	8	30	1	VB_1102_	-	TW09P	FTNA0307	-
A20Q-SVQCR/L-11	▲	▲	25	20	18	180	13	35	1		-	TW07P	FTKA02565	-
A20Q-SVQCR/L-13	○	▲	25	20	18	180	13	42	3	VC_1303_	-	TW09P	FTGA0307	-
A25R-SVQCR/L-11	▲	▲	32	25	23	200	17	35	3	VC_1103_	-	TW07P	FTKA02565	-
A25R-SVQCR/L-13	○	○	32	25	23	200	17	45	3	VC_1303_	-	TW09P	FTNA0307	-
A25R-SVQCR/L-16	▲	▲	32	25	23	200	17	40	3	VC_1604_	-	TW15P	FTGA03510	-
A32S-SVQCR/L-16	▲	▲	40	32	30	250	22	45	3		SHXN0509F	TW15P HW35L	FTGA03512	SV32S
A40T-SVQCR/L-16	▲	▲	50	40	37	300	27	64	3	SHXN0509F	TW15P HW35L	FTGA03512	SV32S	
S16R-SVQCR/L-11	▲	▲	20	16	15	200	11	35	3	VC_1103_	-	TW07P	FTKA02565	-
S20S-SVQCR/L-11	▲	▲	25	20	18	250	13	38	3	-	TW07P	FTKA02565	-	
S20S-SVQCR/L-13	○	●	25	20	18	250	13	42	3	VC_1303_	-	TW09P	FTGA0307	-
S25R-SVQCR/L-11	▲	○	32	25	23	200	17	35	3	VC_1103_	-	TW07P	FTKA02565	-
S25R-SVQCR/L-13	○	○	32	25	23	200	17	45	3	VC_1303_	-	TW09P	FTNA0307	-
S25R-SVQCR/L-16	▲	▲	32	25	23	200	17	40	3	VC_1604_	-	TW15P	FTGA03510	-
S25T-SVQCR/L-16	▲	○	32	25	23	300	17	40	3		-	TW15P HW35L	FTGA03510	-
S32S-SVQCR/L-16	▲	▲	40	32	30	250	22	45	3	SHXN0509F	TW15P HW35L	FTGA03512	SV32S	
S32U-SVQCR/L-16	○	▲	40	32	30	350	22	56	3	SHXN0509F	TW15P HW35L	FTGA03512	SV32S	
S40T-SVQCR/L-16	▲	▲	50	40	37	300	27	64	3	SHXN0509F	TW15P HW35L	FTGA03512	SV32S	



SVUBR/L

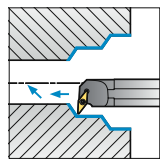

93°

Min. Bearbeitungsdurchm.

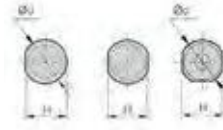
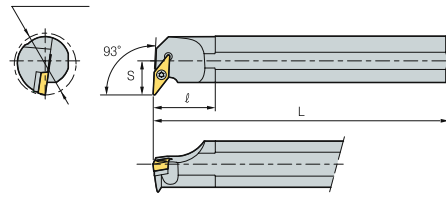

WSP



VB_

Bezeichnung	L	R	ØD	Ød	H	L	S	ℓ	Spannflächen	WSP	Lagenschraube	Schlüssel	Schraube	Zwischenlage
A25T-SVUBR/L-11	○		32	25	23	300	17	30	1	VB_1102_	-	TW07P	FTKA02565	-
A32S-SVUBR/L-16	▲	▲	40	32	31	250	22	49	1	VB_1604_	SHXN0509F	TW15P HW35L	FTGA03512	SV32S
S25T-SVUBR/L-16		▲	32	25	23	300	17	40	3		SHXN0509F	TW15P HW35L	FTGA03512	SV32S
S32S-SVUBR/L-16	▲	▲	40	32	30	250	22	40	3		SHXN0509F	TW15P HW35L	FTGA03512	SV32S
S32U-SVUBR/L-16	○	▲	40	32	30	350	22	40	3		SHXN0509F	TW15P HW35L	FTGA03512	SV32S
S40T-SVUBR/L-16	▲	▲	50	40	37	300	27	50	3		SHXN0509F	TW15P HW35L	FTGA03512	SV32S
S40V-SVUBR/L-16	○	○	50	40	37	400	27	50	3		SHXN0509F	TW15P HW35L	FTGA03512	SV32S

(mm)

SVUCR/L

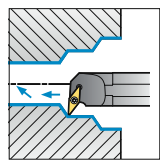

93°

Min. Bearbeitungsdurchm.

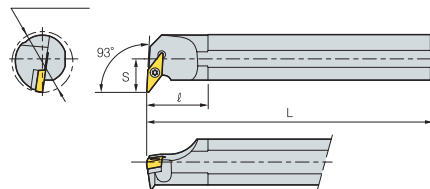

WSP



VC_

Bezeichnung	L	R	ØD	Ød	H	L	S	ℓ	Spannflächen	WSP	Lagenschraube	Schlüssel	Schraube	Zwischenlage
A40T-SVUCR/L-16	▲	▲	50	40	37	300	27	43	1	VC_1604_	SHXN0509F	TW15P HW35L	FTGA03512	SV32S
S16R-SVUCR/L-11	▲	▲	22	16	15	200	13	30	3	VC_1103_	-	TW07P	FTKA02565	-
S20S-SVUCR/L-11	▲	▲	25	20	18	250	14	33	3		TW07P	FTKA02565	-	-
S20S-SVUCR/L-13	▲	▲	28	20	18	250	16	35	3	VC_1303_	-	TW09P	FTKA0307	-
S25R-SVUCR/L-13	▲	▲	32	25	23	200	17	40	3		TW09P	FTKA0307	-	-
S25R-SVUCR/L-16	▲	▲	32	25	23	200	19	50	3	VC_1604_	-	TW15P	FTGA03510	-
S25T-SVUCR/L-11	▲	▲	32	25	23	300	17	38	3	VC_1103_	-	TW07P	FTKA02565	-
S25T-SVUCR/L-16	▲	▲	32	25	23	300	19	50	3	VC_1604_	-	TW15P	FTGA03510	-
S32S-SVUCR/L-16	▲	▲	40	32	30	250	22	56	3		SHXN0509F	TW15P HW35L	FTGA03512	SV32S
S32U-SVUCR/L-16	▲	▲	40	32	30	350	22	56	3		SHXN0509F	TW15P HW35L	FTGA03512	SV32S
S40T-SVUCR/L-16	▲	▲	50	40	37	300	27	64	3		SHXN0509F	TW15P HW35L	FTGA03512	SV32S
S40V-SVUCR/L-16	○	○	50	40	37	400	27	64	3		SHXN0509F	TW15P HW35L	FTGA03512	SV32S

(mm)



SWLCR/L

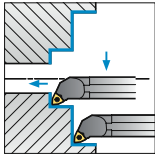

95°

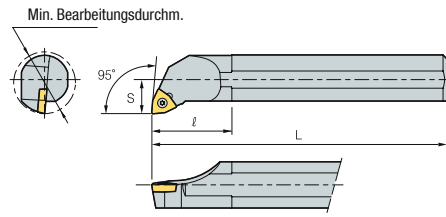

WSP



WC_

(mm)

Bezeichnung	L	R	ØD	Ød	H	L	S	ℓ	Spannflächen	WSP	Schlüssel	Schraube
A25R-SWLCR/L-08	○	▲	32	25	24	200	17	46	1	WC_0804_	TW15P	FTGA0411F
S25R-SWLCR/L-08	○	○	32	25	23	200	17	46	3		TW15P	FTGA0411F
S25T-SWLCR/L-08	○	○	32	25	23	300	17	38	3		TW15P	FTGA0411F
A32S-SWLCR/L-08		▲	40	32	31	250	22	51	1		TW15P	FTGA0411F
S32S-SWLCR/L-08	○	○	40	32	30	250	22	51	3		TW15P	FTGA0411F
S32U-SWLCR/L-08		▲	40	32	30	350	22	51	3		TW15P	FTGA0411F



SCLCR/L

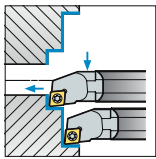

95°

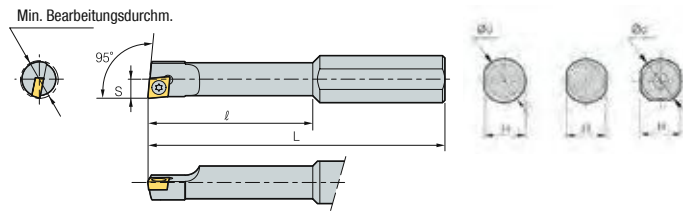

WSP



CCET

Bezeichnung	L	R	ØD	Ød	H	L	S	ℓ	Spannflächen	WSP	(mm)	
											Schlüssel	Schraube
S10H-SCLCR/L-0305	▲	▲	5	10	9	100	2,5	25	2	CCET0301_	TW06P	FTNA01633
S10H-SCLCR/L-0306	○	▲	6	10	9	100	3	25	2		TW06P	FTNA01633
S10J-SCLCR/L-0407	○	▲	7	10	9	110	3,5	30	2	CCET0401_	TW06P	FTNA0238
S10J-SCLCR/L-0408	○	▲	8	10	9	110	4	30	2		TW06P	FTNA0238

STUBR/L

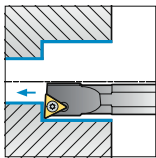

93°

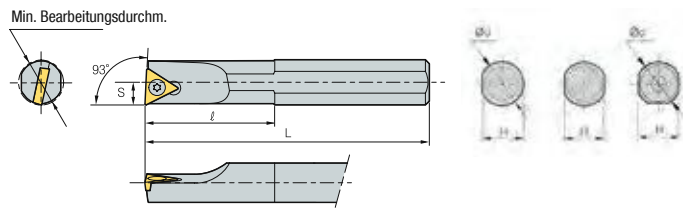

WSP



TB_

Bezeichnung	L	R	ØD	Ød	H	L	S	ℓ	Spannflächen	WSP	(mm)	
											Schlüssel	Schraube
A08F-STUBR/L-06	▲	▲	8	8	7,5	80	4	30	1	TB_0601_R/L	TW06P	FTNA0204
S08K-STUBR/L-06	▲	▲	8	8	7	125	4	30	2		TW06P	FTNA0204

• Halter entgegengesetzt zur Richtung der Schneidplatte



STUPR/L

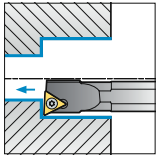

93°

Min. Bearbeitungsdurchm.

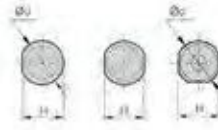
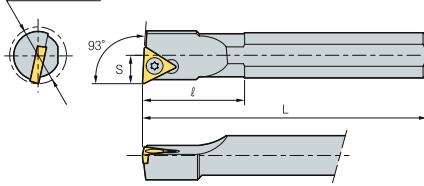

WSP



TP_

(mm)

Bezeichnung	L	R	ØD	Ød	H	L	S	ℓ	Spannflächen	WSP	Schlüssel	Schraube
A08F-STUPR/L-08	○	○	10	8	7,5	80	5	18	1	TP_0802_R/L	TW06P	FTNA02205
S08K-STUPR/L-08	▲	▲	10	8	7	125	5	18	2		TW06P	FTNA02205

SWUBR/L

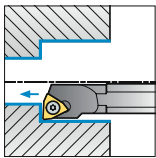

93°

Min. Bearbeitungsdurchm.

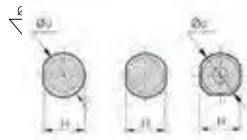
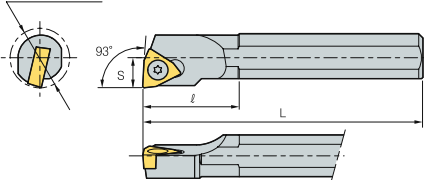

WSP



WBG

(mm)

Bezeichnung	L	R	ØD	Ød	H	L	S	ℓ	Spannflächen	WSP	Schlüssel	Schraube
A08F-SWUBR/L-S3	○	○	10	8	7,5	80	5	16	1	WBGTS302_R/L	TW06P	FTNA02205
S08K-SWUBR/L-S3	○	▲	10	8	7	125	5	16	3		TW06P	FTNA02205
S05H-SWUBR/L-02	▲	▲	5,5	5	4,5	100	2,75	-	2	WBG0201_R/L	TW06P	FTNA0203
A08F-SWUBR/L-02	▲	▲	8	8	7,5	80	4	30	1		TW06P	FTNA0203
S08K-SWUBR/L-02	○	○	8	8	7	125	4	30	2		TW06P	FTNA02033



SCLCR/L

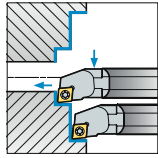

95°

Min. Bearbeitungsdurchm.

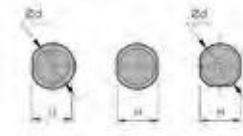
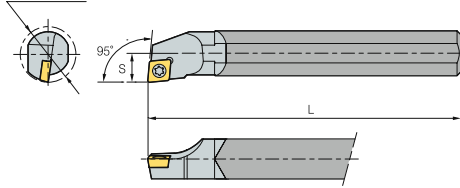

WSP



CC_

(mm)

Bezeichnung	L	R	ØD	Ød	H	L	S	Spannflächen	WSP	Schlüssel	Schraube	
C08K-SCLCR/L-06	▲	▲	10	8	7	125	5	2	CC_T0602_	TW07P	FTKA02555	
E08K-SCLCR/L-06	▲	▲	10	8	7	125	5	2		TW07P	FTKA02555	
C10K-SCLCR/L-06	▲	▲	12	10	9	125	6	2		TW07P	FTKA02565	
C10M-SCLCR/L-06	▲	▲	12	10	9	150	6	2		TW07P	FTKA02565	
E10K-SCLCR/L-06	▲	▲	12	10	9	125	6	2		TW07P	FTKA02565	
E10M-SCLCR/L-06	▲	▲	12	10	9	150	6	2		TW07P	FTKA02565	
C12M-SCLCR/L-06	▲	▲	14	12	11	150	7	2		TW07P	FTKA02565	
C12Q-SCLCR/L-06	○	▲	14	12	11	180	7	2		TW07P	FTKA02565	
E12M-SCLCR/L-06	▲	▲	14	12	11	150	7	2		TW07P	FTKA02565	
E12Q-SCLCR/L-06	▲	▲	14	12	11	180	7	2		TW07P	FTKA02565	
C12M-SCLCR/L-09	▲	▲	15	12	11	150	8	2		CC_T09T3_	TW15P	FTGA03508
C12Q-SCLCR/L-09	○	▲	15	12	11	180	8	2			TW15P	FTGA03508
E12M-SCLCR/L-09	▲	▲	15	12	11	150	8	2	TW15P		FTGA03508	
E12Q-SCLCR/L-09	▲	▲	15	12	11	180	8	2	TW15P		FTGA03508	
C16R-SCLCR/L-09	▲	▲	20	16	15	200	10	2	TW15P		FTGA03508	
C16S-SCLCR/L-09	○	▲	20	16	15	250	10	2	TW15P		FTGA03508	
E16R-SCLCR/L-09	▲	▲	20	16	15	250	10	2	TW15P		FTGA03508	
E16S-SCLCR/L-09	▲	▲	20	16	15	250	10	2	TW15P		FTGA03508	
C20R-SCLCR/L-09	▲	▲	25	20	18	200	13	2	TW15P		FTGA03508	
C20S-SCLCR/L-09	○	▲	25	20	18	250	13	2	TW15P		FTGA03508	
E20R-SCLCR/L-09	▲	▲	25	20	18	200	13	2	TW15P		FTGA03508	
E20S-SCLCR/L-09	▲	▲	25	20	18	250	13	2	TW15P		FTGA03508	
C25T-SCLCR/L-12	○	●	32	25	23	300	17	2	CC_T1204_	TW15P	FTGA0411F	
E25T-SCLCR/L-12	▲	▲	32	25	23	300	17	2		TW15P	FTGA0411F	
C04G-SCLCR/L-03	▲	▲	5	4	3,8	90	2,5	1	CC_T0301_	TW06P	FTNA01633	
C05H-SCLCR/L-03	▲	▲	6	5	4,4	100	3	1		TW06P	FTNA01633	
C06H-SCLCR/L-04	▲	▲	7	6	5,4	100	3,5	1	CC_T0401_	TW06P	FTNA0238	
E06H-SCLCR/L-04	▲	▲	7	6	5,4	100	3,5	1		TW06P	FTNA0238	
C07K-SCLCR/L-04	▲	▲	8	7	6,4	125	4	1		TW06P	FTNA0238	
E07K-SCLCR/L-04	○	▲	8	7	6,4	125	4	1		TW06P	FTNA0238	



SCLPR/L

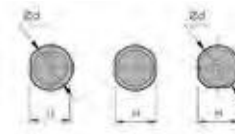
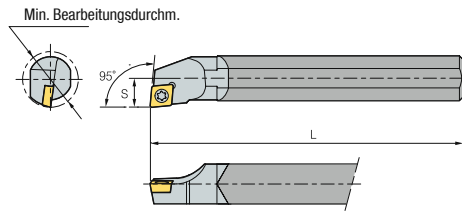
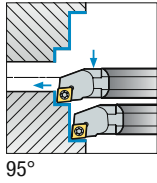

WSP



CP_

(mm)

Bezeichnung	L	R	ØD	Ød	H	L	S	Spannflächen	WSP	Schlüssel	Schraube
C10K-SCLPR/L-08	○	●	12	10	9	125	6	2	CP_T0802_	TW09P	FTNA0305
C10M-SCLPR/L-08	○	▲	12	10	9	150	6	2	CP_T0802_	TW09P	FTNA0305
E10K-SCLPR/L-08	○	●	12	10	9	125	6	2		TW09P	FTNA0305
E10M-SCLPR/L-08	○	●	12	10	9	150	6	2		TW09P	FTNA0305
C12M-SCLPR/L-08	○	●	15	12	11	150	7,5	2		TW09P	FTNA0306
C12M-SCLPR/L-09	○	●	15	12	11	150	8	2	CP_T0903_	TW15P	FTNA0408
C12Q-SCLPR/L-08	○	●	15	12	11	180	7,5	2	CP_T0802_	TW09P	FTNA0306
C12Q-SCLPR/L-09	○	●	15	12	11	180	8	2	CP_T0903_	TW15P	FTNA0408
E12M-SCLPR/L-08	○	●	15	12	11	150	7,5	2	CP_T0802_	TW09P	FTNA0306
E12M-SCLPR/L-09	○	●	15	12	11	150	8	2	CP_T0903_	TW15P	FTNA0408
E12Q-SCLPR/L-08	○	●	15	12	11	180	7,5	2	CP_T0802_	TW09P	FTNA0305
E12Q-SCLPR/L-09	○	●	15	12	11	180	8	2	CP_T0903_	TW15P	FTNA0408
C16R-SCLPR/L-09	○	●	20	16	15	200	10	2	CP_T0903_	TW15P	FTNA0408
C16S-SCLPR/L-09	▲	●	20	16	15	250	10	2		TW15P	FTNA0408
E16R-SCLPR/L-09	○	●	20	16	15	200	10	2		TW15P	FTNA0408
E16S-SCLPR/L-09	○	●	20	16	15	250	10	2		TW15P	FTNA0408
C20R-SCLPR/L-09	○	●	25	20	18	200	13	2		TW15P	FTNA0408
C20S-SCLPR/L-09	○	●	25	20	18	250	13	2		TW15P	FTNA0408
E20R-SCLPR/L-09	○	●	25	20	18	200	13	2		TW15P	FTNA0408
E20S-SCLPR/L-09	○	●	25	20	18	250	13	2		TW15P	FTNA0408



SDQCR/L

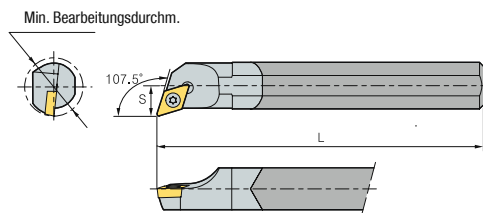
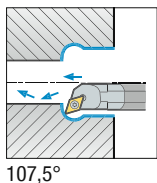

WSP



DC_

(mm)

Bezeichnung	L	R	ØD	Ød	H	L	S	Spannflächen	WSP	Schlüssel	Schraube
C08K-SDQCR/L-07	▲	▲	10	8	7	125	6	2	DC_T0702_	TW07P	FTKA02555
E08K-SDQCR/L-07	▲	▲	10	8	7	125	6	2		TW07P	FTKA02555
C10K-SDQCR/L-07	▲	▲	13	10	9	125	7	2		TW07P	FTKA02555
E10K-SDQCR/L-07	▲	▲	13	10	9	125	7	2		TW07P	FTKA02555
C12M-SDQCR/L-07	▲	▲	16	12	11	150	9	2		TW07P	FTKA02565
E12M-SDQCR/L-07	▲	▲	16	12	11	150	9	2		TW07P	FTKA02565
C16R-SDQCR/L-07	○	▲	20	16	15	200	11	2		TW07P	FTKA02565
C16R-SDQCR/L-11	▲	▲	20	16	15	200	11	2		DC_T11T3_	TW15P
E16R-SDQCR/L-07	▲	▲	20	16	15	200	11	2	DC_T0702_	TW07P	FTKA02565
E16R-SDQCR/L-11	▲	▲	20	16	15	200	11	2	DC_T11T3_	TW15P	FTGA03508
C20R-SDQCR/L-11	▲	▲	25	20	18	200	13	2	DC_T11T3_	TW15P	FTGA03508
C20S-SDQCR/L-11	○	▲	25	20	18	250	13	2		TW15P	FTGA03508
E20R-SDQCR/L-11	▲	▲	25	20	18	200	13	2		TW15P	FTGA03508
E20S-SDQCR/L-11	▲	▲	25	20	18	250	13	2		TW15P	FTGA03508



SDUCR/L

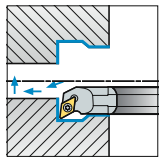

93°

Min. Bearbeitungsdurchm.

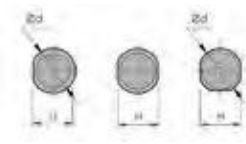
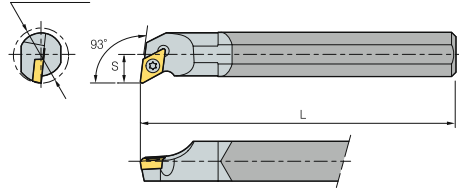

WSP



DC_

(mm)

Bezeichnung	L	R	ØD	Ød	H	L	S	Spannflächen	WSP	Schlüssel	Schraube
C10K-SDUCR/L-07	▲	▲	13	10	9	125	7	2	DC_T0702_	TW07P	FTKA02555
C10M-SDUCR/L-07	▲	▲	13	10	9	150	7	2		TW07P	FTKA02555
E10K-SDUCR/L-07	▲	▲	13	10	9	125	7	2		TW07P	FTKA02555
E10M-SDUCR/L-07	▲	▲	13	10	9	150	7	2		TW07P	FTKA02555
C12M-SDUCR/L-07	▲	▲	16	12	11	150	9	2		TW07P	FTKA02565
C12Q-SDUCR/L-07	▲	▲	16	12	11	180	9	2		TW07P	FTKA02565
E12M-SDUCR/L-07	▲	▲	16	12	11	150	9	2		TW07P	FTKA02565
E12Q-SDUCR/L-07	▲	▲	16	12	11	180	9	2		TW07P	FTKA02565
C16R-SDUCR/L-07	○	▲	20	16	15	200	11	2		TW07P	FTKA02565
C16R-SDUCR/L-11	○	▲	20	16	15	200	11	2	DC_T11T3_	TW15P	FTGA03508
C16S-SDUCR/L-07	○	▲	20	16	15	250	11	2	DC_T0702_	TW07P	FTKA02565
C16S-SDUCR/L-11	▲	▲	20	16	15	250	11	2	DC_T11T3_	TW15P	FTGA03508
E16R-SDUCR/L-07	▲	▲	20	16	15	200	11	2	DC_T0702_	TW07P	FTKA02565
E16R-SDUCR/L-11	▲	▲	20	16	15	200	11	2	DC_T11T3_	TW15P	FTGA03508
E16S-SDUCR/L-07	▲	▲	20	16	15	250	11	2	DC_T0702_	TW07P	FTKA02565
E16S-SDUCR/L-11	▲	▲	20	16	15	250	11	2	DC_T11T3_	TW15P	FTGA03508
C20R-SDUCR/L-11	▲	▲	25	20	18	200	13	2		TW15P	FTGA03508
C20S-SDUCR/L-11	▲	▲	25	20	18	250	13	2		TW15P	FTGA03508
E20R-SDUCR/L-11	▲	▲	25	20	18	200	13	2		TW15P	FTGA03508
E20S-SDUCR/L-11	▲	▲	25	20	18	250	13	2		TW15P	FTGA03508
C25T-SDUCR/L-11	▲	▲	32	25	23	300	17	2		TW15P	FTGA03510
E25T-SDUCR/L-11	▲	▲	32	25	23	300	17	2		TW15P	FTGA03510



STFCR/L

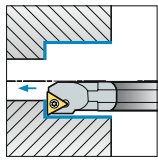

90°

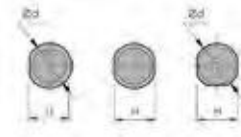
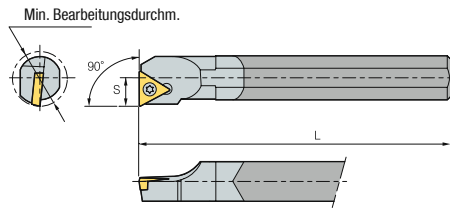

WSP



TC_

(mm)

Bezeichnung	L	R	ØD	Ød	H	L	S	Spannflächen	WSP	Schlüssel	Schraube
C08K-STFCR/L-09	○	▲	10	8	7	125	5	2	TC_T0902_	TW06P	FTKA02206
E08K-STFCR/L-09	▲	▲	10	8	7	125	5	2		TW06P	FTKA02206
C10K-STFCR/L-09	●	▲	12	10	9	125	6	2		TW06P	FTKA02206
C10K-STFCR/L-11	○	▲	12	10	9	125	6	2	TC_T1102_	TW07P	FTKA02565
E10K-STFCR/L-09	▲	▲	12	10	9	125	6	2	TC_T0902_	TW06P	FTKA02206
E10K-STFCR/L-11	▲	▲	12	10	9	125	6	2	TC_T1102_	TW07P	FTKA02565
C12M-STFCR/L-11	○	▲	15	12	11	150	8	2		TW07P	FTKA02565
E12M-STFCR/L-11	▲	▲	15	12	11	150	8	2		TW07P	FTKA02565
C16R-STFCR/L-11	▲	▲	20	16	15	200	10	2		TW07P	FTKA02565
E16R-STFCR/L-11	▲	▲	20	16	15	200	10	2		TW07P	FTKA02565
C20R-STFCR/L-11	○	●	25	20	18	200	13	2		TW07P	FTKA02565
C20R-STFCR/L-16	○	▲	25	20	18	200	13	2	TC_T16T3_	TW15P	FTGA03510
C20S-STFCR/L-11	○	●	25	20	18	250	13	2	TC_T1102_	TW07P	FTKA02565
C20S-STFCR/L-16	○	●	25	20	18	250	13	2	TC_T16T3_	TW15P	FTGA03510
E20R-STFCR/L-11	▲	▲	25	20	18	200	13	2	TC_T1102_	TW07P	FTKA02565
E20R-STFCR/L-16	○	▲	25	20	18	200	13	2	TC_T16T3_	TW15P	FTGA03510
E20S-STFCR/L-11	▲	▲	25	20	18	250	13	2	TC_T1102_	TW07P	FTKA02565
E20S-STFCR/L-16	▲	▲	25	20	18	250	13	2	TC_T16T3_	TW15P	FTGA03510



STFPR/L

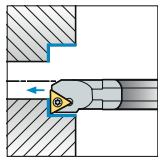

90°

Min. Bearbeitungsdurchm.

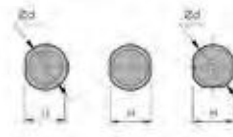
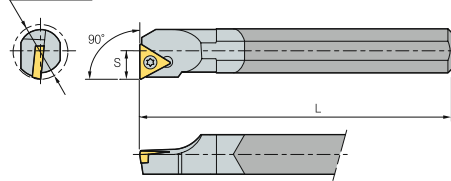

WSP



TP_

Bezeichnung	L	R	ØD	Ød	H	L	S	Spannflächen	WSP	Schlüssel	Schraube
C08K-STFPR/L-08	○	▲	10	8	7	125	5	2	TP_T0802_	TW06P	FTNA02205
E08K-STFPR/L-08	▲	●	10	8	7	125	5	2		TW06P	FTNA02205
C10K-STFPR/L-11	○	●	12	10	9	125	6	2	TP_T1103_	TW09P	FTNA0305
C10M-STFPR/L-11	○	●	12	10	9	150	6	2		TW09P	FTNA0305
E10K-STFPR/L-11	○	●	12	10	9	125	6	2		TW09P	FTNA0305
E10M-STFPR/L-11	○	▲	12	10	9	150	6	2		TW09P	FTNA0305
C12M-STFPR/L-11	▲	●	15	12	11	150	8	2		TW09P	FTNA0307
C12Q-STFPR/L-11	○	●	15	12	11	180	8	2		TW09P	FTNA0307
E12M-STFPR/L-11	○	●	15	12	11	150	8	2		TW09P	FTNA0307
E12Q-STFPR/L-11	○	▲	15	12	11	180	8	2		TW09P	FTNA0307
C16R-STFPR/L-11	○	●	20	16	15	200	10	2		TW09P	FTNA0307
C16S-STFPR/L-11	○	●	20	16	15	250	10	2		TW09P	FTNA0307
E16R-STFPR/L-11	○	▲	20	16	15	200	10	2		TW09P	FTNA0307
E16S-STFPR/L-11	○	●	20	16	15	250	10	2		TW09P	FTNA0307
C20R-STFPR/L-11	○	●	25	20	18	200	13	2		TW09P	FTNA0307
C20R-STFPR/L-16	○	●	25	20	18	200	13	2	TP_T1604_	TW15P	FTNA0408
C20S-STFPR/L-11	○	●	25	20	18	250	13	2	TP_T1103_	TW09P	FTNA0307
C20S-STFPR/L-16	○	●	25	20	18	250	13	2	TP_T1604_	TW15P	FTNA0408
E20R-STFPR/L-11	○	●	25	20	18	200	13	3	TP_T1103_	TW09P	FTNA0307
E20R-STFPR/L-16	○	●	25	20	18	200	13	2	TP_T1604_	TW15P	FTNA0408
E20S-STFPR/L-11	○	●	25	20	18	250	13	2	TP_T1103_	TW09P	FTNA0307
E20S-STFPR/L-16	○	●	25	20	18	250	13	2	TP_T1604_	TW15P	FTNA0408
C25T-STFPR/L-16	○	●	32	25	23	300	17	2		TW15P	FTNA0408
E25T-STFPR/L-16	○	●	32	25	23	300	17	2		TW15P	FTNA0408

(mm)

STUBR/L

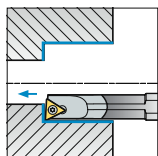

93°

Min. Bearbeitungsdurchm.

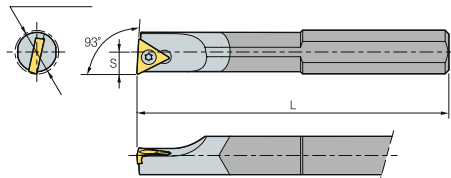

WSP



TB_

Bezeichnung	L	R	ØD	Ød	H	L	S	Spannflächen	WSP	Schlüssel	Schraube
C06H-STUBR/L-06	○	▲	8	6	5	100	4	1	TB_T0601_	TW06P	FTNA0204
C08K-STUBR/L-06	○	▲	10	8	7	125	5	2		TW06P	FTNA0204
E08K-STUBR/L-06	○	▲	10	8	7	125	5	2		TW06P	FTNA0204
C10K-STUBR/L-06	○	▲	12	10	9	125	6	2		TW06P	FTNA0204
E10K-STUBR/L-06	○	●	12	10	9	125	6	2		TW06P	FTNA0204

(mm)



STUPR/L

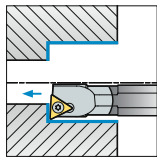

93°

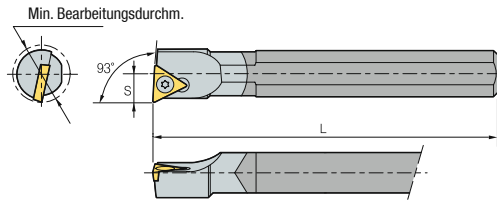

WSP



TP_

(mm)

Bezeichnung	L	R	ØD	Ød	H	L	S	Spannflächen	WSP	Schlüssel	Schraube
C08K-STUPR/L-08	○	▲	10	8	7	125	5	2	TP_T0802_	TW06P	FTNA02205
E08K-STUPR/L-08	○	▲	10	8	7	125	5	2		TW06P	FTNA02205
C10K-STUPR/L-11	○	●	12	10	9	125	6	2	TP_T1103_	TW09P	FTKA0305
C10M-STUPR/L-11	○	▲	12	10	9	150	6	2		TW09P	FTKA0305
E10K-STUPR/L-11	▲	▲	12	10	9	125	6	2		TW09P	FTKA0305
E10M-STUPR/L-11	○	●	12	10	9	150	6	2		TW09P	FTKA0305
C12M-STUPR/L-11	○	●	15	12	11	150	8	2		TW09P	FTNA0307
C12Q-STUPR/L-11	○	●	15	12	11	180	8	2		TW09P	FTNA0307
E12M-STUPR/L-11	○	●	15	12	11	150	8	2		TW09P	FTNA0307
E12Q-STUPR/L-11	○	●	15	12	11	180	8	2		TW09P	FTNA0307
C16R-STUPR/L-11	○	●	20	16	15	200	10	2		TW09P	FTNA0307
C16S-STUPR/L-11	▲	▲	20	16	15	250	10	2		TW09P	FTNA0307
E16R-STUPR/L-11	○	●	20	16	15	200	10	2		TW09P	FTNA0307
E16S-STUPR/L-11	○	●	20	16	15	250	10	2		TW09P	FTNA0307
C20R-STUPR/L-11	○	●	25	20	18	200	13	2		TW09P	FTNA0307
C20R-STUPR/L-16	○	●	25	20	18	200	13	2	TP_T1604_	TW15P	FTNA0408
C20S-STUPR/L-11	○	●	25	20	18	250	13	2	TP_T1103_	TW09P	FTNA0307
C20S-STUPR/L-16	○	●	25	20	18	250	13	2	TP_T1604_	TW15P	FTNA0408
E20R-STUPR/L-11	○	●	25	20	18	200	13	2	TP_T1103_	TW09P	FTNA0307
E20R-STUPR/L-16	○	●	25	20	18	200	13	2	TP_T1604_	TW15P	FTNA0408
E20S-STUPR/L-11	▲	●	25	20	18	250	13	2	TP_T1103_	TW09P	FTNA0307
E20S-STUPR/L-16	○	●	25	20	18	250	13	2	TP_T1604_	TW15P	FTNA0408
C25T-STUPR/L-16	○	●	32	25	23	300	17	2		TW15P	FTNA0408
E25T-STUPR/L-16	▲	●	32	25	23	300	17	2		TW15P	FTNA0408



SWUBR/L

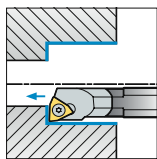

93°

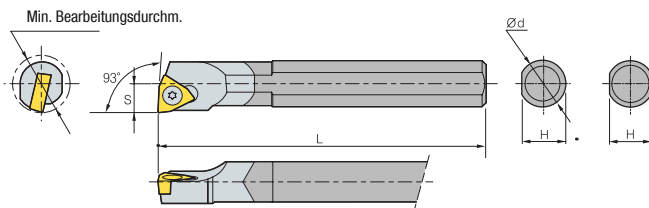

WSP



WB_T

(mm)

Bezeichnung	L	R	ØD	Ød	H	L	S	Spannflächen	WSP	Schlüssel	Schraube
C08K-SWUBR/L-S3	○	●	10	8	7	125	4,5	2	WB_TS302_	TW06P	FTNA02205
E08K-SWUBR/L-S3	○	●	10	8	7	125	5	2		TW06P	FTNA02205
C05H-SWUBR/L-02	○	▲	6	5	4,4	100	3	1	WB_T0201_	TW06P	FTNA0203
C06H-SWUBR/L-02	○	▲	7	6	5,4	100	3,5	1		TW06P	FTNA0203
E06H-SWUBR/L-02	○	▲	7	6	5,4	100	3,5	-		TW06P	FTNA0203
C08K-SWUBR/L-02	▲	▲	9	8	7	125	4,5	2		TW06P	FTNA02033
E08K-SWUBR/L-02	○	▲	9	8	7	125	4,5	2		TW06P	FTNA02033



KORLOY Bohrstangen-Set



Die neuen Bohrstangen im Set

Überzeugende Qualität für höchste Ansprüche, für Sie zusammengestellt:
Bohrstangen und passende Wendeschneidplatten.

Senden Sie Ihre Anfrage an vertrieb@korloyeurope.com
oder rufen Sie uns an.

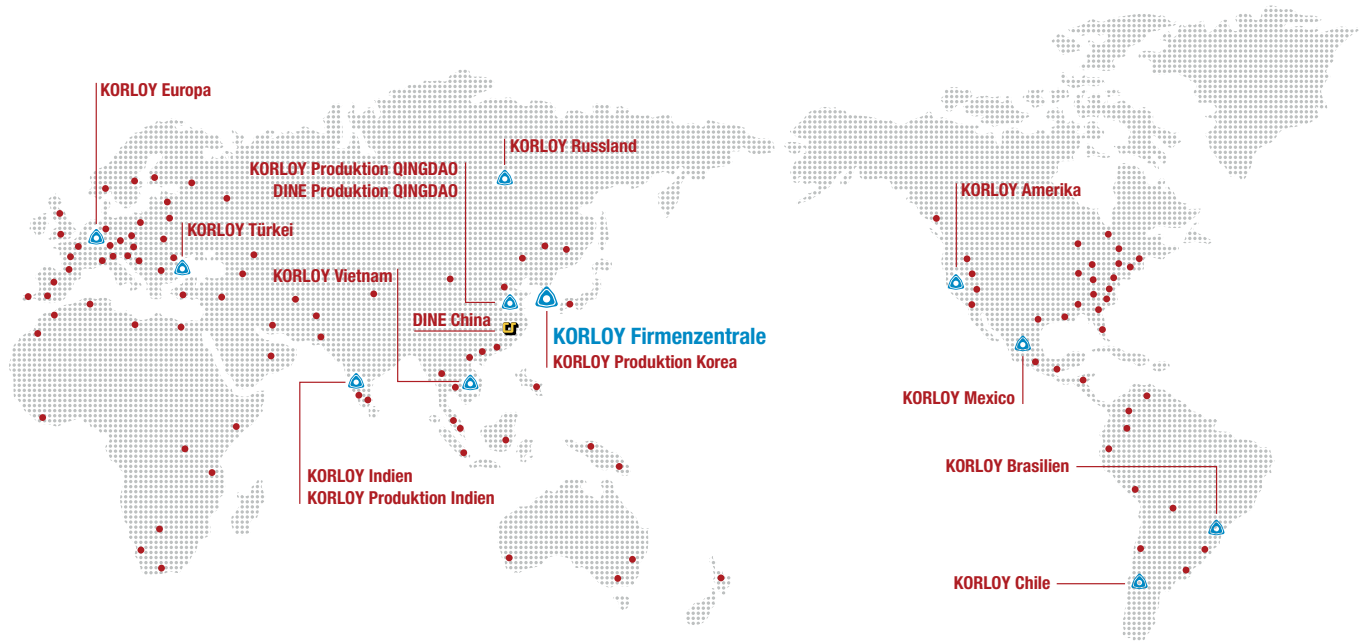

Firmenzentrale

Holystar B/D. 1350. Nambusunhwan-ro. Geumcheon-gu. Seoul. 08536. Korea Web: www.korloy.com

Forschung & Entwicklung Seoul

Holystar B/D. 1350. Nambusunhwan-ro. Geumcheon-gu. Seoul. 08536. Korea

Forschung, Entwicklung & Produktion Cheongju

55. Sandan-ro. Heungdeok-gu. Cheongju-si. Chungcheongbuk-do. 28589. Korea

Jincheon Produktion

54. Gwanghyewonsandan 2-gil. Gwanghyewon-myeon. Jincheon-gun. Chungcheongbuk-do. 27807. Korea

Qingdao Produktion China

Ground Dongjing Road 56(B) District Free Trade Zone. Qingdao, China

Gurgaon Produktion Indien

Plot No. 415. Sector 8. IMT Manesar. Gurgaon 122051. Haryana. Indien



620. Maple Avenue. Torrance. CA 90503. USA



Plot NO. 415, Sector 8, IMT Manesar, Gurgaon 12205. Haryana. Indien



Av. Aruana 280. conj.12. WLC. Alphaville. Barueri. CEP06460-010. SP. Brasilien



No. 133 Le Loi street. Hoa Phu ward. Thu Dau Mot city. Binh Duong proviende. Vietnam



Istanbul Ticaret Sarayı, Oruçreis Mahallesi, Vadi Cd. No:170, 34235 Esenler/Istanbul, Türkei



Av. Providencia 1650, Office 1009, 7500027, Providencia-Santiago, Chile



Gablonzler Straße 25-27. D-61440 Oberursel. Tel.: +49-6171-27783-0. Fax: +49-6171-27783-59
E-Mail: info@korloyeurope.com. Web: www.korloyeurope.com

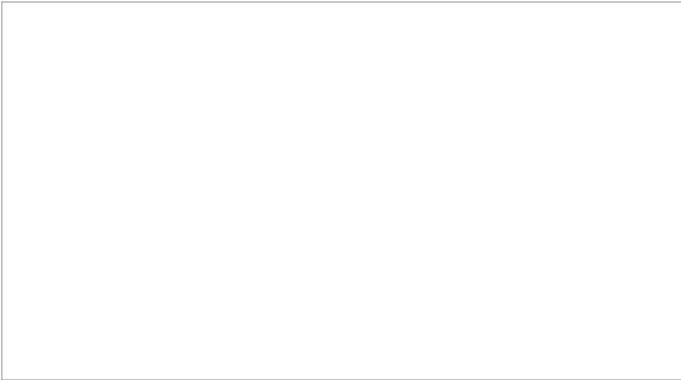

KTS - Korloy Tooling Solution



Gratis-APP im Store

Einfach kostenlos herunterladen, installieren und verwenden.



20190715

Turning-01-de