

Young
CUTTINGTOOLS

CHAMFER KING SERIES



Features Description

The indexable countersink with carbide insert can be used in all kinds of machines, include drilling machine, electric hand tool...etc. The patented unique design "carbide strip" enhance the cutter toollife. Available from $\varnothing 4$ - $\varnothing 110$ mm.



INDEXABLE CHAMFER KING

PATENTED



Video

Features

Available in
materials



Cost
300~500%
SAVING

Adapter
type is
available
max. 300mm

Applicable
Machines

Milling / drilling
/ lathe / electric
hand tool

Efficiency
300%
UP

Durability
500~1000%
UP

Product Design

CUTTING.
RANGE
ø4.0~ø110 mm

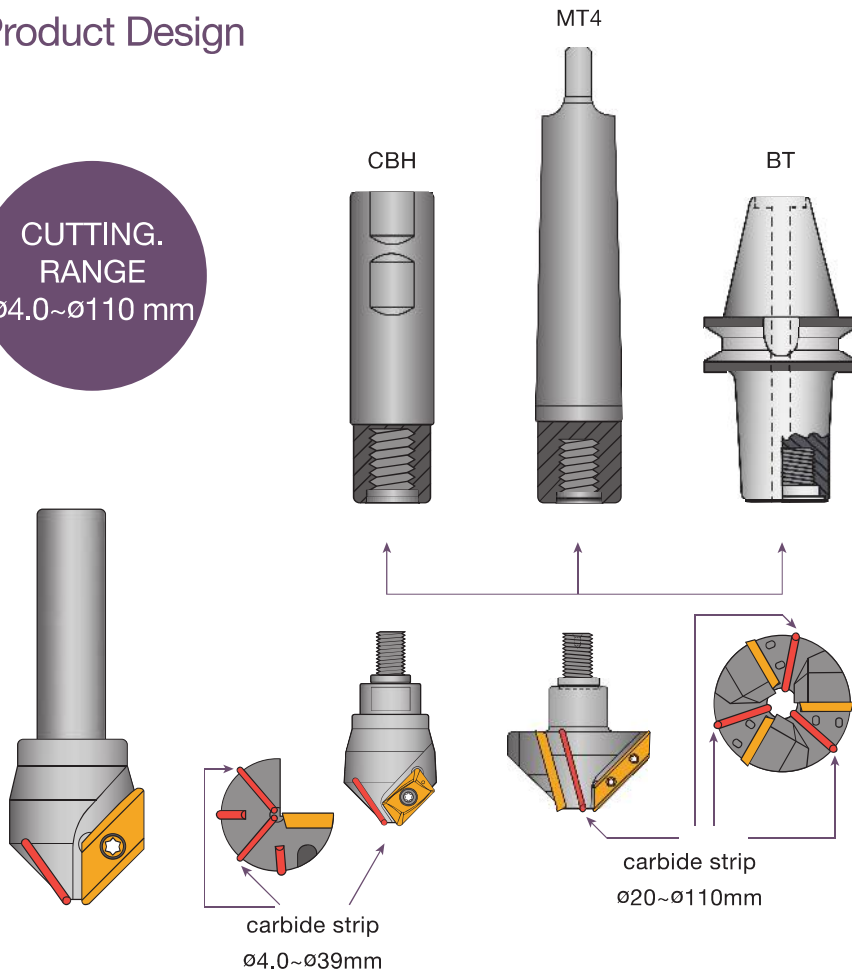

Carbide Strip Cutter With Carbide Inserts:

- Special design for unstable drilling machines and electric drills. It's working well even in lower RPM.
- Carbide strips support better tool life.
- The carbide insert performs a better tool life. It was designed with 2 cutting edges, one insert grade suitable for all materials, tend to be more economical.
- Patented carbide strip cutter design provides an excellent chamfering surface.

Chamfer

New coming shank

The shank with three flat designs is more suitable for drilling machine (three-jaw chuck) which achieves stable clamping and longer tool life.



▲ Optimal surface finishing

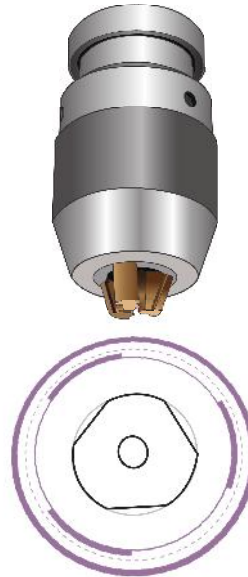

▲ Top view of the shank

Geometries Application

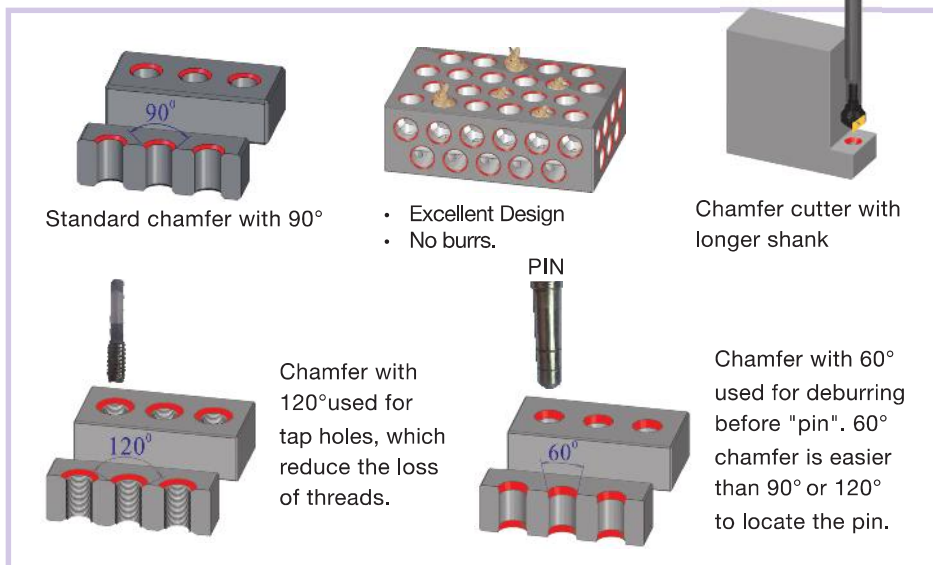

Applicable Machine And Tools

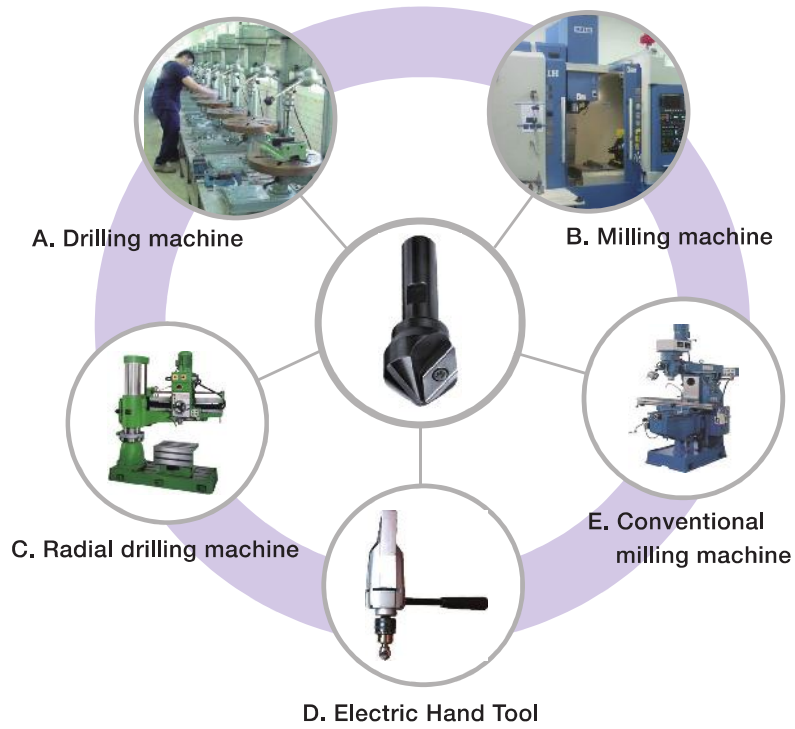

Cost Effective Solution

Coated carbide insert provides excellent tool life. Insert with 2 cutting edges maximizes tool cost-saving.

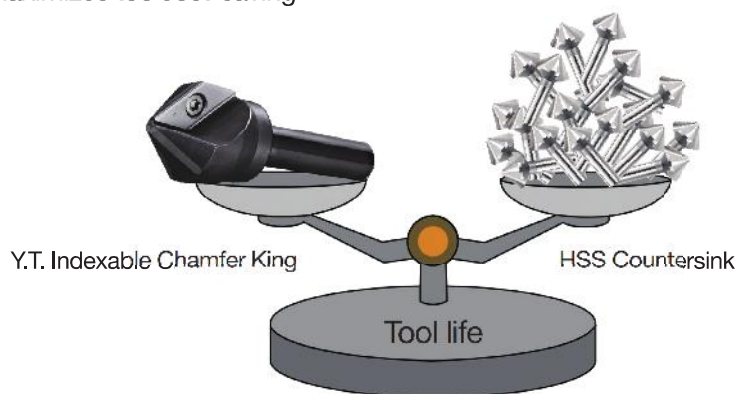

PRODUCT SPECIFICATIONS

Chamfer King Toolholders

- Inserts P. 257
- Cutting Data P. 258 - 259

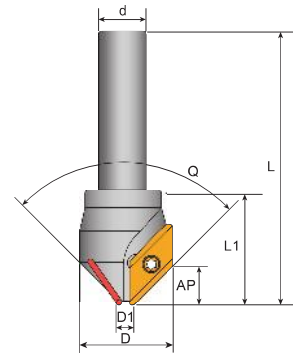

CI

- 60°

Order Code	Dimensions (mm)						Q	Z	KG	MAX RPM	Inserts XDGT	Screw	Key
	D1	D	d	L	AP	L1							
CI-17-60°	7	17	10	65	8.5	27	60°	1	0.12	35000	120308	C03506	T10P
CI-31-60°	15.5	31	12	78	13	35			0.24	25000	190408	C04011	T15P

- 90°

Order Code	Dimensions (mm)						Q	Z	KG	MAX RPM	Inserts ADGT/XDGT	Screw	Key	
	D1	D	d	L	AP	L1								
CI-12-90°	4	10	10	60	3	14	90°	1	0.08	45000	060204	C018035	T06P	
CI-12-90° -L				90					0.10					
CI-22-90°	5.5	22	65	8	27	0.14			35000	120308	C03506	T10P		
CI-36-90°	15	36	12	78	10	38			2	0.32	25000	190408	C04011	T15P
CI-36-90° -2										0.33				

- 100°

Order Code	Dimensions (mm)						Q	Z	KG	MAX RPM	Inserts ADGT/XDGT	Screw	Key	
	D1	D	d	L	AP	L1								
CI-12-100°	4	10	10	60	3	14	100°	1	0.05	45000	060204	C018035	T06P	
CI-24-100°	5	24		65	7.5	27			0.15	35000	120308	C03506	T10P	
CI-38-100°	15	38	12	78	10	38			2	0.40	25000	190408	C04011	T15P
CI-38-100° -2										0.41				

- 120°

Order Code	Dimensions (mm)						Q	Z	KG	MAX RPM	Inserts XDGT	Screw	Key
	D1	D	d	L	AP	L1							
CI-26-120°	7	26	10	65	5	27	120°	1	0.18	35000	120308	C03506	T10P
CI-39-120°	11	39	12	78	8	35			0.36	25000	190408	C04011	T15P

- Insert is included with purchase of a chamfer king.

Chamfer King Toolholders

- Combi holders P. 255 - 256
- Inserts P. 257
- Cutting Data P. 258 - 259

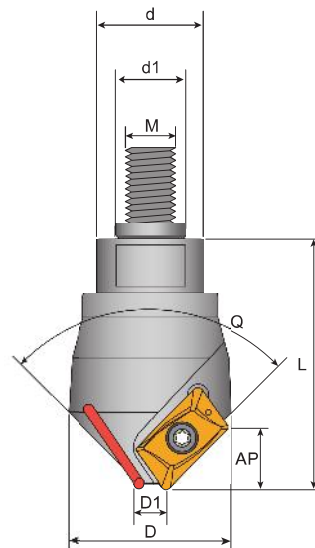

HCI

- 60°

Order Code	Dimensions (mm)							Q	Z	KG	MAX RPM	Inserts xDGT	Screw	Key
	D1	D	d	d1	L	AP	M							
HCI-17-60°	7	17	12	6.5	37	8.5	6	60°	1	0.12	35000	120308	C03506	T10P
HCI-31-60°	15.5	31	16	8.5	45	13	8			0.24	25000	190408	C04011	T15P

- 90°

Order Code	Dimensions(mm)							Q	Z	KG	MAX RPM	Inserts ADGT/XDGT	Screw	Key
	D1	D	d	d1	L	AP	M							
HCI-12-90°	4	10	10	6.5	24	3	6	90°	1	0.08	45000	060204	C018035	T06P
HCI-22-90°	5.5	22	12		37	8				0.14	35000	120308	C03506	T10P
HCI-36-90°	15	36	16	8.5	48	10	8			0.32	25000	190408	C04011	T15P

Chamfer

- 120°

Order Code	Dimensions(mm)							Q	Z	KG	MAX RPM	Inserts xDGT	Screw	Key
	D1	D	d	d1	L	AP	M							
HCI-26-120°	7	26	12	6.5	37	5	6	120°	1	0.18	35000	120308	C03506	T10P
HCI-39-120°	11	39	16	8.5	45	8	8			0.36	25000	190408	C04011	T15P

- Insert is included with purchase of a chamfer king.

Chamfer King Toolholders

- Combi holders P. 255 - 256
- Insert P. 257
- Cutting Data P. 258 - 259

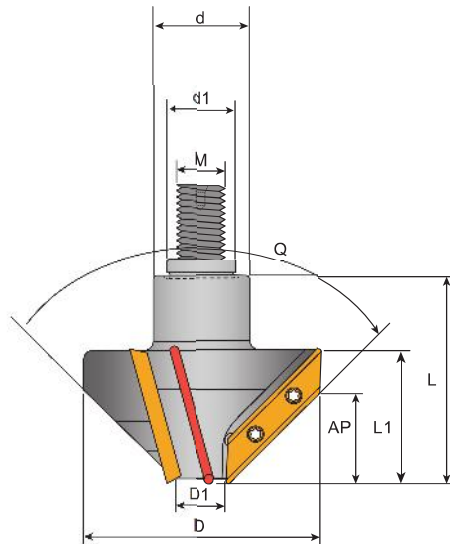

HCI

- 90°

Order Code	Dimensions (mm)									Z	kg	MAX RPM	Inserts XDGT	Screw	Key
	D1	D	d	d1	L	AP	L1	M	Q						
HCI-76-90°	20	76	30	22	65	28	41	16	90°	3	0.85	13700	400408	C04011	T15P
HCI-110-90°	55	110													

Note:

- For clunker radial drilling machine which is too stiff to position at the hole center of workpiece it might cause vibration and poor surface finishing during machining.

- For workpieces which are heavy and difficult to align the toolcenter, it might cause vibration and results in chatter marks on the chamfering surface.



BT Arbor (Screw Type)

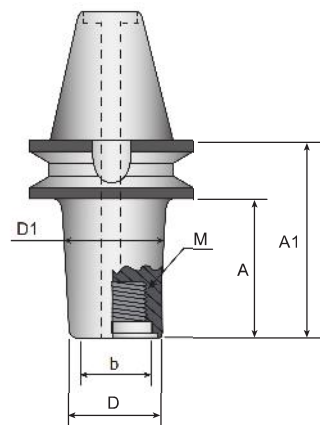

BT

Order Code	Dimensions (mm)						KG
	D	A	A1	b	D1	M	
BT40-2380A	23	53	78	14	28	M12	1.40
BT40-23120A		93	118		31		2.00
BT40-3080A	30	53	78	22	35	M16	2.40
BT40-30120A		93	118		38		2.90
BT40-4080A	40	53	78	28	45	M18	4.60
BT40-40120A		93	118		48		4.80
BT50-2380A	23	42	77	14	28	M12	4.60
BT50-23120A		82	117		31		5.50
BT50-3080A	30	42	77	22	35	M16	5.30
BT50-30120A		82	117		38		6.30
BT50-4080A	40	42	77	28	45	M18	6.10
BT50-40120A		82	117		48		7.00
BT50-5080A	50	42	77	36	55	M25	8.10
BT50-50120A		82	117		58		
BT50-50160A		122	157		61		

Chamfer

Chamfer King Combi Toolholders

CBH

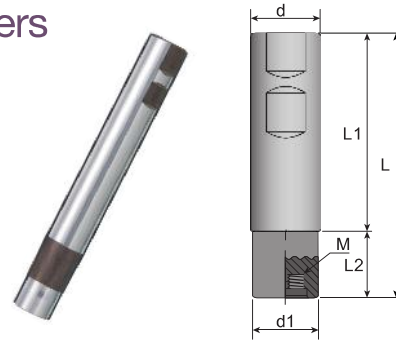

Order Code	Dimensions (mm)						
	d	d1	L1	L2	L	M	KG
CBH-1009-100	10	9	60	20	80	M6	0.05
CBH-1211-120	12	11	80		100		0.09
CBH-1211-140			100		120		0.11
CBH-1616-100	16	16	-	-	70	M8	0.11
CBH-1615-120		15	70	20	90		0.14
CBH-1615-150			95	25	120		0.18
CBH-3232-120	32	32	-	-	80	M16	0.48
CBH-3230-140		30	80	20	100		0.56
CBH-3230-200			130	30	160		0.92
CBH-3230-240			170		200		1.16
CBH-3230-300		210	50	260	1.53		

MTH

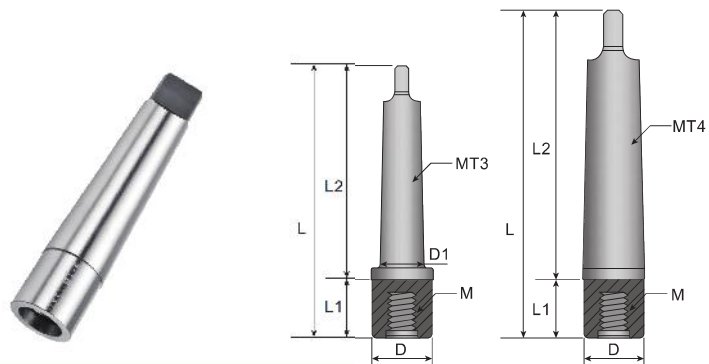





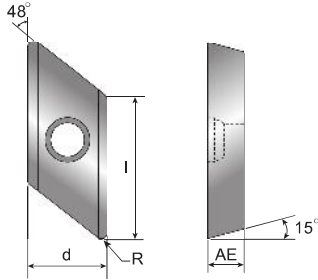

Order Code	Dimensions (mm)							
	D	D1	L	L1	L2	M	MT	KG
MTH-3	30	23.83	140	40	100	M16	3	0.50
MTH-4	31.6	-	165		125	M16	4	0.60

XDGT Chamfer King Insert



	Tolerances (mm)		
	d	AE	I
XDGT12	±0.03	±0.025	±0.03
XDGT19	±0.03	±0.025	±0.03
XDGT40	±0.03	±0.025	±0.03

Code	Dimensions (mm)				
	l	d	AE	Q	Q1
120308	12	8.3	3.10	0.8	-
190408	19	10.45	4.45	0.8	-
400408	40	10.45	4.70	0.8	-

Inserts	Order Code	Grades											
		Coated					Cermets			Uncoated			
		B100	C200	C250	F20	F30	CE25	CE100	CE60	K10	CE		
	XDGT120308TR-ME-C	★											
	XDGT190408TR-ME	★											Inserts 10 PCS / Box
	XDGT400408TR-ME	★											 Inserts 2 PCS / Box

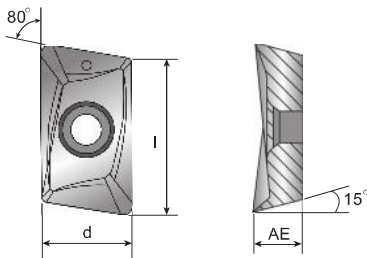

★ All Materials

ADGT Chamfer King Insert



	Tolerances (mm)	
	d	AE
ADGT	±0.03	±0.025

Code	Dimensions (mm)		
	d	l	AE
060204	4.15	6.5	2.6

Inserts	Order Code	Grades											
		Coated					Cermets			Uncoated			
		B100	C200	C250	F20	F30	CE25	CE100	CE60	K10	CE		
	ADGT060204TR-ME-C	★											
													Inserts 10 PCS / Box

★ All Materials

Chamfer

TECHNICAL GUIDE

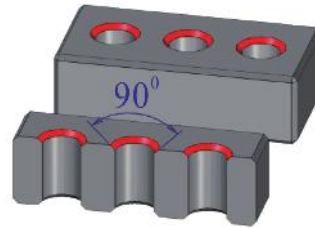

- Cutting data for hole countersinking

Material group												
Dia. of Hole (φmm)	Steel	Harden steel	Stainless steel	Cast iron			Aluminum			Titanium alloy Ni based superalloy Co-based superalloys		
	1 2 3 4 5 6	7	8 9 10 11	12 13 14 15			16 17 18			19 20 21 22		
	Vc: 20 m/min Fz: 0.1 mm/tooth			Vc: 15 m/min Fz: 0.12 mm/tooth			Vc: 50 m/min Fz: 0.15 mm/tooth			Vc: 20 m/min Fz: 0.1 mm/tooth		
	RPM rev/min	Feed mm/min 1 Tooth 3 Teeth		RPM rev/min	Feed mm/min 1 Tooth 3 Teeth		RPM rev/min	Feed mm/min 1 Tooth 3 Teeth		RPM rev/min	Feed mm/min 1 Tooth 3 Teeth	
5~7	1062	106	-	796	96	-	2654	398	-	796	80	-
8~10	708	71	-	531	64	-	1769	265	-	531	53	-
11~13	531	53	-	398	48	-	1327	199	-	398	40	-
14~16	425	42	-	318	38	-	1062	159	-	318	32	-
17~19	354	35	-	265	32	-	885	133	-	265	27	-
20~22	303	30	91	227	27	82	758	114	341	227	23	68
23~25	265	27	80	199	24	72	663	100	299	199	20	60
26~28	236	24	71	177	21	64	590	88	265	177	18	53
29~31	212	21	64	159	19	57	531	80	239	159	16	48
32~34	193	19	58	145	17	52	483	72	217	145	14	43
35~37	177	18	53	133	16	48	442	66	199	133	13	40
38~40	163	16	49	122	15	44	408	61	184	122	12	37
41~43	152	-	45	114	-	41	379	-	171	114	-	34
44~46	142	-	42	106	-	38	354	-	159	106	-	32
47~49	133	-	40	100	-	36	332	-	149	100	-	30
50~52	125	-	37	94	-	34	312	-	141	94	-	28
53~55	118	-	35	88	-	32	295	-	133	88	-	27
56~58	112	-	34	84	-	30	279	-	126	84	-	25

Technical Guide

Material group																						
Dia. of Hole (ϕ mm)	Steel		Harden steel	Stainless steel		Cast iron			Aluminum			Titanium alloy Ni based superalloy Co-based superalloys										
	1	2	3	4	5	6	7	8	9	10	11	12	13	14	15	16	17	18	19	20	21	22
	Vc: 20 m/min Fz: 0.1 mm/tooth						Vc: 15m/min Fz: 0.12mm/tooth			Vc: 50m/min Fz: 0.15mm/tooth			Vc: 20m/min Fz: 0.1mm/tooth									
	RPM rev/min		Feed mm/min		RPM rev/min		Feed mm/min		RPM rev/min		Feed mm/min		RPM rev/min		Feed mm/min							
			1 Tooth	3 Teeth	rev/min	1Tooth	3Teeth	rev/min	1Tooth	3Teeth	rev/min	1Tooth	3Teeth	rev/min	1Tooth	3Teeth						
59~61	106	-	-	32	80	-	29	265	-	119	80	-	24									
62~64	101	-	-	30	76	-	27	253	-	114	76	-	23									
65~67	97	-	-	29	72	-	26	241	-	109	72	-	22									
68~70	92	-	-	28	69	-	25	231	-	104	69	-	21									
71~73	88	-	-	27	66	-	24	221	-	100	66	-	20									
74~76	85	-	-	25	64	-	23	212	-	96	64	-	19									
77~79	82	-	-	24	61	-	-	204	-	92	61	-	18									
80~82	79	-	-	24	59	-	-	197	-	88	59	-	18									
83~85	76	-	-	23	57	-	-	190	-	85	57	-	17									
86~88	73	-	-	22	55	-	-	183	-	82	55	-	16									
89~91	71	-	-	21	53	-	-	177	-	80	53	-	16									
92~94	68	-	-	21	51	-	-	171	-	77	51	-	15									
95~97	66	-	-	20	50	-	-	166	-	75	50	-	15									
98~100	64	-	-	19	48	-	-	161	-	72	48	-	14									
101~103	62	-	-	19	47	-	-	156	-	70	47	-	14									
104~106	61	-	-	18	45	-	-	152	-	68	45	-	14									
107~109	59	-	-	18	44	-	-	147	-	66	44	-	13									
110	58	-	-	17	43	-	-	145	-	65	43	-	13									

Chamfer

CHAMFER MILLING CUTTERS SERIES



Features



Available in
materials

P K M
N S H



Cost
100~300%
SAVING



Applicable
Machines
CNC Milling machine



Efficiency
300%
UP



Durability
300%
UP

Product Application

Type of operation

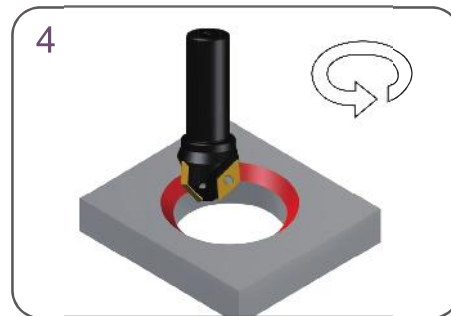
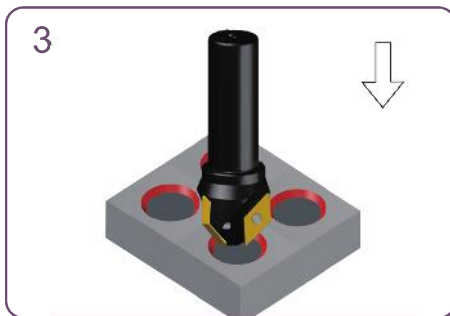
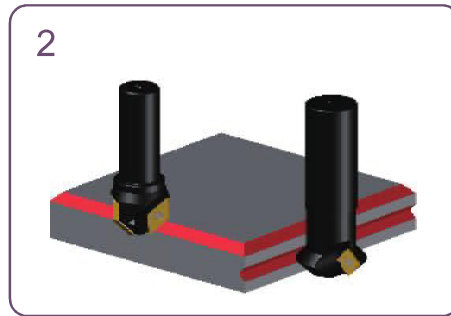
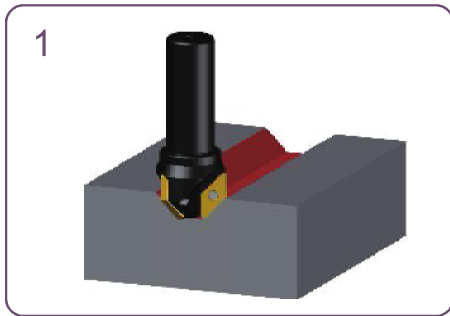

Chamfer

Chamfer Milling Cutters

- Inserts P. 275
- Cutting Data P. 258 - 259

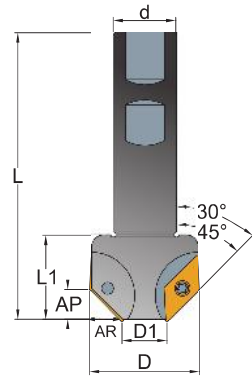

C

Order Code	Dimensions (mm)							Z	KG	MAX RPM	Inserts XDGT	Screw	Key
	D	D1	d	L	L1	AP	AR						
C-1124-30°	24	10	20	80	30	10	5	2	0.23	35000	120308	C03506	T10P
C-1633-30°	33	16	25	95	35	14	7.5		0.42	25000	190408	C04011	T15P
C-2260-30°	60	22	32	120	55	33	18.5	3	0.88	8500	400408		
C-1128-45°	28	10	20	80	30	8	8	2	0.28	35000	120308	C03506	T10P
C-1740-45°	40	17	25	95	35	11	11		3	0.48	25000	190408	C04011
C-1770-45°	70	17	32	110	50	28	28	0.96		8500	400408		

Product Applications

Type of operation

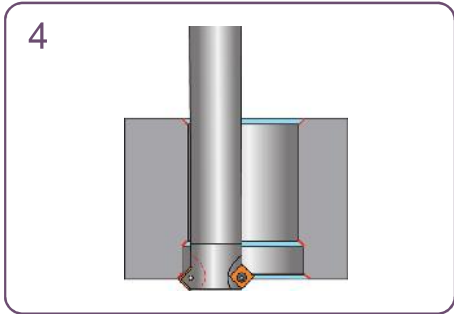
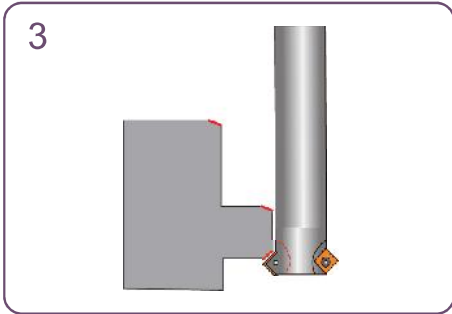
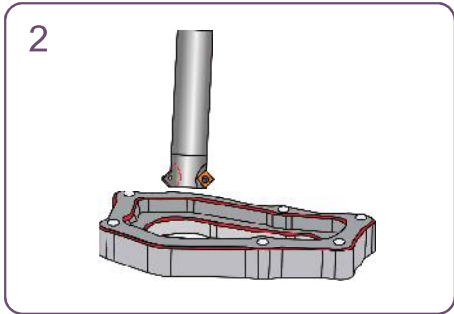
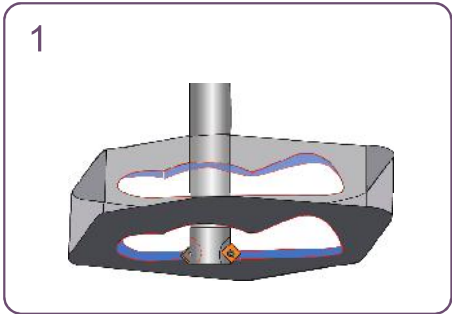

Chamfer

Dual Chamfer Milling Cutters

- Inserts P. 265
- Cutting Data P. 265
- Combi Toolholders P. 284 - 286



Order Code	Dimensions (mm)						Z	MAX RPM	Inserts SDET	Screw	Key
	D	D1	d	L	AP	M					
MC-1218	18	11	12	90	3	-	2	0.12	060208	C025045	T08P
MC-1625	25	19	16	100		-	3	0.21			
MC-2032	32	22	20	100	6	-	2	0.31	09T308	C04011	T15P
HMC-18	18	11	11	20	3	6	2	0.06	060208	C025045	T08P
HMC-25	25	19	15	30		8	3	0.09			
HMC-32	32	22	19	30	6	10	2	0.17	09T308	C04011	T15P

Inserts - SDET

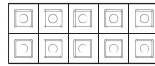
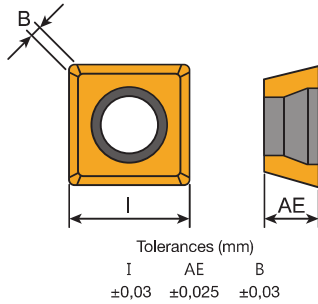

Inserts 10 PCS / Box

Code	Dimensions (mm)		
	I	AE	B
060208	6.0	2.3	0.4
09T308	9.0	3.97	0.5

Inserts	Order Code	Grades											
		Carbide					Metal cermet			Uncoated			
		B100	C200	C250	F20	F30	CE25	CE60		K10	CE		
	SDET060208N-ME	⊙											
	SDET09T308TN-M	⊙											
	SDET09T308TN-ME	⊙											

- Steel Stainless Steel Steel/Stainless Steel/Super alloy Cast Iron Aluminum Steel/Cast Iron
- Steel/Stainless Steel/Cast Iron
- Prices and stocks are based on present conditions
- Please specify model numbers and the grade of inserts, i.e.: SDET060208N-ME,B100

Recommended Cutting Data Insert Grades

Material Group	Recom. fz (mm/tooth)	Cutting Speed Vc (m/min)	Grades		
			SDET... M	SDET...ME	
1	0.08-0.20		-	B100	-
2	0.08-0.18	130 160 185	-	B100	-
3	0.08-0.18		-	B100	-
4	0.08-0.15		-	B100	-
5	0.06-0.13	120 140 160	-	B100	-
6	0.06-0.12	100 120 140	-	B100	-
7	0.08-0.18		B100	B100	-
8	0.08-0.15	65 80 90	-	B100	-
9	0.07-0.13		-	B100	-
10	0.06-0.12		-	B100	-
11	0.10-0.22	60 70 80	-	B100	-
12	0.10-0.22		-	F30	-
13	0.10-0.15		-	F30	-
14	0.10-0.15	100 120 140	-	F30	-
15	0.05-0.20		-	F30	-
16	0.05-0.20		-	-	-
17	0.06-0.10	400 500 600	-	-	-
18	0.06-0.15		-	-	-
19	0.05-0.08		-	B100	-
20	0.05-0.08		-	B100	-
21	0.06-0.10	30 40 50	-	B100	-
22	0.05-0.06		-	B100	-

Chamfer

CORNER ROUNDING CUTTER-390 SYSTEM



PATENTED

Patent No.
M473882
M474588
M473881

Patent No.
201310453057.2
201320772697.5

 PCT Priority



Video

Features

Available in
materials



Cost
300~500%
SAVING

Applicable
Machines
Milling

Efficiency
300%
UP

Durability
300%
UP

Product Design

390 SYSTEM

- Max.eccentricity: $\pm 0.008\text{mm}$
Accurate center positioning achieves excellent radius surface.
- 2 effective teeth.
- One shank fits max. 10 different inserts.
- The shank in $\varnothing 25\text{mm}$ are applicable with big radius inserts R6, R7, R8, R9, R10, that achieves marvellous productivity.

Insert radius: R1~R3

15-1616-100-R1~3



15-1616-130-R1~3

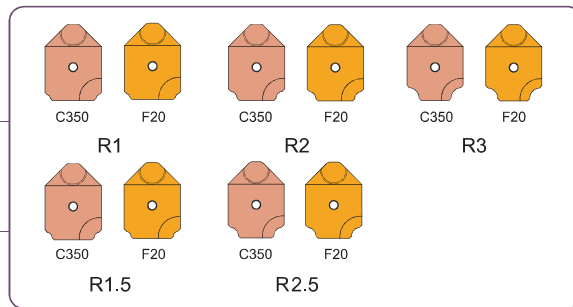

Insert radius: R4~R5

15-1616-100-R4~5



15-1616-130-R4~5

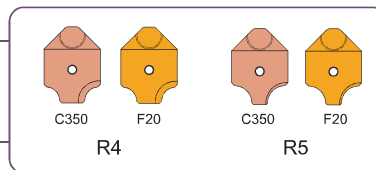

Insert radius: R6~R8

15-2525-100-R6~8



15-2525-130-R6~8

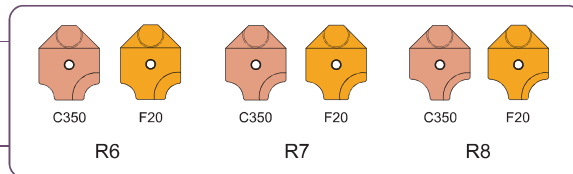

Insert radius: R9~R10

15-2525-100-R9~10



15-2525-130-R9~10

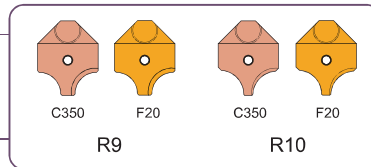

Chamfer

Indexable Corner Rounding Toolholders

- Inserts P. 269
- Cutting Data P. 271

15

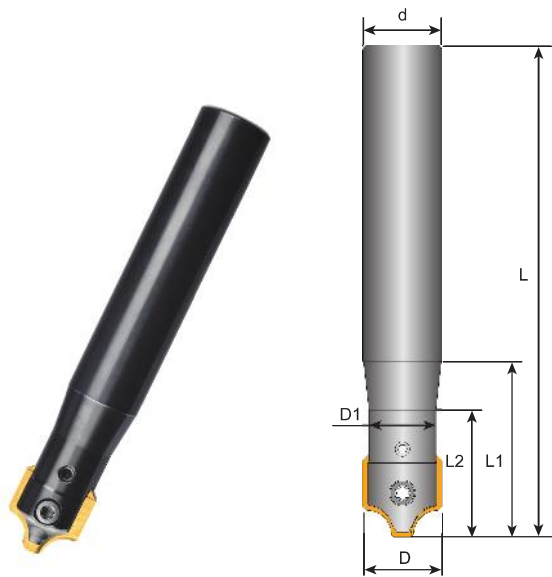

Order Code	Dimensions (mm)						KG	Inserts	Screw	Key
	D	D1	d	L	L1	L2				
15-1616-100-R1-3	16	14	16	100	35	25	0.21	R1-3	C03511 S0404	T10P L02
15-1616-130-R1-3				130			0.27			
15-1616-100-R4-5				100			0.21	R4-5		
15-1616-130-R4-5				130			0.27			
15-2525-110-R6-8	25	22	25	110	40	30	0.44	R6-8	C04017 S0508	T15P L025
15-2525-140-R6-8				140			0.58			
15-2525-110-R9-10				110			0.44	R9-10		
15-2525-140-R9-10				140			0.58			

268

25 Carbide Inserts



Inserts 6 PCS / Box
Only for insert :25-25***



Inserts 10 PCS / Box

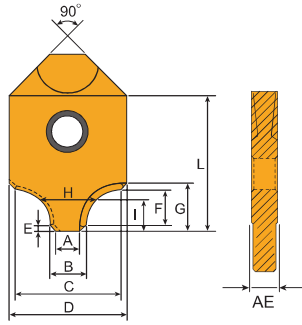

Tolerances (mm)
D : ± 0.05 AE : $\begin{matrix} +0.01 \\ -0.02 \end{matrix}$

Dimensions (mm)											
R	A	B	C	D	E	F	G	H	I	L	AE
1.0	12.0	13.29	15.17	16.30	0.64	0.96	2.33	13.86	1.30	21.5	3.0
1.5	11.0	12.29	15.16		0.67	1.47	2.85	13.15	1.69		
2.0	10.0	11.30	15.15		0.68	1.97	3.36	12.27	2.09		
2.5	9.00	10.31			0.67	2.47	3.85	11.74	2.39		
3.0	7.94	9.28	15.14		0.64	3.01	4.39	10.98	2.74		
4.0	6.00	7.29	15.09		0.67	3.97	5.37	9.58	3.45		
5.0	4.92	5.14	15.04	0.66	4.99	6.36	8.04	4.17			
6.0	11.2	12.38	24.15	25.15	0.58	5.96	7.16	15.84	4.76	30.0	3.5
7.0	9.20	10.30	24.08		0.55	6.96	8.14	14.35	5.44		
8.0	7.06	8.20	24.32		0.54	7.97	9.13	12.95	6.20		
9.0	4.80	5.93	23.98		0.56	9.00	10.18	11.22	6.93		
10.0	3.00	3.78	23.96		0.59	10.0	11.23	9.70	7.69		

Inserts	Order Code	Grades									
		Carbide					Cermet			Uncoated	
		C125	C200	C350	F20	F30	CE25	CE100	CE60	K10	CE
	25-1603-R1.0-E										
	25-1603-R1.5-E										
	25-1603-R2.0-E										
	25-1603-R2.5-E										
	25-1603-R3.0-E										
	25-1603-R4.0-E										
	25-1603-R5.0-E										
	25-2503-R6.0-E										
	25-2503-R7.0-E										
	25-2503-R8.0-E										
	25-2503-R9.0-E										
	25-2503-R10-E										
	25-1603-R1.0-ME										
	25-1603-R1.5-ME										
	25-1603-R2.0-ME										
	25-1603-R2.5-ME										
	25-1603-R3.0-ME										
	25-1603-R4.0-ME										
	25-1603-R5.0-ME										
	25-2503-R6.0-ME										
	25-2503-R7.0-ME										
	25-2503-R8.0-ME										
	25-2503-R9.0-ME										
	25-2503-R10-ME										

- Steel Stainless Steel Steel/Stainless Steel/Super alloy Cast Iron Aluminum Steel/Cast Iron
- Steel/Stainless Steel/Cast Iron
- Prices and stocks are based on present conditions
- Please specify model numbers the and grade of inserts, ie.: 25-1603-R1.0-E,F20

Chamfer

How to Fit Insert - Screw A.B.C.

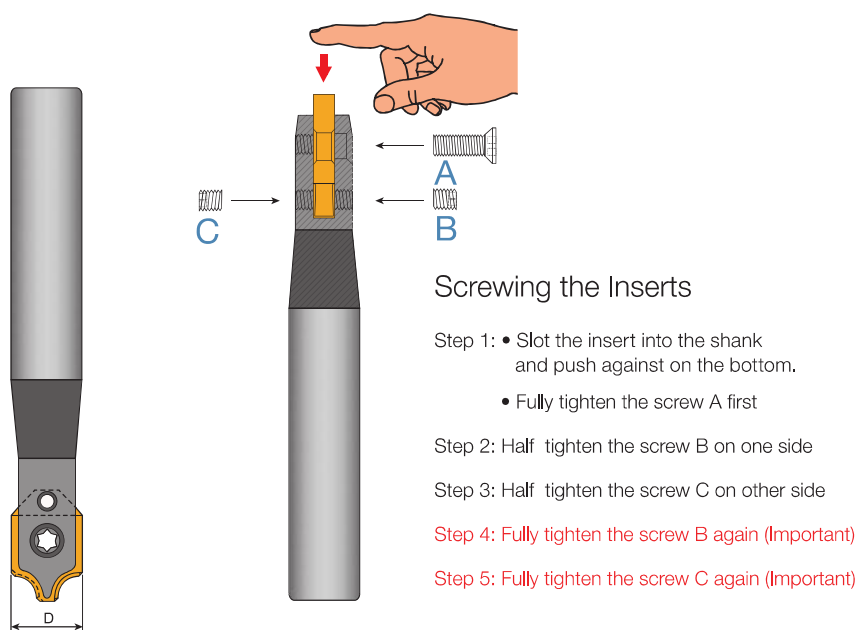

Standard spare parts

Insert dimension D (mm)	Screw A	Screw B/C	Key	Key
				
16	C03510	S0404	T10P	L02
25	C04017	S0508	T15P	L025

Recommended Cutting Data And Insert Grades

Material group	Recom. fz (mm/tooth) AR/Dc = 10%	Grades	
		ME	E
1	0.10-0.12	C350	-
2	0.10-0.12	C350	-
3	0.08-0.12	C350	-
4	0.07-0.10	C350	-
5	0.07-0.10	C350	-
6	0.06-0.08	C350	-
7	0.05-0.06	C350	-
8	0.10-0.12	C350	-
9	0.10-0.12	C350	-
10	0.08-0.10	C350	-
11	0.08-0.10	C350	-
12	0.12-0.15	C350	-
13	0.12-0.15	C350	-
14	0.10-0.12	C350	-
15	0.10-0.12	C350	-
16	0.08-0.10	-	F20
17	0.08-0.10	-	F20
18	0.08-0.10	-	F20

- Recommended cutting speed, Vc (m/min), Fz (mm/ tooth) in CHAMFERING process. The effective no. of teeth is calculated with 2 flutes.

Material group	Grades						
	C250	C350			CE60	F20	
		0.07	0.10	0.14			
1	-	207	186	167	-	-	-
2	-	186	167	150	-	-	-
3	-	167	150	135	-	-	-
4	-	150	135	120	-	-	-
5	-	135	120	109	-	-	-
6	-	120	108	97	-	-	-
7	-	48	43	-	-	-	-
8	-	160	-	80	-	-	-
9	-	160	-	80	-	-	-
10	-	80	-	50	-	-	-
11	-	80	-	50	-	-	-
12	-	170	145	125	-	-	-
13	-	155	125	115	-	-	-
14	-	110	90	82	-	-	-
15	-	110	90	-	-	-	-
16	-	-	-	-	1080	900	780
17	-	-	-	-	950	900	770
18	-	-	-	-	950	900	770

Chamfer