

WERKZEUGAUFNAHMEN

TOOLHOLDERS

PORTE-OUTILS

DIN ISO 10889

DIN 69880 (VDI 3425)

HAAS BMT 65

DIN ISO 10889

HAAS BMT 65

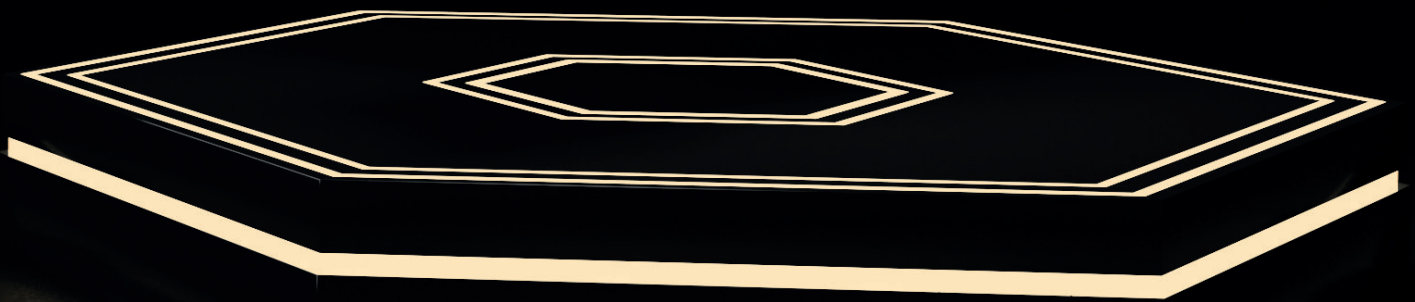
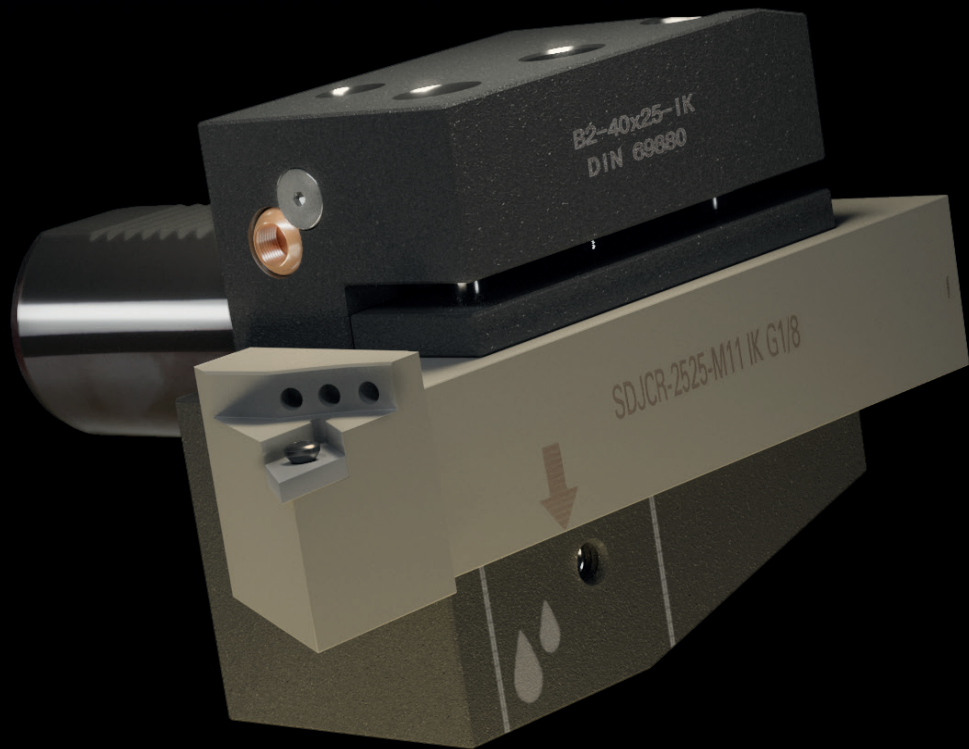

Toolholders DIN ISO 10889 (formerly DIN 69880 / VDI 3425)
 Porte-outils DIN ISO 10889 (l'ancien DIN 69880 / VDI 3425)

(DIN 69880)

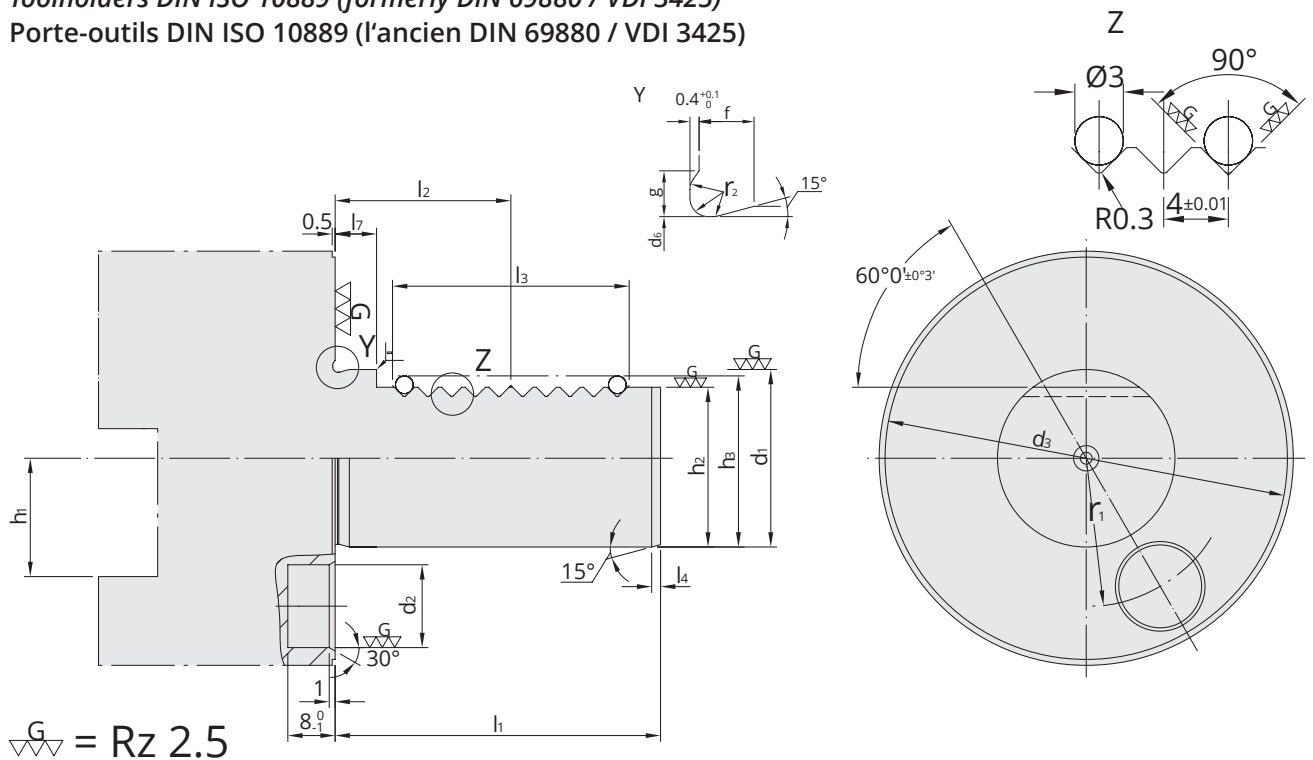

d_1 h_6	b	h_1 max.	d_2	d_3	h_2 $\pm 0,1$	r $\pm 0,02$	l_1 max.	l_2 $\pm 0,05$	l_3 max.	l_4 max.	l_5
16	42	12	8	40	15,0	14,5	32	12,7	16	2	3,5
20	52	16	10	50	18,0	18,0	40	21,7	24	2	7,0
25	60	16	10	58	23,5	21,0	48	21,7	24	2	7,0
30	70	20	14	68	27,0	25,0	55	29,7	40	2	7,0
40	85	25	14	83	36,0	32,0	63	29,7	40	3	7,0
50	100	32	16	98	45,0	37,0	78	35,7	48	3	8,0

Werkstoff: Legierter Einsatzstahl mit einer Zugfestigkeit im Kern von min. 950 N / mm². Einsatzgehärtet HRC 60 ± 2 (HV 700 ± 50), Härtetiefe 0,8 mm ± 0,2 mm, brüniert und präzisionsgeschliffen.

Ausführung: Mit innerer Kühlmittelzufuhr bzw. mit Gewindeanschluss für externe Kühlmittelzufuhr.

Material: Alloyed case-hardened steel, tensile core strength of min. 950 N / mm². Case hardened HRC 60 ± 2 (HV 700 ± 50), hardening depth 0.8 mm ± 0.2 mm, black-finished and precisely grinded.

Version: With internal coolant resp. with threaded connection for external coolant.

Matière: Acier de cémentation allié. Résistance à la traction dans le noyau de min 950 N / mm². Cémentation à HRC 60 ± 2 (HV 700 ± 50), profondeur de cémentation 0,8 mm ± 0,2 mm, bruni et rectifié précisément.

Version: Avec arrosage interne respectivement avec raccord fileté pour arrosage externe.

Werkzeugzuordnung für Scheibenrevolver

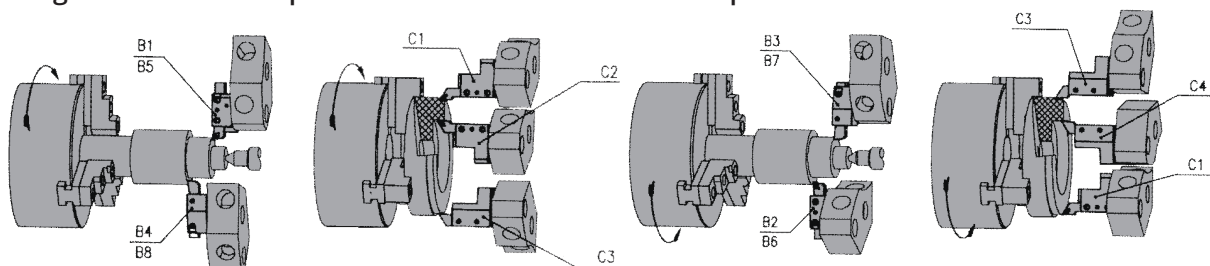

Tool assignment for disc turrets

Assignation des outils pour machines avec tourelle à disque



Einsatz von Werkzeughaltern bei linker Spindeldrehrichtung
 Application of tool holders with anti-clockwise spindle rotation
 Utilisation d'attachements avec la broche en sens anti-horaire

Einsatz von Werkzeughaltern bei rechter Spindeldrehrichtung
 Application of tool holders with clockwise spindle rotation
 Utilisation d'attachements avec la broche en sens horaire

 7.05 B1	 7.07 B2	 7.09 B3	 7.11 B4
 7.13 B5	 7.14 B6	 7.15 B7	 7.16 B8
 7.17 C1	 7.19 C2	 7.21 C3	 7.23 C4
 7.25 7.26 D1 D2	 7.27 7.28 AR AL	 7.29 E3	 7.30 E4
 7.31 E1	 7.32 E2	 7.33 E2	 7.36 E2
 7.37 E2	 7.39 F1	 7.40 Z2	 7.41 Z2
 7.43 E2	 7.45 F1	 7.47 7.48 A1 A2	 7.49 Z2
 7.50 - 7.57	 7.58 HAAS BMT 65	 7.58 HAAS BMT 65	 7.58 HAAS BMT 65
 7.58	 7.58 HAAS BMT 65	 7.58 HAAS BMT 65	 7.58 HAAS BMT 65

Radial toolholders form B1 right, short
 Porte-outils radials forme B1 droite, court

(DIN 69880)



Verwendung:
 Vorwiegend für Außenbearbeitung.
 Zum Plan Einstechen.

Application:
 Mainly for external machining.
 For face machining.

Application:
 Principalement pour usinage extérieur.
 Pour carottage.

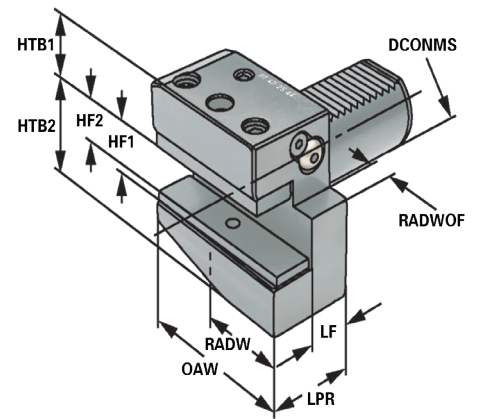

Bestell-Nr. Order no. Référence	Abmessung Size Dimension	DCONMS	HF1	HF2	LPR	LF	OAW	RADW	RADWOF	HTB1	HTB2
169.31.12	B1 - 16 × 12 × 24	16	12	-	24	13	42	23	5	20	22
209.31.16	B1 - 20 × 16 × 30	20	16	12	30	16	55	30	7	25	30
259.31.16	B1 - 25 × 16 × 30	25	16	12	30	16	55	30	7	25	30
309.31.20	B1 - 30 × 20 × 40	30	24,5	20,5	40	22	70	35	10	23,5	42,5
409.31.25	B1 - 40 × 25 × 44	40	28	23	44	22	85	42,5	12,5	30	50
509.31.32	B1 - 50 × 32 × 55	50	33	26	55	30	100	50	16	35	60

Ausführung: Mit einstellbarer Kugelspritzdüse und Unterlegplatte
Version: With adjustable spray nozzle and shim
Version: Avec gicleur ajustable et semelle

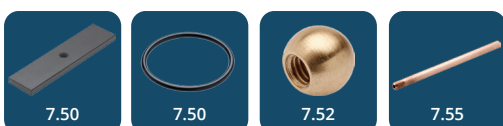

Radial toolholders form B1 right, short - for tools with internal coolant
 Porte-outils radials forme B1 droite, pour - outils avec arrosage interne



Verwendung:
 Vorwiegend für Außenbearbeitung.
 Zum Plan Einstechen.

Application:
 Mainly for external machining.
 For face machining.

Application:
 Principalement pour usinage extérieur.
 Pour carottage.

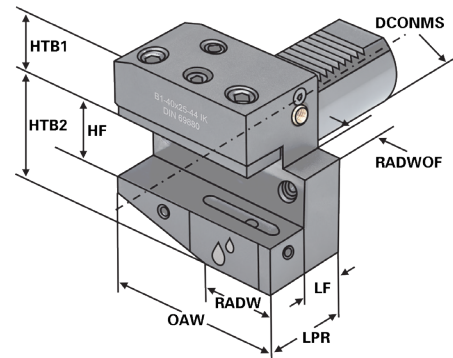

Bestell-Nr. Order no. Référence	Abmessung Size Dimension	DCONMS	HF	LPR	LF	OAW	RADW	RADWOF	HTB1	HTB2
309.31.20.IK	B1 - 30 × 20 × 40	30	20	40	22	70	35	10	28	38
409.31.25.IK	B1 - 40 × 25 × 44	40	25	44	22	85	42,5	12,5	32,5	48
509.31.32.IK	B1 - 50 × 32 × 55	50	32	55	30	100	50	16	35	60

Ausführung: Mit einstellbarer Kugelspritzdüse
Version: With adjustable spray nozzle
Version: Avec gicleur ajustable

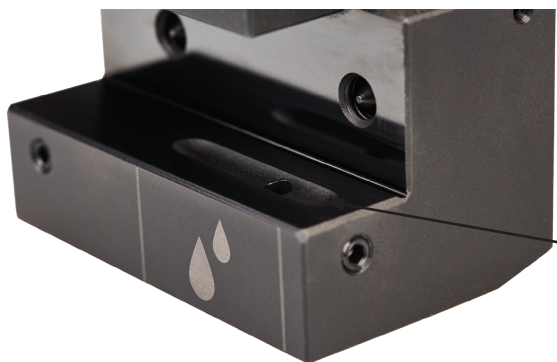

Übergabe für Kühlmittel
 Coolant supply
 Jonction d'arrosage

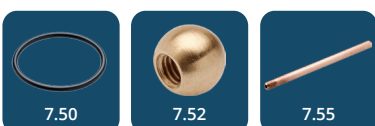

Radial toolholders form B2 left, short
 Porte-outils radials forme B2 gauche, court

(DIN 69880)



Verwendung:
 Vorwiegend für Außenbearbeitung.
 Zum Plan Einstechen.

Application:
 Mainly for external machining.
 For face machining.

Application:
 Principalement pour usinage extérieur.
 Pour carottage.

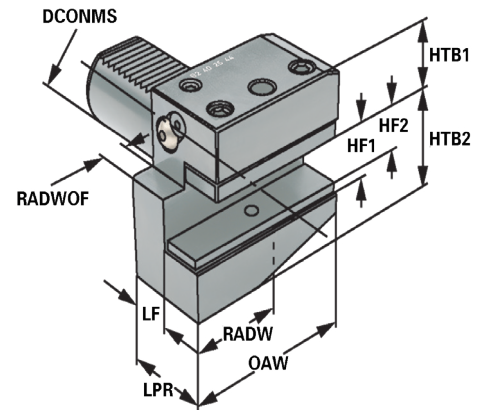

Bestell-Nr. Order no. Référence	Abmessung Size Dimension	DCONMS	HF1	HF2	LPR	LF	OAW	RADW	RADWOF	HTB1	HTB2
169.32.12	B2 - 16 × 12 × 24	16	12	-	24	13	42	23	5	20	22
209.32.16	B2 - 20 × 16 × 30	20	16	12	30	16	55	30	7	25	30
259.32.16	B2 - 25 × 16 × 30	25	16	12	30	16	55	30	7	25	30
309.32.20	B2 - 30 × 20 × 40	30	24,5	20,5	40	22	70	35	10	23,5	42,5
409.32.25	B2 - 40 × 25 × 44	40	28	23	44	22	85	42,5	12,5	30	50
509.32.32	B2 - 50 × 32 × 55	50	33	26	55	30	100	50	16	35	60

Ausführung: Mit einstellbarer Kugelspritzdüse und Unterlegplatte
Version: With adjustable spray nozzle and shim
Version: Avec gicleur ajustable et semelle



Radial toolholders form B2 left, short - for tools with internal coolant

Porte-outils radials forme B2 gauche, court - pour outils avec arrosage interne



Verwendung:
Vorwiegend für Außenbearbeitung.
Zum Plan Einstechen.

Application:
Mainly for external machining.
For face machining.

Application:
Principalement pour usinage extérieur.
Pour carottage.

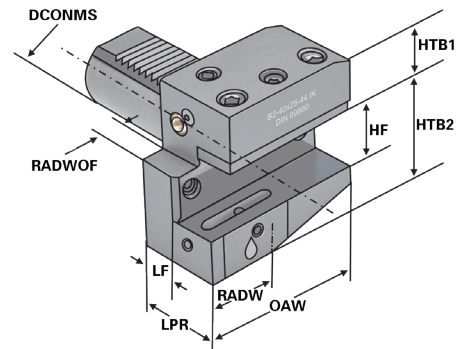

Bestell-Nr. Order no. Référence	Abmessung Size Dimension	DCONMS	HF	LPR	LF	OAW	RADW	RADWOF	HTB1	HTB2
309.32.20.IK	B2 - 30 × 20 × 40	30	20	40	22	70	35	10	28	38
409.32.25.IK	B2 - 40 × 25 × 44	40	25	44	22	85	42,5	12,5	32,5	48
509.32.32.IK	B2 - 50 × 32 × 55	50	32	55	30	100	50	16	35	60

Ausführung: Mit einstellbarer Kugelspritzdüse
Version: With adjustable spray nozzle
Version: Avec gicleur ajustable

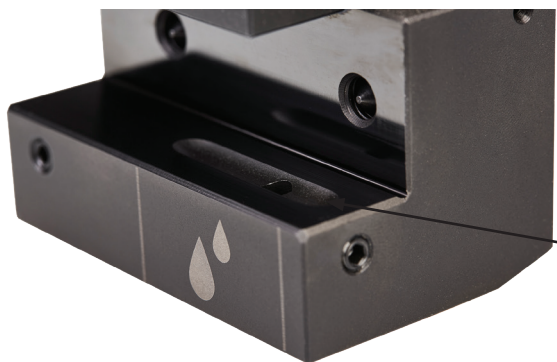

Übergabe für Kühlmittel
Coolant supply
Jonction d'arrosage

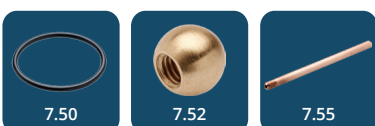

Radial toolholders form B3 overhead right, short
 Porte-outils radials forme B3 inversés droite, court

(DIN 69880)



Verwendung:
 Vorwiegend für Außenbearbeitung.
 Zum Plan Einstechen.

Application:
 Mainly for external machining.
 For face machining.

Application:
 Principalement pour usinage extérieur.
 Pour carottage.

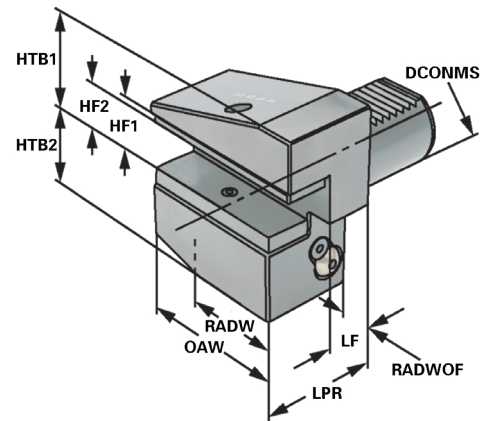

DIN ISO
10889

B3

Bestell-Nr. Order no. Référence	Abmessung Size Dimension	DCONMS	HF1	HF2	LPR	LF	OAW	RADW	RADWOF	HTB1	HTB2
169.33.12	B3 - 16 × 12 × 24	16	12	-	24	13	42	23	5	20	22
209.33.16	B3 - 20 × 16 × 30	20	16	12	30	16	55	30	7	25	30
259.33.16	B3 - 25 × 16 × 30	25	16	12	30	16	55	30	7	25	30
309.33.20	B3 - 30 × 20 × 40	30	25	20,5	40	22	70	35	10	30	43
409.33.25	B3 - 40 × 25 × 44	40	29	23	44	22	85	42,5	12,5	39,5	51
509.33.32	B3 - 50 × 32 × 55	50	34	26	55	30	100	50	16	49	61

Ausführung: Mit einstellbarer Kugelspritzdüse und Unterlegplatte
Version: With adjustable spray nozzle and shim
Version: Avec gicleur ajustable et semelle

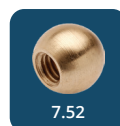

Radial toolholders form B3 overhead right, short - for tools with internal coolant
 Porte-outils radials forme B3 inversés droite, court - pour outils avec arrosage interne



Verwendung:
 Vorwiegend für Außenbearbeitung.
 Zum Plan Einstechen.

Application:
 Mainly for external machining.
 For face machining.

Application:
 Principalement pour usinage extérieur.
 Pour carottage.

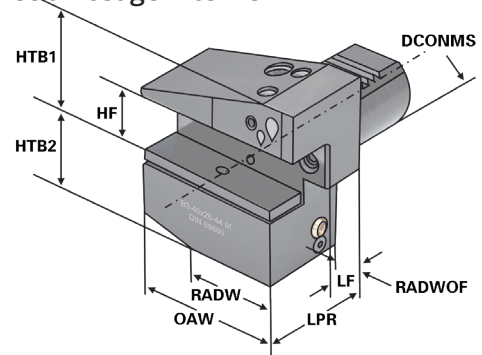

Bestell-Nr. Order no. Référence	Abmessung Size Dimension	DCONMS	HF	LPR	LF	OAW	RADW	RADWOF	HTB1	HTB2
309.33.20.IK	B3 - 30 × 20 × 40	30	20	40	22	70	35	10	35	38
409.33.25.IK	B3 - 40 × 25 × 44	40	25	44	22	85	42,5	12,5	42,5	48
509.33.32.IK	B3 - 50 × 32 × 55	50	32	55	30	100	50	16	50	60

Ausführung: Mit einstellbarer Kugelspritzdüse
Version: With adjustable spray nozzle
Version: Avec gicleur ajustable

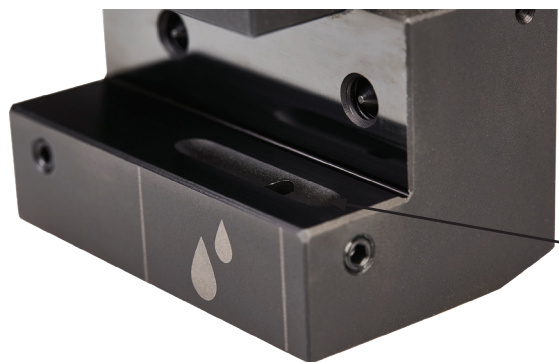

Übergabe für Kühlmittel
 Coolant supply
 Jonction d'arrosage

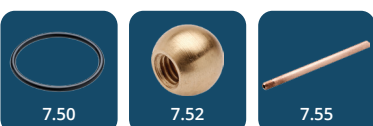

Radial toolholders form B4 overhead left, short
 Porte-outils radials forme B4 inversés gauche, court

(DIN 69880)



Verwendung:
 Vorwiegend für Außenbearbeitung.
 Zum Plan Einstechen.

Application:
 Mainly for external machining.
 For face machining.

Application:
 Principalement pour usinage extérieur.
 Pour carottage.

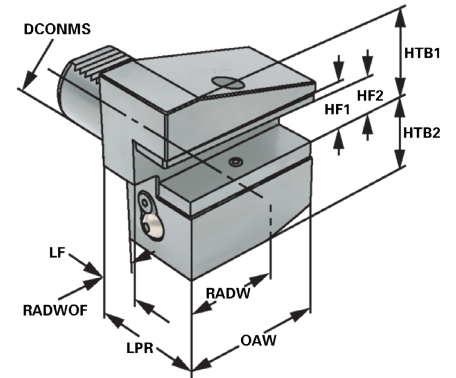

DIN ISO
10889

B4

Bestell-Nr. Order no. Référence	Abmessung Size Dimension	DCONMS	HF1	HF2	LPR	LF	OAW	RADW	RADWOF	HTB1	HTB2
169.34.12	B4 - 16 × 12 × 24	16	12	-	24	13	42	23	5	20	22
209.34.16	B4 - 20 × 16 × 30	20	16	12	30	16	55	30	7	35	30
259.34.16	B4 - 25 × 16 × 30	25	16	12	30	16	55	30	7	35	30
309.34.20	B4 - 30 × 20 × 40	30	25	20,5	40	22	70	35	10	30	42,5
409.34.25	B4 - 40 × 25 × 44	40	29	23	44	22	85	42,5	12,5	39,5	51
509.34.32	B4 - 50 × 32 × 55	50	34	26	55	30	100	50	16	49	61

Ausführung: Mit einstellbarer Kugelspritzdüse und Unterlegplatte
Version: With adjustable spray nozzle and shim
Version: Avec gicleur ajustable et semelle

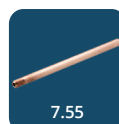
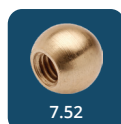

Radial toolholders form B4 overhead left, short - for tools with internal coolant

Porte-outils radials forme B4 inversés gauche, court - pour outils avec arrosage interne



Verwendung:
Vorwiegend für Außenbearbeitung.
Zum Plan Einstechen.

Application:
Mainly for external machining.
For face machining.

Application:
Principalement pour usinage extérieur.
Pour carottage.

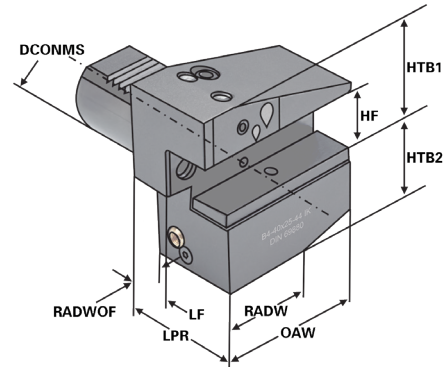

Bestell-Nr. Order no. Référence	Abmessung Size Dimension	DCONMS	HF	LPR	LF	OAW	RADW	RADWOF	HTB1	HTB2
309.34.20.IK	B4 - 30 × 20 × 40	30	20	40	22	70	35	10	35	38
409.34.25.IK	B4 - 40 × 25 × 44	40	25	44	22	85	42,5	12,5	42,5	48
509.34.32.IK	B4 - 50 × 32 × 55	50	32	55	30	100	50	16	50	60

Ausführung: Mit einstellbarer Kugelspritzdüse
Version: With adjustable spray nozzle
Version: Avec gicleur ajustable

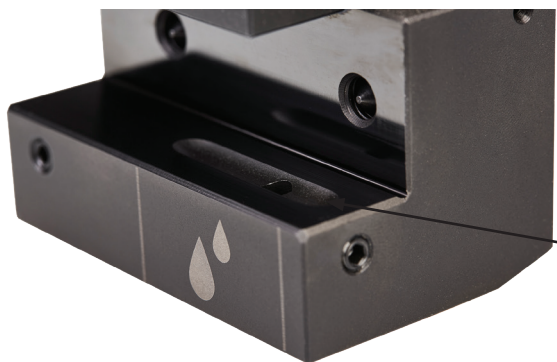

Übergabe für Kühlmittel
Coolant supply
Jonction d'arrosage

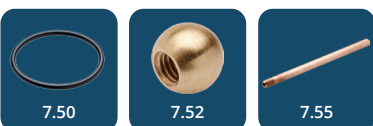

Radial toolholders form B5 right, long
 Porte-outils radials forme B5 droite, long

(DIN 69880)



Verwendung:
 Vorwiegend für Außenbearbeitung.
 Zum Plan Einstechen.

Application:
 Mainly for external machining.
 For face machining.

Application:
 Principalement pour usinage extérieur.
 Pour carottage.

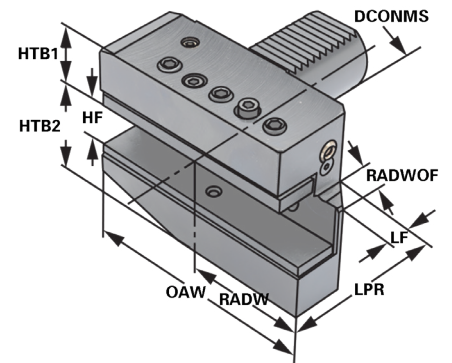

Bestell-Nr. Order no. Référence	Abmessung Size Dimension	DCONMS	OAW	RADW	RADWOF	LF	LPR	HF	HTB1	HTB2
169.35.12	B5 - 16 × 12 × 24	16	58	39	5	13	24	12	22	20
209.35.16	B5 - 20 × 16 × 30	20	75	50	7	16	30	16	25	30
259.35.16	B5 - 25 × 16 × 30	25	75	50	7	16	30	16	25	30
309.35.20	B5 - 30 × 20 × 40	30	100	65	10	22	40	20	28	38
409.35.25	B5 - 40 × 25 × 44	40	118	75,5	12,5	22	44	25	32,5	48
509.35.32	B5 - 50 × 32 × 55	50	130	85	16	30	55	32	35	60

Ausführung: Mit einstellbarer Kugelspritzdüse und Unterlegplatte
Version: With adjustable spray nozzle and shim
Version: Avec gicleur ajustable et semelle

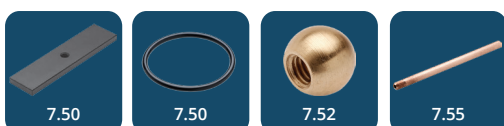

Radial toolholders form B6 left, long
 Porte-outils radials forme B6 gauche, long

(DIN 69880)



Verwendung:
 Vorwiegend für Außenbearbeitung.
 Zum Plan Einstechen.

Application:
 Mainly for external machining.
 For face machining.

Application:
 Principalement pour usinage extérieur.
 Pour carottage.

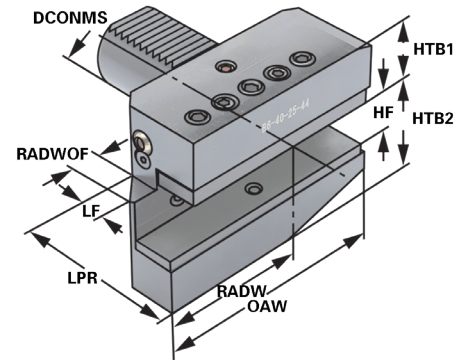

DIN ISO
10889

B6

Bestell-Nr. Order no. Référence	Abmessung Size Dimension	DCONMS	OAW	RADW	RADWOF	LF	LPR	HF	HTB1	HTB2
169.36.12	B6 - 16 × 12 × 24	16	58	39	5	13	24	12	22	20
209.36.16	B6 - 20 × 16 × 30	20	75	50	7	16	30	16	25	30
259.36.16	B6 - 25 × 16 × 30	25	75	50	7	16	30	16	25	30
309.36.20	B6 - 30 × 20 × 40	30	100	65	10	22	40	20	28	38
409.36.25	B6 - 40 × 25 × 44	40	118	75,5	12,5	22	44	25	32,5	48
509.36.32	B6 - 50 × 32 × 55	50	130	80	16	30	55	32	35	60

Ausführung: Mit einstellbarer Kugelspritzdüse und Unterlegplatte
Version: With adjustable spray nozzle and shim
Version: Avec gicleur ajustable et semelle

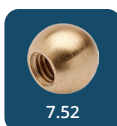
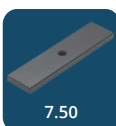

Radial toolholders form B7 overhead right, long
 Porte-outils radials forme B7 inversé droite, long

(DIN 69880)



Verwendung:
 Vorwiegend für Außenbearbeitung.
 Zum Plan Einstechen.

Application:
 Mainly for external machining.
 For face machining.

Application:
 Principalement pour usinage extérieur.
 Pour carottage.

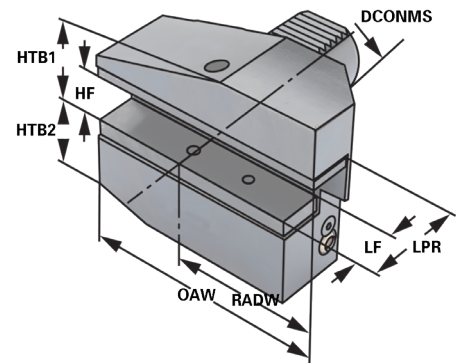

Bestell-Nr. Order no. Référence	Abmessung Size Dimension	DCONMS	OAW	RADW	RADWOF	LF	LPR	HF	HTB1	HTB2
169.37.12	B7 - 16 × 12 × 24	16	58	39	5	13	24	12	20	22
209.37.16	B7 - 20 × 16 × 30	20	75	50	7	16	30	16	30	25
259.37.16	B7 - 25 × 16 × 30	25	75	50	7	16	30	16	30	25
309.37.20	B7 - 30 × 20 × 40	30	100	65	10	22	40	20	42	30
409.37.25	B7 - 40 × 25 × 44	40	118	75,5	12,5	22	44	25	48	42,5
509.37.32	B7 - 50 × 32 × 55	50	130	80	16	30	55	32	60	50

Ausführung: Mit einstellbarer Kugelspritzdüse und Unterlegplatte
Version: With adjustable spray nozzle and shim
Version: Avec gicleur ajustable et semelle

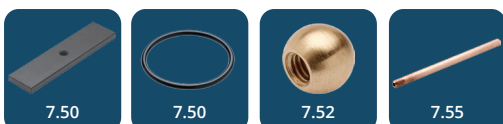

Radial toolholders form B8 overhead left, long
 Porte-outils radials forme B8 inversé gauche, long

(DIN 69880)



Verwendung:
 Vorwiegend für Außenbearbeitung.
 Zum Plan Einstechen.

Application:
 Mainly for external machining.
 For face machining.

Application:
 Principalement pour usinage extérieur.
 Pour carottage.

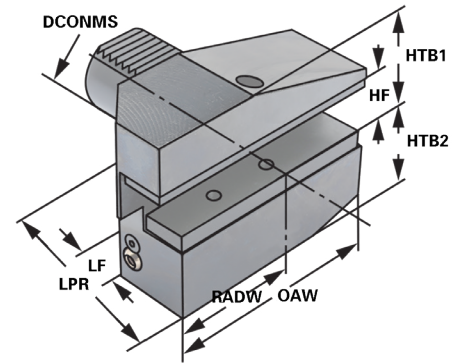

DIN ISO
10889

B8

Bestell-Nr. Order no. Référence	Abmessung Size Dimension	DCONMS	OAW	RADW	RADWOF	LF	LPR	HF	HTB1	HTB2
169.38.12	B8 - 16 × 12 × 24	16	58	39	5	13	24	12	20	22
209.38.16	B8 - 20 × 16 × 30	20	75	50	7	16	30	16	30	25
259.38.16	B8 - 25 × 16 × 30	25	75	50	7	16	30	16	30	25
309.38.20	B8 - 30 × 20 × 40	30	100	65	10	22	40	20	38	35
409.38.25	B8 - 40 × 25 × 44	40	118	75,5	12,5	22	44	25	48	42,5
509.38.32	B8 - 50 × 32 × 55	50	130	80	16	30	55	32	60	50

Ausführung: Mit einstellbarer Kugelspritzdüse und Unterlegplatte
Version: With adjustable spray nozzle and shim
Version: Avec gicleur ajustable et semelle

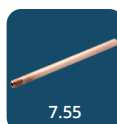
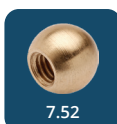



Verwendung:
Vorwiegend für Außenbearbeitung.
Zum Plan Einstechen.

Application:
Mainly for external machining.
For face machining.

Application:
Principalement pour usinage extérieur.
Pour carottage.

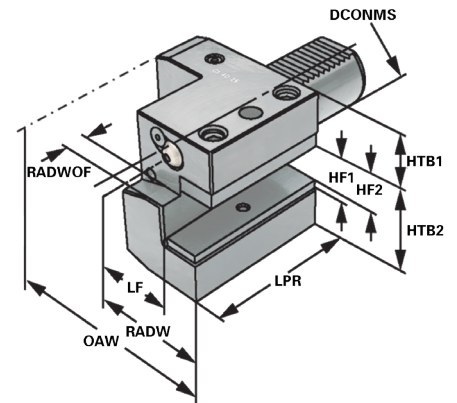

Bestell-Nr. Order no. Référence	Abmessung Size Dimension	DCONMS	HF1	HF2	OAW	RADH	LF	LPR	RADWOF	HTB1	HTB2
169.41.12	C1 - 16 × 12	16	12	10	43	24	13	44	5	20	22
209.41.16	C1 - 20 × 16	20	16	12	52	27	13	50	7	25	30
259.41.16	C1 - 25 × 16	25	16	12	58	33	19	55	7	25	30
309.41.20	C1 - 30 × 20	30	20	16	70	35	17	70	10	28	38
409.41.25	C1 - 40 × 25	40	25	20	85	42,5	21	85	12,5	32,5	48
509.41.32	C1 - 50 × 32	50	32	25	100	50	26	100	16	35	60

Ausführung: Mit einstellbarer Kugelspritzdüse und Unterlegplatte
Version: With adjustable spray nozzle and shim
Version: Avec gicleur ajustable et semelle

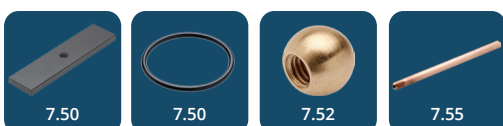

Axial toolholders form C1 right - for tools with internal coolant
 Porte-outils axials forme C1 droite - pour outils avec arrosage interne



Verwendung:
 Vorwiegend für Außenbearbeitung.
 Zum Plan Einstechen.

Application:
 Mainly for external machining.
 For face machining.

Application:
 Principalement pour usinage extérieur.
 Pour carottage.

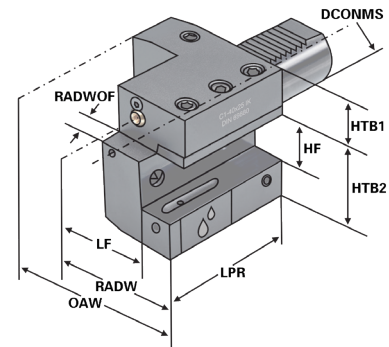

Bestell-Nr. Order no. Référence	Abmessung Size Dimension	DCONMS	HF	OAW	RADH	LF	LPR	RADWOF	HTB1	HTB2
309.41.20.IK	C1 - 30 × 20	30	20	76	49	31	70	10	24	42
409.41.25.IK	C1 - 40 × 25	40	25	90	55	33	85	12,5	32,5	48
509.41.32.IK	C1 - 50 × 32	50	32	105	62	38	100	16	35	60

Ausführung: Mit einstellbarer Kugelspritzdüse
Version: With adjustable spray nozzle
Version: Avec gicleur ajustable

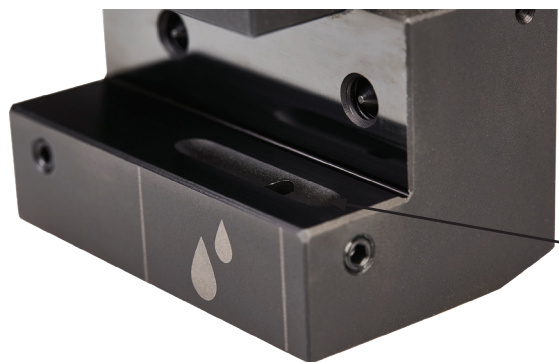

Übergabe für Kühlmittel
 Coolant supply
 Jonction d'arrosage

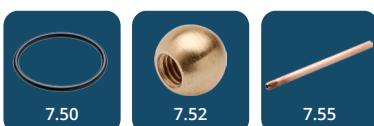

Axial toolholders form C2 left
 Porte-outils axials forme C2 gauche

(DIN 69880)



Verwendung:
 Vorwiegend für Außenbearbeitung.
 Zum Plan Einstechen.

Application:
 Mainly for external machining.
 For face machining.

Application:
 Principalement pour usinage extérieur.
 Pour carottage.

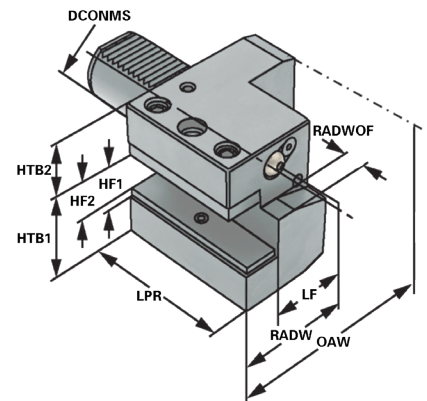

Bestell-Nr. Order no. Référence	Abmessung Size Dimension	DCONMS	HF1	HF2	OAW	RADH	LF	LPR	RADWOF	HTB1	HTB2
169.42.12	C2 - 16 × 12	16	12	-	43	24	13	44	5	20	22
209.42.16	C2 - 20 × 16	20	16	12	65	40	26	50	7	25	30
259.42.16	C2 - 25 × 16	25	16	12	58	33	26	55	7	20	30
309.42.20	C2 - 30 × 20	30	20	16	76	41	23	70	10	28	38
409.42.25	C2 - 40 × 25	40	25	20	90	47,5	25,5	85	12,5	32,5	48
509.42.32	C2 - 50 × 32	50	32	25	105	55	30,5	100	16	35	60

Ausführung: Mit einstellbarer Kugelspritzdüse und Unterlegplatte
Version: With adjustable spray nozzle and shim
Version: Avec gicleur ajustable et semelle

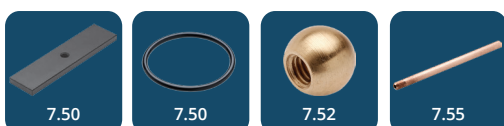

Axial toolholders form C2 left - for tools with internal coolant
 Porte-outils axials forme C2 gauche - pour outils avec arrosage interne



Verwendung:
 Vorwiegend für Außenbearbeitung.
 Zum Plan Einstechen.

Application:
 Mainly for external machining.
 For face machining.

Application:
 Principalement pour usinage extérieur.
 Pour carottage.

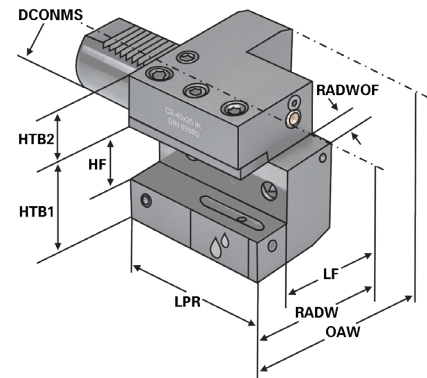

Bestell-Nr. Order no. Référence	Abmessung Size Dimension	DCONMS	HF	OAW	RADH	LF	LPR	RADWOF	HTB1	HTB2
309.42.20.IK	C2 - 30 × 20	30	20	76	49	31	70	10	24	42
409.42.25.IK	C2 - 40 × 25	40	25	90	55	33	85	12,5	32,5	48
509.42.32.IK	C2 - 50 × 32	50	32	105	62	38	100	16	35	60

Ausführung: Mit einstellbarer Kugelspritzdüse
Version: With adjustable spray nozzle
Version: Avec gicleur ajustable



Übergabe für Kühlmittel
 Coolant supply
 Jonction d'arrosage

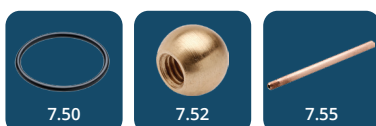

Axial toolholders form C3 overhead right, short
 Porte-outils axials forme C3 inversés droite, court

(DIN 69880)

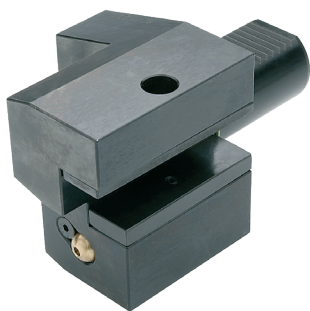

Verwendung:
 Vorwiegend für Außenbearbeitung.
 Zum Plan Einstechen.

Application:
 Mainly for external machining.
 For face machining.

Application:
 Principalement pour usinage extérieur.
 Pour carottage.

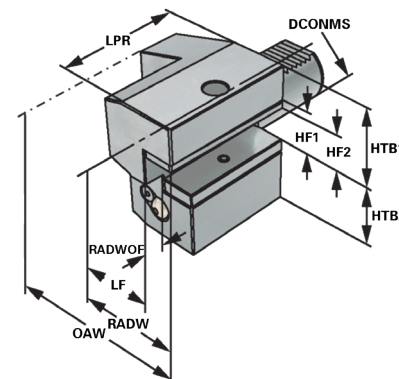

Bestell-Nr. Order no. Référence	Abmessung Size Dimension	DCONMS	HF1	HF2	OAW	RADH	LF	LPR	RADWOF	HTB1	HTB2
169.43.12	C3 - 16 × 12	16	12	10	43	24	13	44	5	20	22
209.43.16	C3 - 20 × 16	20	16	12	52	27	13	55	7	30	25
259.43.16	C3 - 25 × 16	25	16	12	58	33	19	55	7	30	25
309.43.20	C3 - 30 × 20	30	20	16	70	35	17	70	10	38	35
409.43.25	C3 - 40 × 25	40	25	20	85	42,5	21	85	12,5	48	42,5
509.43.32	C3 - 50 × 32	50	32	25	100	50	26	100	16	60	50

Ausführung: Mit einstellbarer Kugelspritzdüse und Unterlegplatte
Version: With adjustable spray nozzle and shim
Version: Avec gicleur ajustable et semelle

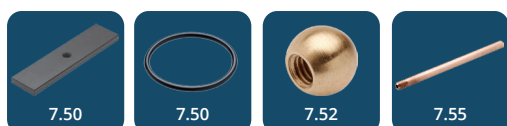

Axial toolholders form C3 overhead right - for tools with internal coolant

Porte-outils axials forme C3 inversés droite - pour outils avec arrosage interne



Verwendung:
Vorwiegend für Außenbearbeitung.
Zum Plan Einstechen.

Application:
Mainly for external machining.
For face machining.

Application:
Principalement pour usinage extérieur.
Pour carottage.

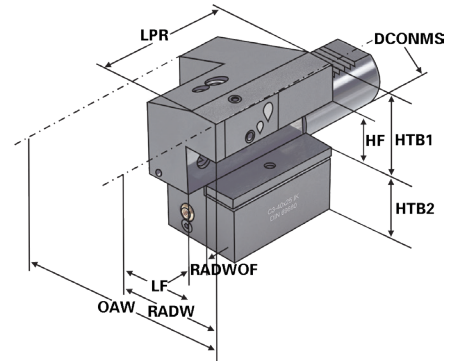

Bestell-Nr. Order no. Référence	Abmessung Size Dimension	DCONMS	HF	OAW	RADH	LF	LPR	RADWOF	HTB1	HTB2
309.43.20.IK	C3 - 30 × 20	30	20	70	35	17	70	10	38	35
409.43.25.IK	C3 - 40 × 25	40	25	85	42,5	21	85	12,5	48	42,5
509.43.32.IK	C3 - 50 × 32	50	32	100	50	26	100	16	60	50

Ausführung: Mit einstellbarer Kugelspritzdüse
Version: With adjustable spray nozzle
Version: Avec gicleur ajustable



Übergabe für Kühlmittel
Coolant supply
Jonction d'arrosage

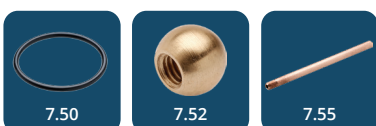

Axial toolholders form C4 overhead left, short
 Porte-outils axials forme C4 inversés gauche, court

(DIN 69880)



Verwendung:
 Vorwiegend für Außenbearbeitung.
 Zum Plan Einstechen.

Application:
 Mainly for external machining.
 For face machining.

Application:
 Principalement pour usinage extérieur.
 Pour carottage.

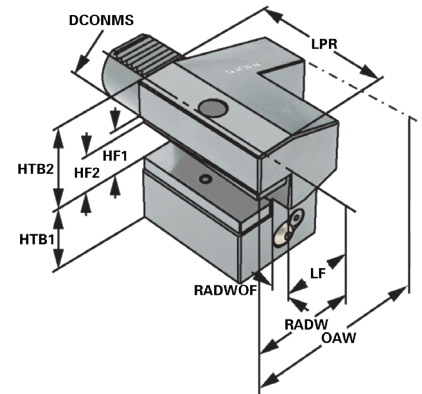

Bestell-Nr. Order no. Référence	Abmessung Size Dimension	DCONMS	HF1	HF2	OAW	RADH	LF	LPR	RADWOF	HTB1	HTB2
169.44.12	C4 - 16 × 12	16	12	10	43	24	13	44	5	22	20
209.44.16	C4 - 20 × 16	20	16	12	65	40	26	50	7	30	25
259.44.16	C4 - 25 × 16	25	16	12	58	33	19	55	7	30	25
309.44.20	C4 - 30 × 20	30	20	16	76	41	23	70	10	38	35
409.44.25	C4 - 40 × 25	40	25	20	90	47,5	25,5	85	12,5	48	42,5
509.44.32	C4 - 50 × 32	50	32	25	105	55	30,5	100	16	60	50

Ausführung: Mit einstellbarer Kugelspritzdüse und Unterlegplatte
Version: With adjustable spray nozzle and shim
Version: Avec gicleur ajustable et semelle

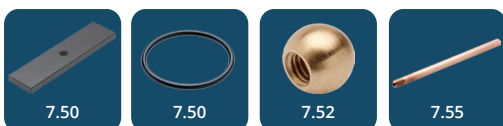

Axial toolholders form C4 overhead left - for tools with internal coolant

Porte-outils axials forme C4 inversés gauche - pour outils avec arrosage interne



Verwendung:
Vorwiegend für Außenbearbeitung.
Zum Plan Einstechen.

Application:
Mainly for external machining.
For face machining.

Application:
Principalement pour usinage extérieur.
Pour carottage.

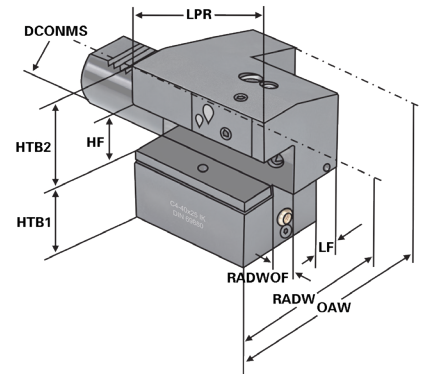

Bestell-Nr. Order no. Référence	Abmessung Size Dimension	DCONMS	HF	OAW	RADH	LF	LPR	RADWOF	HTB1	HTB2
309.44.20.IK	C4 - 30 × 20	30	20	70	35	17	70	10	38	35
409.44.25.IK	C4 - 40 × 25	40	25	85	42,5	21	85	12,5	48	42,5
509.44.32.IK	C4 - 50 × 32	50	32	100	50	26	100	16	60	50

Ausführung: Mit einstellbarer Kugelspritzdüse
Version: With adjustable spray nozzle
Version: Avec gicleur ajustable

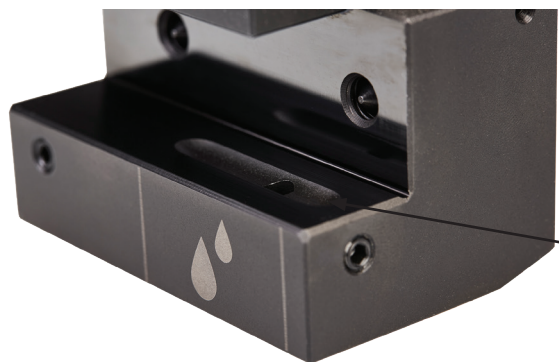

Übergabe für Kühlmittel
Coolant supply
Jonction d'arrosage

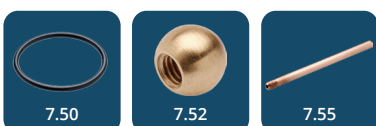

Rectangular toolholders with multiple seats form D1
 Porte-outils, multiple, forme D1

(DIN 69880)



Verwendung:
 Vorwiegend für Außenbearbeitung.
 Zum Plan Einstechen.

Application:
 Mainly for external machining.
 For face machining.

Application:
 Principalement pour usinage extérieur.
 Pour carottage.

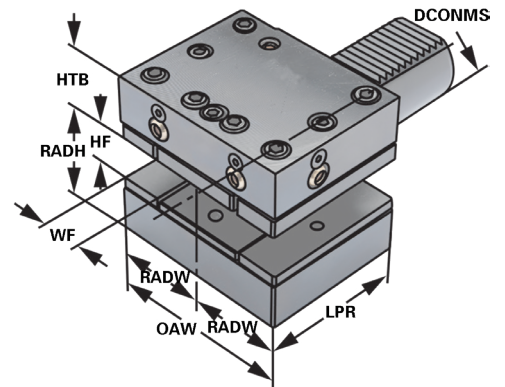

Bestell-Nr. Order no. Référence	Abmessung Size Dimension	DCONMS	OAW	RADW	WF	LPR	HF	HTB	RADH
309.89.12	D1 - 30 x 20 x 60	30	76	41	18	60	20	28	38
409.89.16	D1 - 40 x 25 x 72	40	90	47,5	22	72	25	32,5	48
509.89.20	D1 - 50 x 32 x 85	50	105	55	24,5	85	32	35	60

Ausführung: Mit einstellbarer Kugelspritzdüse und Unterlegplatte
Version: With adjustable spray nozzle and shim
Version: Avec gicleur ajustable et semelle

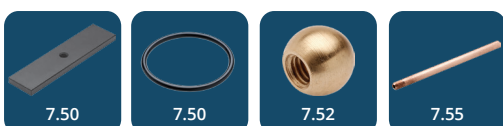



Verwendung:
 Vorwiegend für Außenbearbeitung.
 Zum Plan Einstechen.

Application:
 Mainly for external machining.
 For face machining.

Application:
 Principalement pour usinage extérieur.
 Pour carottage.

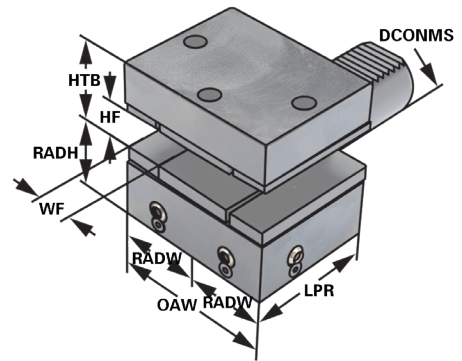

Bestell-Nr. Order no. Référence	Abmessung Size Dimension	DCONMS	OAW	RADW	WF	LPR	HF	HTB	RADH
309.90.12	D2 - 30 × 20 × 60	30	76	41	18	60	20	35	38
409.90.16	D2 - 40 × 25 × 72	40	90	47,5	22	72	25	42,5	48
509.90.20	D2 - 50 × 32 × 85	50	105	55	24,5	85	32	50	60

Ausführung: Mit einstellbarer Kugelspritzdüse und Unterlegplatte
Version: With adjustable spray nozzle and shim
Version: Avec gicleur ajustable et semelle





Verwendung:
 Vorwiegend für Außenbearbeitung.
 Zum Plan Einstechen.

Application:
 Mainly for external machining.
 For face machining.

Application:
 Principalement pour usinage extérieur.
 Pour carottage.

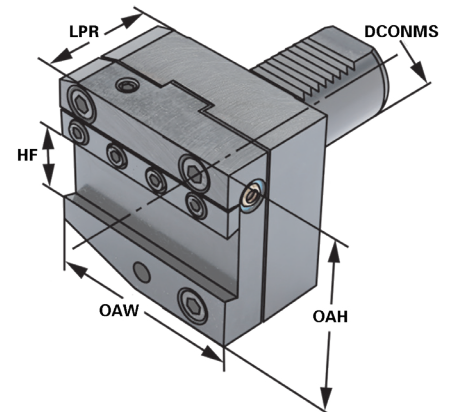

Bestell-Nr. Order no. Référence	Abmessung Size Dimension	DCONMS	OAW	OAH	LPR	HF
309.65.26	AR - 30 × 26	30	70	70	50	26
409.65.32	AR - 40 × 32	40	85	80	50	32
509.65.32	AR - 50 × 32	50	100	80	50	32

Ausführung: Mit einstellbarer Kugelspritzdüse
Version: With adjustable spray nozzle
Version: Avec gicleur ajustable

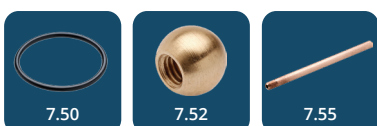

Parting-off toolholders left height adjustable
 Porte-lames de tronçonnage gauche réglage en hauteur

(DIN 69880)



Verwendung:
 Vorwiegend für Außenbearbeitung.
 Zum Plan Einstechen.

Application:
 Mainly for external machining.
 For face machining.

Application:
 Principalement pour usinage extérieur.
 Pour carottage.

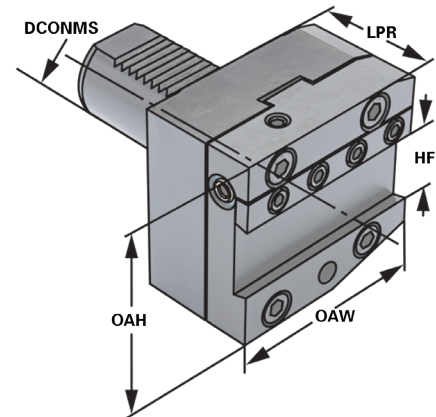

DIN ISO
10889

AL

Bestell-Nr. Order no. Référence	Abmessung Size Dimension	DCONMS	OAW	OAH	LPR	HF
309.66.26	AL - 30 × 26	30	70	70	50	26
409.66.32	AL - 40 × 32	40	85	80	50	32
509.66.32	AL - 50 × 32	50	100	80	50	32

Ausführung: Mit einstellbarer Kugelspritzdüse
Version: With adjustable spray nozzle
Version: Avec gicleur ajustable

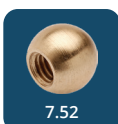

Collet chucks form E3 DIN 6391 for collets ISO 10897 (DIN 6388) OZ-system
Mandrins à pinces forme E3 DIN 6391 pour pinces ISO 10897 (DIN 6388) système OZ

**Verwendung:**

Zur Aufnahme von Werkzeugen mit Zylinderschaft in Spannzangen.

Application:

For mounting straight-shank tools in collets.

Application:

Pour le serrage d'outils avec queue cylindrique dans des pinces de serrage.

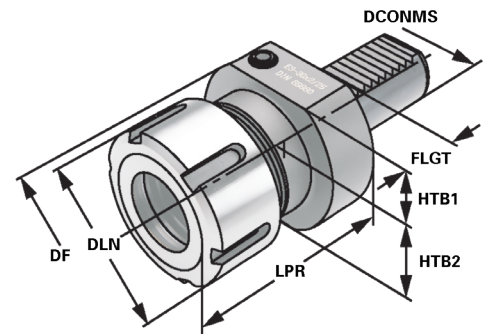
DIN ISO
10889

E3

ISO
10897

13.04

Bestell-Nr. Order no. Référence	Abmessung Size Dimension	DCONMS	DCONWS Spannbereich Capacity Cap.	Typ	DF	DLN	HTB1	HTB2	LPR	FLGT
169.01.16	E3 - 16 × 2 - 16	16	2 - 16	415E OZ 16	40	43	18	18	45,5	13
209.01.16	E3 - 20 × 2 - 16	20	2 - 16	415E OZ 16	50	43	25	23	57	18
259.01.16	E3 - 25 × 2 - 16	25	2 - 16	415E OZ 16	58	43	25	25	57	18
309.01.16	E3 - 30 × 2 - 16	30	2 - 16	415E OZ 16	68	43	28	30	57	22
309.01.25	E3 - 30 × 2 - 25	30	2 - 25	462E OZ 25	68	60	28	30	75	22
409.01.25	E3 - 40 × 2 - 25	40	2 - 25	462E OZ 25	83	60	32,5	41,5	75	22
409.01.32	E3 - 40 × 3 - 32	40	3 - 32	467E OZ 32	83	72	32,5	41,5	90	22
509.01.25	E3 - 50 × 2 - 25	50	2 - 25	462E OZ 25	98	60	35	49	75	30
509.01.32	E3 - 50 × 3 - 32	50	3 - 32	467E OZ 32	98	72	35	49	90	30

Lieferumfang: Mit kugellagerter Spannmutter
Delivery: With ball bearing clamping nut
Livraison: Avec écrou de serrage à roulement à billes

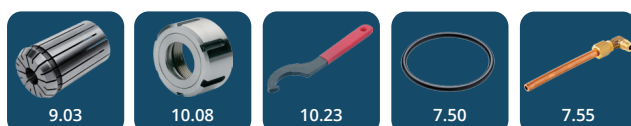

Collet chucks form E4 for collets ISO 15488 (DIN 6499) ER-system
Mandrins à pinces forme E4 pour pinces ISO 15488 (DIN 6499) système ER



Verwendung:
Zur Aufnahme von Werkzeugen mit Zylinderschaft in Spannzangen.

Application:
For mounting straight-shank tools in collets.

Application:
Pour le serrage d'outils avec queue cylindrique dans des pinces de serrage.

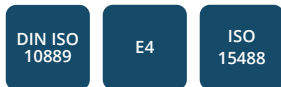
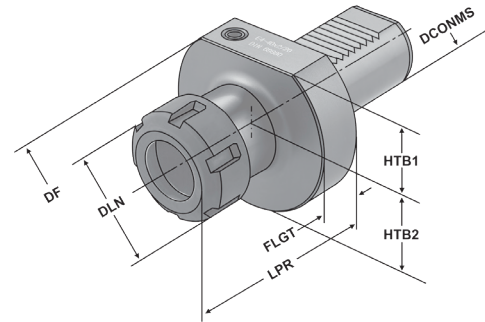

Bestell-Nr. Order no. Référence	Abmessung Size Dimension	DCONMS	DCONWS Spannbereich Capacity Cap.	Typ	DF	DLN	HTB1	HTB2	LPR	FLGT
169.02.10	E4 - 16 × 1 - 10	16	1 - 10	426E ER 16	40	28	18	18	40	13
209.02.10	E4 - 20 × 1 - 10	20	1 - 10	426E ER 16	50	28	25	23	42	18
209.02.16	E4 - 20 × 2 - 16	20	2 - 16	430E ER 25	50	42	25	23	46	18
259.02.16	E4 - 25 × 2 - 16	25	2 - 16	430E ER 25	58	42	25	25	55	18
259.02.20	E4 - 25 × 2 - 20	25	2 - 20	470E ER 32	58	50	25	25	55	18
309.02.16	E4 - 30 × 2 - 16	30	2 - 16	430E ER 25	68	42	28	30	57	22
309.02.20	E4 - 30 × 2 - 20	30	2 - 20	470E ER 32	68	50	28	30	75	22
309.02.26	E4 - 30 × 3 - 26	30	3 - 26	472E ER 40	68	63	28	30	75	22
409.02.16	E4 - 40 × 2 - 16	40	2 - 16	430E ER 25	83	42	32,5	41,5	75	22
409.02.20	E4 - 40 × 2 - 20	40	2 - 20	470E ER 32	83	50	32,5	41,5	75	22
409.02.26	E4 - 40 × 3 - 26	40	3 - 26	472E ER 40	83	63	32,5	41,5	75	22
509.02.26	E4 - 50 × 3 - 26	50	3 - 26	472E ER 40	98	63	35	49	75	30

Lieferumfang: Mit gewuchteter Spannmutter
Delivery: With balanced clamping nut
Livraison: Avec écrou de serrage équilibré



Boring holders for drills with indexable inserts form E1
 Portes forets pour forets à plaquettes réversibles forme E1

(DIN 69880)



Verwendung:
 Zur Aufnahme von allen nach DIN 6595 genormten Vollbohrern mit Zylinder-schaft.

Application:
 For all solid drills with cylindrical shank according to DIN 6595.

Application:
 Pour le serrage de forets à queue cylindrique suivant DIN 6595.

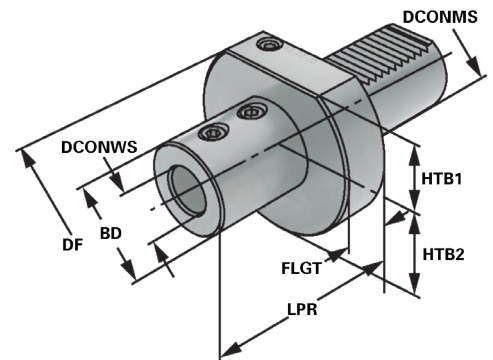

Bestell-Nr. Order no. Référence	Abmessung Size Dimension	DCONMS	DCONWS	BD	DF	HTB1	HTB2	LPR	FLGT
209.51.16	E1 - 20 × 16	20	16	40	50	22	22	67	18
209.51.20	E1 - 20 × 20	20	20	40	50	22	22	67	18
209.51.25	E1 - 20 × 25	20	25	45	50	22	22	71	18
259.51.16	E1 - 25 × 16	25	16	40	58	25	25	67	18
259.51.20	E1 - 25 × 20	25	20	40	58	25	25	67	18
259.51.25	E1 - 25 × 25	25	25	45	58	25	25	71	18
259.51.32	E1 - 25 × 32	25	32	58	58	25	25	78	-
309.51.16	E1 - 30 × 16	30	16	36	68	28	30	64	22
309.51.20	E1 - 30 × 20	30	20	40	68	28	30	67	22
309.51.25	E1 - 30 × 25	30	25	45	68	28	30	71	22
309.51.32	E1 - 30 × 32	30	32	52	68	28	30	75	22
309.51.40	E1 - 30 × 40	30	40	60	68	28	30	95	22
409.51.16	E1 - 40 × 16	40	16	36	83	32,5	41,5	64	22
409.51.20	E1 - 40 × 20	40	20	40	83	32,5	41,5	67	22
409.51.25	E1 - 40 × 25	40	25	45	83	32,5	41,5	75	22
409.51.32	E1 - 40 × 32	40	32	52	83	32,5	41,5	75	22
409.51.40	E1 - 40 × 40	40	40	65	83	32,5	41,5	90	22
509.51.16	E1 - 50 × 16	50	16	40	98	35	49	66	30
509.51.20	E1 - 50 × 20	50	20	40	98	35	49	66	30
509.51.25	E1 - 50 × 25	50	25	45	98	35	49	80	30
509.51.32	E1 - 50 × 32	50	32	52	98	35	49	80	30
509.51.40	E1 - 50 × 40	50	40	65	98	35	49	90	30
509.51.50	E1 - 50 × 50	50	50	75	98	35	49	100	30

Lieferumfang: Mit Spannschrauben
Delivery: With clamping screws
Livraison: Avec vis de serrage



Drill chuck adaptors DIN 238

(DIN 69880)

Arbres pour mandrins de perçage DIN 238

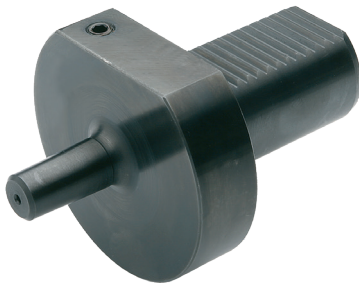

Verwendung:
Zur Aufnahme von Bohrfuttern.
Application:
For mounting drill chucks.
Application:
Pour le serrage de mandrins de perçage.

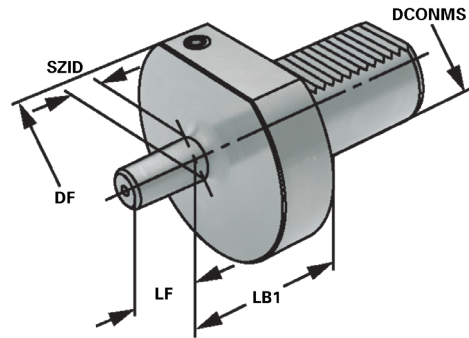

DIN ISO
10889

DIN
238

Bestell-Nr. Order no. Référence	Abmessung Size Dimension	DCONMS	SZID	DF	LB1	LF
309.14.16	30 - B16	30	B16	68	27	24
409.14.16	40 - B16	40	B16	83	27	24
509.14.16	50 - B16	50	B16	98	35	24

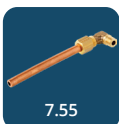



Verwendung:
Für Innenbearbeitung mit Bohrstangen.

Application:
For internal machining with boring bars.

Application:
Pour l'usinage intérieur avec barres d'alésage.

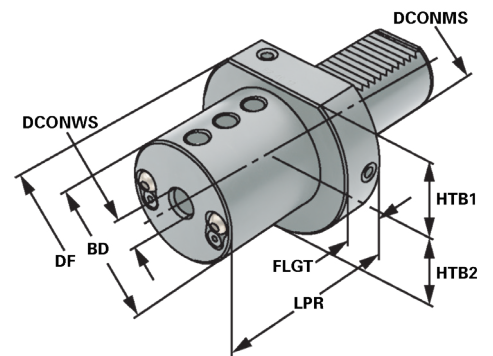
DIN ISO
10889

E2

Bestell-Nr. Order no. Référence	Abmessung Size Dimension	DCONMS	DCONWS	DF	BD	HTB1	HTB2	LPR	FLGT
169.52.06	E2 - 16 × 06	16	6	40	32	18	20	44	13
169.52.08	E2 - 16 × 08	16	8	40	32	18	20	44	13
169.52.10	E2 - 16 × 10	16	10	40	32	18	20	44	13
169.52.12	E2 - 16 × 12	16	12	40	32	18	20	44	13
169.52.16	E2 - 16 × 16	16	16	40	32	18	20	44	13
209.52.08	E2 - 20 × 08	20	8	50	40	23	25	50	18
209.52.10	E2 - 20 × 10	20	10	50	40	23	25	50	18
209.52.12	E2 - 20 × 12	20	12	50	40	23	25	50	18
209.52.16	E2 - 20 × 16	20	16	50	40	23	25	50	18
209.52.20	E2 - 20 × 20	20	20	50	40	23	25	50	18
259.52.08	E2 - 25 × 08	25	8	58	40	25	25	50	18
259.52.10	E2 - 25 × 10	25	10	58	40	25	25	50	18
259.52.12	E2 - 25 × 12	25	12	58	40	25	25	50	18
259.52.16	E2 - 25 × 16	25	16	58	40	25	25	50	18
259.52.20	E2 - 25 × 20	25	20	58	58	25	25	50	-
259.52.25	E2 - 25 × 25	25	25	58	58	25	25	60	-

Ausführung: Mit einstellbaren Kugelspritzdüsen
Version: With adjustable spray nozzles
Version: Avec gicleurs ajustables

Lieferumfang: Mit Spannschrauben
Delivery: With clamping screws
Livraison: Avec vis de serrage



Boring bar holders form E2

(DIN 69880)

Porte-outils pour barres d'alésage forme E2



Verwendung:
Für Innenbearbeitung mit Bohrstangen.

Application:
For internal machining with boring bars.

Application:
Pour l'usinage intérieur avec barres d'alésage.

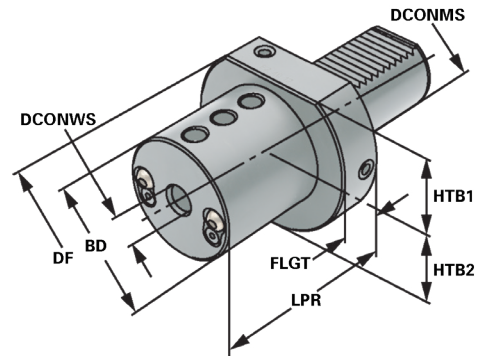

Bestell-Nr. Order no. Référence	Abmessung Size Dimension	DCONMS	DCONWS	DF	BD	HTB1	HTB2	LPR	FLGT
309.52.08	E2 - 30 × 08	30	8	68	55	28	30	60	22
309.52.10	E2 - 30 × 10	30	10	68	55	28	30	60	22
309.52.12	E2 - 30 × 12	30	12	68	55	28	30	60	22
309.52.16	E2 - 30 × 16	30	16	68	55	28	30	60	22
309.52.20	E2 - 30 × 20	30	20	68	55	28	30	60	22
309.52.25	E2 - 30 × 25	30	25	68	55	28	30	60	22
309.52.32	E2 - 30 × 32	30	32	68	68	28	30	75	-
409.52.08	E2 - 40 × 08	40	8	83	55	32,5	41,5	75	22
409.52.10	E2 - 40 × 10	40	10	83	55	32,5	41,5	75	22
409.52.12	E2 - 40 × 12	40	12	83	55	32,5	41,5	75	22
409.52.16	E2 - 40 × 16	40	16	83	55	32,5	41,5	75	22
409.52.20	E2 - 40 × 20	40	20	83	55	32,5	41,5	75	22
409.52.25	E2 - 40 × 25	40	25	83	55	32,5	41,5	75	22
409.52.32	E2 - 40 × 32	40	32	83	83	32,5	41,5	75	-
409.52.40	E2 - 40 × 40	40	40	83	83	32,5	41,5	90	-
509.52.12	E2 - 50 × 12	50	12	98	68	35	49	90	30
509.52.16	E2 - 50 × 16	50	16	98	68	35	49	90	30
509.52.20	E2 - 50 × 20	50	20	98	68	35	49	90	30
509.52.25	E2 - 50 × 25	50	25	98	68	35	49	90	30
509.52.32	E2 - 50 × 32	50	32	98	68	35	49	90	30
509.52.40	E2 - 50 × 40	50	40	98	98	35	49	90	-
509.52.50	E2 - 50 × 50	50	50	98	98	35	49	100	-

Ausführung: Mit einstellbaren Kugelspritzdüsen
Version: With adjustable spray nozzles
Version: Avec gicleurs ajustables

Lieferumfang: Mit Spannschrauben
Delivery: With clamping screws
Livraison: Avec vis de serrage



Boring bar holders form E2 | Clamping possible on both sides

(DIN 69880)

Porte-outils pour barres d'alésage forme E2 | Possibilité de serrage des deux côtés



Verwendung:
Für Innenbearbeitung mit Bohrstangen.

Application:
For internal machining with boring bars.

Application:
Pour l'usinage intérieur avec barres d'alésage.

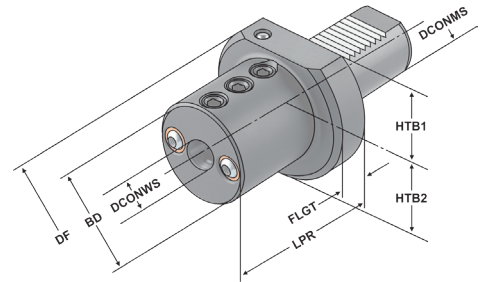

DIN ISO 10889

E2

Bestell-Nr. Order no. Référence	Abmessung Size Dimension	DCONMS	DCONWS	DF	BD	HTB1	HTB2	LPR	FLGT
309.53.10	E2 - 30 × 10	30	10	68	50	28	30	60	22
309.53.12	E2 - 30 × 12	30	12	68	50	28	30	60	22
309.53.16	E2 - 30 × 16	30	16	68	55	28	30	60	22
309.53.20	E2 - 30 × 20	30	20	68	55	28	30	60	22
309.53.25	E2 - 30 × 25	30	25	68	55	28	30	60	22
309.53.32	E2 - 30 × 32	30	32	68	68	28	30	65	-
409.53.08	E2 - 40 × 08	40	8	83	50	32,5	41,5	75	22
409.53.10	E2 - 40 × 10	40	10	83	50	32,5	41,5	75	22
409.53.12	E2 - 40 × 12	40	12	83	50	32,5	41,5	75	22
409.53.16	E2 - 40 × 16	40	16	83	55	32,5	41,5	75	22
409.53.20	E2 - 40 × 20	40	20	83	55	32,5	41,5	75	22
409.53.25	E2 - 40 × 25	40	25	83	60	32,5	41,5	75	22
409.53.32	E2 - 40 × 32	40	32	83	72	32,5	41,5	75	-
409.53.40	E2 - 40 × 40	40	40	83	83	32,5	41,5	85	-

Ausführung: Mit einstellbaren Kugelspritzdüsen
Version: With adjustable spray nozzles
Version: Avec gicleurs ajustables

Lieferumfang: Mit Spannschrauben
Delivery: With clamping screws
Livraison: Avec vis de serrage



Spannmöglichkeit beidseitig
Clamping possible on both sides
Possibilité de serrage des deux côtés



Boring bar holders form E2 slotted

(DIN 69880)

Porte-outils pour barres d'alésage forme E2 pour barre d'alésage fendu



Verwendung:
Für Innenbearbeitung mit Bohrstangen.

Application:
For internal machining with boring bars.

Application:
Pour l'usinage intérieur avec barres d'alésage.

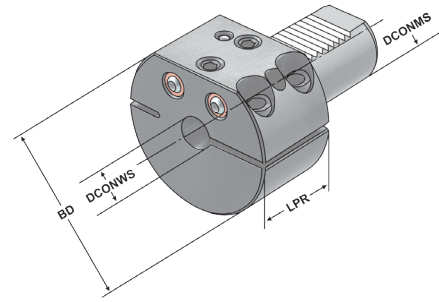
DIN ISO
10889

E2

Bestell-Nr. Order no. Référence	Abmessung Size Dimension	DCONMS	DCONWS	BD	LPR
309.55.16	E2 - 30 × 16	30	16	68	42
309.55.20	E2 - 30 × 20	30	20	68	42
409.55.16	E2 - 40 × 16	40	16	83	46
409.55.20	E2 - 40 × 20	40	20	83	46
409.55.25	E2 - 40 × 25	40	25	83	46
409.55.32	E2 - 40 × 32	40	32	83	90

Ausführung: Mit einstellbaren Kugelspritzdüsen
Version: *With adjustable spray nozzles*
Version: Avec gicleurs ajustables

Lieferumfang: Mit Spannschrauben
Delivery: *With clamping screws*
Livraison: Avec vis de serrage



Reduction sleeves for boring bar holders form E2
 Douilles de réduction pour barres d'alésage forme E2

(DIN 69880)



Form 1



Form 2

Verwendung:

Reduzierung zum Spannen von Werkzeugen mit Zylinderschaft, wie z. B. Feindreh-Bohrstangen.

Application:

Reduction for mounting tools with straight-shank, such as precision boring bars.

Application:

Réduction pour le serrage d'outils avec queue cylindrique, p. ex. barres d'alésage pour tournage de finition.

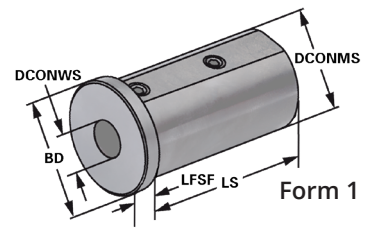

Form 1

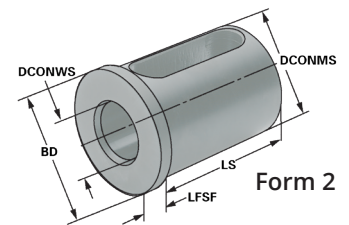

Form 2



Bestell-Nr. Order no. Référence	Form form forme	DCONMS	DCONWS	LS	LFSF	BD	OAL
709.25.06	1	25	6	46	5	29	51
709.25.08	1	25	8	46	5	29	51
709.25.10	1	25	10	46	5	29	51
709.25.12	1	25	12	46	5	29	51
709.25.14	1	25	14	46	5	29	51
709.25.16	2	25	16	46	5	29	51
709.25.18	2	25	18	46	5	29	51
709.25.20	2	25	20	46	5	29	51
709.32.06	1	32	6	55	5	36	60
709.32.08	1	32	8	55	5	36	60
709.32.10	1	32	10	55	5	36	60
709.32.12	1	32	12	55	5	36	60
709.32.14	1	32	14	55	5	36	60
709.32.16	2	32	16	55	5	36	60
709.32.18	2	32	18	55	5	36	60
709.32.20	2	32	20	55	5	36	60
709.32.25	2	32	25	55	5	36	60
709.40.06	1	40	6	71	5	44	76
709.40.08	1	40	8	71	5	44	76
709.40.10	1	40	10	71	5	44	76
709.40.12	1	40	12	71	5	44	76
709.40.14	1	40	14	71	5	44	76
709.40.16	2	40	16	71	5	44	76
709.40.18	2	40	18	71	5	44	76
709.40.20	2	40	20	71	5	44	76
709.40.25	2	40	25	71	5	44	76
709.40.32	2	40	32	71	5	44	76

Hinweis: Geeignet für Innenkühlung (nicht geschlitzt)
Note: Suitable for through-coolant (not slotted)
Observation: Convenable pour arrosage interne (non fendu)



10.104

Reduction sleeves set for boring bar holders form E2
 Douilles de réduction jeux pour barres d'alésage forme E2

(DIN 69880)



Verwendung:
 Reduzierung zum Spannen von Werkzeugen mit Zylinderschaft, wie z. B. Feindreh-Bohrstangen.

Application:
 Reduction for mounting tools with straight-shank, such as precision boring bars.

Application:
 Réduction pour le serrage d'outils avec queue cylindrique, p. ex. barres d'alésage pour tournage de finition.

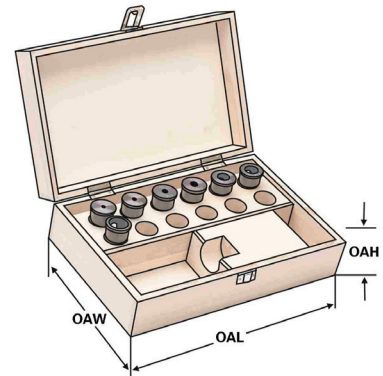

Bestell-Nr. Order no. Référence	Abmessung Size Dimension	OAL	OAW	OAH
701.709.25-S	Ø 25 Set 6 St. 06-08-10-12-16-20	360	235	70
701.709.32-S	Ø 32 Set 7 St. 06-08-10-12-16-20-25	360	235	70
701.709.40-S	Ø 40 Set 8 St. 06-08-10-12-16-20-25-32	360	235	70



Adaptor sleeves for MT, tanged, form F1
 Douilles de réduction pour CM à tenon forme F1

(DIN 69880)



Verwendung:
 Zur Aufnahme von Werkzeugen mit Morsekegelschaft und Austreibblappen nach DIN 228-1 Form B.

Application:
 For holding tools with Morse taper shank and tang according to DIN 228-1 form B.

Application:
 Pour le serrage d'outils avec queue cône Morse et tenon suivant DIN 228-1 forme B.

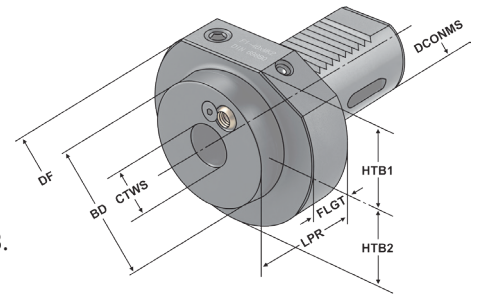

Bestell-Nr. Order no. Référence	Abmessung Size Dimension	DCONMS	CTWS	BD	DF	LPR	FLGT	HTB1	HTB2
169.07.01	F1 - 16 × MK 1	16	1	32	40	32	13	18	18
209.07.01	F1 - 20 × MK 1	20	1	-	50	23	-	22	23
209.07.02	F1 - 20 × MK 2	20	2	40	50	90	-	22	23
259.07.01	F1 - 25 × MK 1	25	1	-	58	23	-	25	25
259.07.02	F1 - 25 × MK 2	25	2	-	58	27	-	25	25
309.07.01	F1 - 30 × MK 1	30	1	-	68	27	-	28	30
309.07.02	F1 - 30 × MK 2	30	2	-	68	27	-	28	30
309.07.03	F1 - 30 × MK 3	30	3	58	68	75	22	28	30
409.07.02	F1 - 40 × MK 2	40	2	55	83	36	22	32,5	50,5
409.07.03	F1 - 40 × MK 3	40	3	55	83	36	22	32,5	50,5
409.07.04	F1 - 40 × MK 4	40	4	68	83	80	22	32,5	50,5
509.07.02	F1 - 50 × MK 2	50	2	55	98	36	30	35	49
509.07.03	F1 - 50 × MK 3	50	3	58	98	36	30	35	49
509.07.04	F1 - 50 × MK 4	50	4	68	98	50	30	35	49
509.07.05	F1 - 50 × MK 5	50	5	98	98	168	-	35	49

Ausführung: Mit einstellbaren Kugelspritzdüsen
Version: With adjustable spray nozzles
Version: Avec gicleurs ajustables

Hinweis: DCONMS 30, 40 und 50 werden mit einer Kugelspritzdüse geliefert.
Note: DCONMS 30, 40 and 50 are supplied with a ball spray nozzle.
Observation: Les DCONMS 30, 40 et 50 sont livrés avec une buse de pulvérisation à bille.

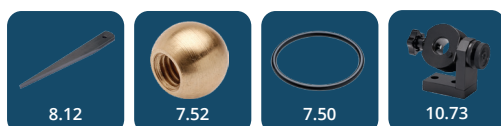



Verwendung:
Zur Aufnahme von Werkzeugen mit Zylinderschaft nach DIN 1835 Form A+B+E und DIN 6535 Form HA+HB+HE (größer Ø 20 mm nur mit Reduzierung).

Application:
For mounting straight-shank tools acc. DIN 1835 form A+B+E and DIN 6535 form HA+HB+HE (larger than Ø 20 mm only with reduction sleeve).

Application:
Pour le serrage d'outils avec queue cylindrique suivant DIN 1835 forme A+B+E et DIN 6535 forme HA+HB+HE (à partir de Ø 20 mm seulement avec réduction).

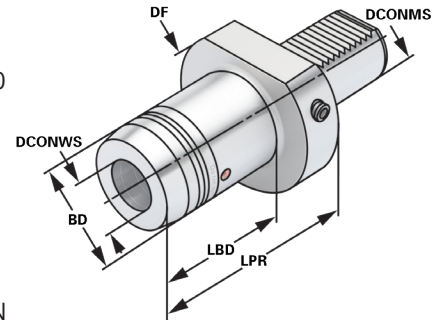

Bestell-Nr. Order no. Référence	Abmessung Size Dimension	DCONMS	DCONWS	BD	LPR	LBD	DF	LSCX	ADJRG
309.H12	30 - 12	30	12	32	54	38	68	47	10
309.H20	30 - 20	30	20	42	89	73	68	52	10
409.H12	40 - 12	40	12	32	60	38	83	47	10
409.H20	40 - 20	40	20	42	95	73	83	52	10

LSCX = Einspannlänge, max. ADJRG = Verstellweg, max.
LSCX = Clamping depth, max. ADJRG = Length adjustment range, max.
LSCX = Profondeur d'insertion, max. ADJRG = Course de réglage, max.

Lieferumfang: Ohne Spanschlüssel
Delivery: Without wrench
Livraison: Sans clé de serrage



Spannkraft-Prüfgerät für Hydrodehnspannfutter - Seite 12.59
Clamping force proofing instrument for hydraulic chucks - page 12.59
Appareil de contrôle des forces de serrage pour mandrin expansibles hydrauliques - page 12.59



Protection steel plugs form Z2

(DIN 69880)

Bouchons de protection en acier forme Z2



Verwendung:
Zum Verschließen der Aufnahmebohrung
am Werkzeugrevolver.

Application:
For sealing the spindle of the turret.

Application:
Pour boucher la broche du tour.

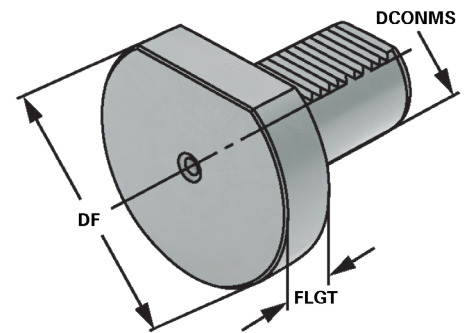
DIN ISO
10889

Z2

Bestell-Nr. Order no. Référence	Abmessung Size Dimension	DCONMS	DF	FLGT
169.29.13	Z2 - 16 × 13	16	40	13
209.29.16	Z2 - 20 × 16	20	50	16
259.29.16	Z2 - 25 × 16	25	58	16
309.29.20	Z2 - 30 × 16	30	68	16
409.29.20	Z2 - 40 × 20	40	83	20
509.29.20	Z2 - 50 × 20	50	98	20





Verwendung:
Zum Verschließen der Aufnahmebohrung
am Werkzeugrevolver.

Application:
For sealing the spindle of the turret.

Application:
Pour boucher la broche du tour.

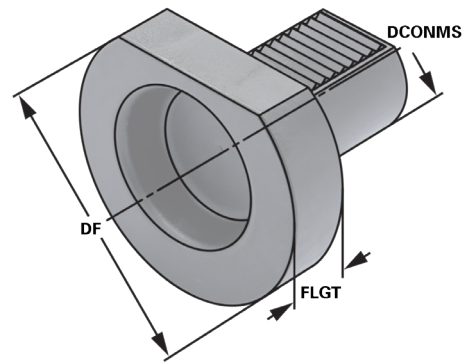
DIN ISO
10889

Z2

Bestell-Nr. Order no. Référence	Abmessung Size Dimension	DCONMS	DF	FLGT
169.30.13	Z2 - 16 × 13	16	40	13
209.30.16	Z2 - 20 × 16	20	50	16
259.30.16	Z2 - 25 × 16	25	58	16
309.30.16	Z2 - 30 × 16	30	68	16
409.30.20	Z2 - 40 × 20	40	83	20
509.30.20	Z2 - 50 × 20	50	98	20





Verwendung:
Zur Aufnahme von Werkzeugen mit Zylinderschaft.

Application:
For mounting tools with straight shank.

Application:
Pour le serrage d'outils avec queue cylindrique.

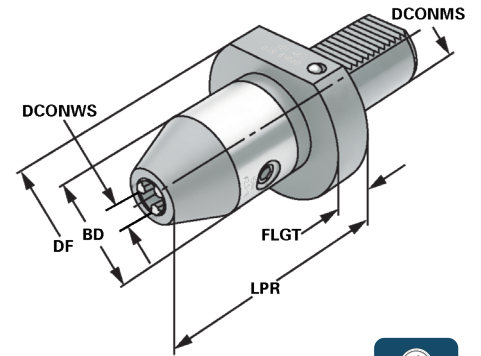

Bestell-Nr. Order no. Référence	DCONMS	DCONWS Spannbereich Capacity Capacité	BD	DF	LPR	FLGT	DRVS
209.15.13	20	1,0 – 13	50	50	90	17	6
309.15.13	30	1,0 – 13	50	68	93	22	6
309.15.16	30	2,5 – 16	50	68	98	22	6
409.15.13	40	1,0 – 13	50	83	93	22	6
409.15.16	40	2,5 – 16	50	83	98	22	6
509.15.13	50	1,0 – 13	50	98	101	30	6
509.15.16	50	2,5 – 16	50	98	106	30	6

Hinweis: Hohe Präzision und Rundlaufgenauigkeit von $\leq 0,03$ mm. Sichere Spannung des Werkzeuges durch mechanische Spannkraftverstärkung. Kein selbständiges Lösen der Spannung während der Bearbeitung bei Links- oder Rechtslauf. Spannen und Lösen mit Sechskantschlüssel.

Note: High precision and accurate concentricity of ≤ 0.03 mm. Secure gripping of the tool through mechanical amplification of the clamping force. No automatic slackening of the clamping force while machining with either clockwise or counter clockwise rotation. Clamping and releasing effected by means of an Allen wrench.

Observation: Précision élevée et exactitude de circularité de $\leq 0,03$ mm. Serrage sûr de l'outil grâce à l'amplification de la force de serrage. Pas de desserrage intempestif en cours d'usinage lors de la rotation la gauche ou la droite. Serrage et desserrage en utilisant un clé sur à fourche.

Lieferumfang: Ohne Spannschlüssel
Delivery: Without wrench
Livraison: Sans clé de serrage



CNC-Drill chucks with coolant supply via spray nozzles
Mandrins de perçage CNC avec arrosage par gicleurs

(DIN 69880)



Verwendung:
Zur Aufnahme von Werkzeugen mit Zylinderschaft.
Application:
For mounting tools with straight shanks.
Application:
Pour le serrage d'outils à queue cylindrique.

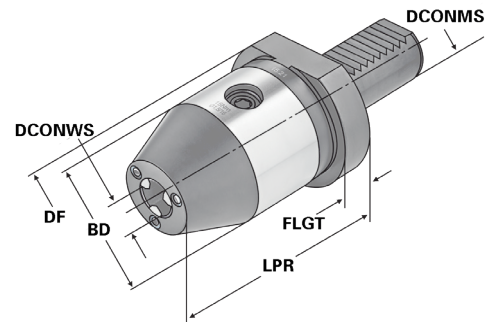

Bestell-Nr. Order no. Référence	DCONMS	DCONWS Spannbereich Capacity Capacité	BD	DF	LPR	FLGT	DRVS
169.15.10.K	16	1,0 – 13	57	40	87	5	6
209.15.10.K	20	1,0 – 13	57	50	87	5	6
259.15.13.K	25	1,0 – 13	57	58	87	15	6
309.15.13.K	30	1,0 – 13	57	68	87	22	6
309.15.16.K	30	2,5 – 16	57	68	92	22	6
409.15.13.K	40	1,0 – 13	57	83	87	22	6
409.15.16.K	40	2,5 – 16	57	83	92	22	6
509.15.13.K	50	1,0 – 13	57	98	92	20	6
509.15.16.K	50	2,5 – 16	57	98	96,9	20	6

Hinweis: Hohe Präzision und Rundlaufgenauigkeit von $\leq 0,03$ mm. Sichere Spannung des Werkzeuges durch mechanische Spannkraftverstärkung. Kein selbständiges Lösen der Spannung während der Bearbeitung bei Links- oder Rechtslauf. Spannen und Lösen mit Sechskantschlüssel.

Note: High precision and accurate concentricity of ≤ 0.03 mm. Secure gripping of the tool through mechanical amplification of the clamping force. No automatic slacking of the clamping force while machining with either clockwise or counter clockwise rotation. Clamping and releasing effected by means of an Allen wrench.

Observation: Précision élevée et exactitude de circularité de $\leq 0,03$ mm. Serrage sûr de l'outil grâce à l'amplification de la force de serrage. Pas de desserrage intempestif en cours d'usinage lors de la rotation la gauche ou la droite. Serrage et desserrage en utilisant un clé sur à fourche.

Lieferumfang: Ohne Spannschlüssel
Delivery: Without wrench
Livraison: Sans clé de serrage



Quick change tapping chucks **with** length compensation on compression and expansion

Mandrins de taraudage à changement rapide **avec** compensation longitudinale à la compression et traction



Verwendung:

Zur Aufnahme von Schnellwechsel-Einsätzen für Gewindebohrer.

Application:

For the chucking of Quick change taps for threading taps.

Application:

Pour le serrage des inserts de changement rapide pour tarauds.

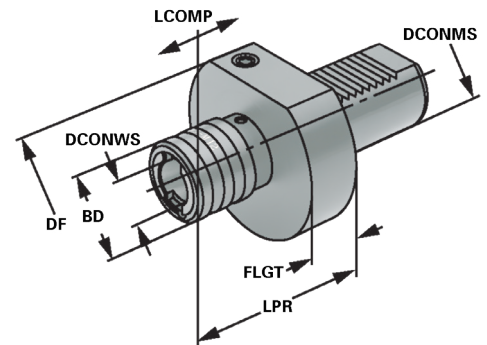

Bestell-Nr. Order no. Référence	DCONMS	Spannbereich Capacity Capacité	SZID	DF	LPR	BD	DCONWS	LCOMP	FLGT
209.16.12	20	M3 – M14	1	50	67	38	19	7	17
259.16.12	25	M3 – M14	1	58	55	38	19	7	18
309.16.12	30	M3 – M14	1	68	58	36	19	7	22
309.16.20	30	M5 – M22	2	68	81	53	31	12	22
409.16.12	40	M3 – M14	1	83	58	36	19	7	22
409.16.20	40	M5 – M22	2	83	81	53	31	12	22
509.16.12	50	M3 – M14	1	98	56	36	19	7	30
509.16.20	50	M5 – M22	2	98	80	53	31	12	30



10.42



10.43



10.48

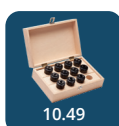

10.49



10.50



7.50

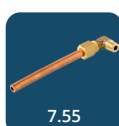

7.55

ohne Längenausgleich auf Druck und Zug

(DIN 69880)

Quick change tapping chucks without length compensation on compression and expansion

Mandrins de taraudage à changement rapide sans compensation longitudinale à la compression et traction



Verwendung:
Für Bearbeitungszentren mit Synchronspindel. Zur Aufnahme von Schnellwechsel-Einsätzen für Gewindebohrer.

Application:
On machining centres with synchronised spindles. For the chucking of Quick change taps for threading taps.

Application:
Sur centres d'usinage avec axe synchrone. Pour le serrage des inserts de changement rapide pour tarauds.

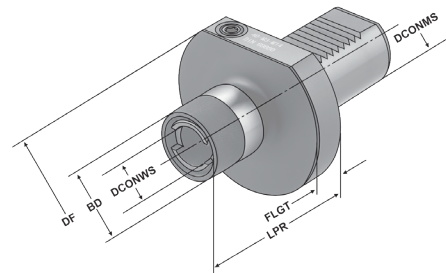

DIN ISO 10889

13.04

Bestell-Nr. Order no. Référence	DCONMS	Spannbereich Capacity Capacité	SZID	DF	LPR	BD	DCONWS	FLGT
309.16.12.1	30	M3 - M14	1	68	55	36	19	22
309.16.20.1	30	M5 - M22	2	68	77	53	31	22
409.16.12.1	40	M3 - M14	1	83	55	36	19	22
409.16.20.1	40	M5 - M22	2	83	77	53	31	22

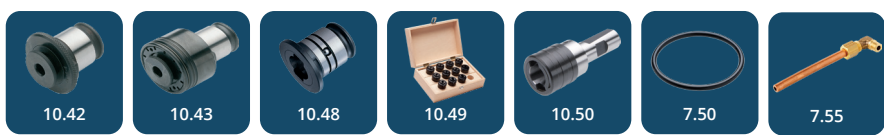

Soft blank fomr A1, rectangular
 Porte-outils ebauche forme A1, rectangle

(DIN 69880)



Verwendung:
 Zur Herstellung von Sonderwerkzeugen.
Application:
 For the manufacturing of special tools.
Application:
 Pour la fabrication d'outils spéciaux.

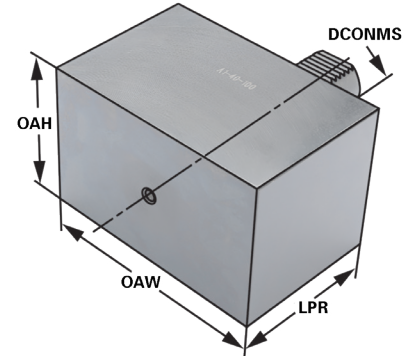

Bestell-Nr. Order no. Référence	Abmessung Size Dimension	DCONMS	LPR	OAH	OAW
169.17.12	A1 - 16 - 78 - 44 - 44	16	44	44	78
209.17.16	A1 - 20 - 100 - 60 - 65	20	65	60	100
259.17.16	A1 - 25 - 100 - 60 - 75	25	75	60	100
309.17.20	A1 - 30 - 130 - 76 - 85	30	85	76	130
409.17.25	A1 - 40 - 151 - 96 - 100	40	100	96	151
509.17.32	A1 - 50 - 160 - 120 - 125	50	125	120	160



Soft blank form A2, round

(DIN 69880)

Porte-outils ebauche forme A2, ronde



Verwendung:
Zur Herstellung von Sonderwerkzeugen.
Application:
For the manufacturing of special tools.
Application:
Pour la fabrication d'outils spéciaux.

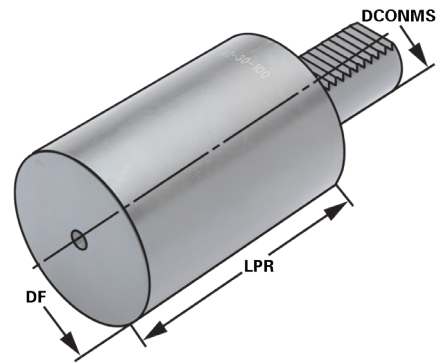

Bestell-Nr. Order no. Référence	Abmessung Size Dimension	DCONMS	DF	LPR
169.19.12	A2 - 16 - 40 - 60	16	40	60
209.19.16	A2 - 20 - 50 - 70	20	50	70
259.19.16	A2 - 25 - 50 - 80	25	58	80
259.19.17	A2 - 25 - 50 - 200	25	58	200
309.19.20	A2 - 30 - 68 - 100	30	68	100
309.19.21	A2 - 30 - 68 - 240	30	68	240
409.19.20	A2 - 40 - 83 - 120	40	83	120
409.19.21	A2 - 40 - 83 - 320	40	83	320
509.19.32	A2 - 50 - 98 - 135	50	98	135
509.19.33	A2 - 50 - 98 - 400	50	98	400





Verwendung:
Zur Abnahme von Werkzeugmaschinen gemäß ISO-Empfehlung R230 oder zur Überprüfung der Werkzeugspindel.

Application:
For the inspection of machine tools according to ISO recommendation R230 or for testing the tool spindle.

Application:
Pour l'inspection de machine-outils suite à la recommandation ISO R230 ou pour la vérification de la broche.

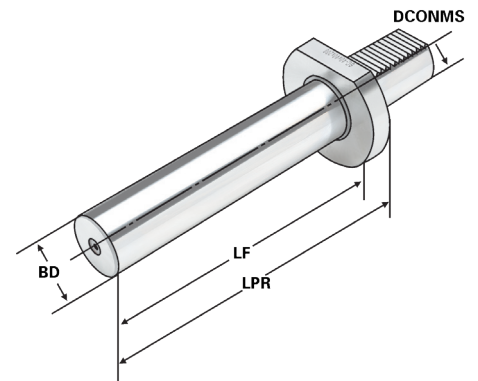

Bestell-Nr. Order no. Référence	Abmessung Size Dimension	DCONMS	BD	LPR	LF
169.18.30	16 - 30 - 120	16	30	120	107
209.18.40	20 - 40 - 150	20	40	150	132
259.18.40	25 - 40 - 150	25	40	150	135
309.18.40	30 - 40 - 200	30	40	230	214
409.18.40	40 - 40 - 200	40	40	200	184
509.18.40	50 - 40 - 200	50	40	200	185

Lieferumfang: Auslieferung mit Prüfprotokoll
Delivery: Delivery with test certificate
Livraison: Livraison avec rapport d'essais

Holzkasten für Kontrolldorne

Wooden box for test arbors
Coffret en bois pour mandrins de contrôle



Verwendung:
Zur Aufbewahrung von Kontrolldornen.

Application:
For the storage of test arbors.

Application:
Pour la conservation de mandrins de contrôle.



Bestell-Nr. Order no. Référence	Abmessung Size Dimension	für Kegelgrößen for cones pour cônes
701.18	460 × 130 × 115	VDI 16 / 20 / 25 / 30 / 40 / 50

Shims
Sous-plaquettes

(DIN 69880)



Verwendung:
Unterlegplatten für VDI Werkzeughalter
Application:
Shims for VDI toolholder
Application:
Assiettes pour porte-outils VDI

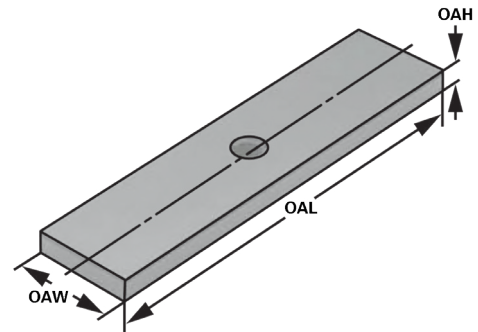

Bestell-Nr. Order no. Référence	OAW	OAH	OAL
209.16.01	14	4	54
259.16.01	13,5	4	49
309.20.01	16	4	69
409.25.01	20	5	84
509.32.01	23	7	99

O-Ringe

O-ring
Joints torique



Verwendung:
O-Ringe zum abdichten des VDI Schaftes
Application:
O-Rings for sealing VDI shanks
Application:
Joints toriques pour étancher des queues VDI

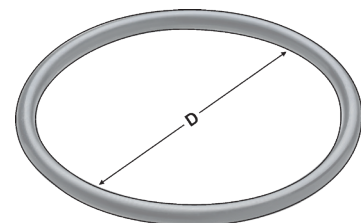

Bestell-Nr. Order no. Référence	D
Z.169.RING	16
Z.209.RING	20
Z.259.RING	25
Z.309.RING	30
Z.409.RING	40
Z.509.RING	50

Plastic ball sprayer nozzles
Gicleurs en plastique

(DIN 69880)

**Verwendung:**

Spritzdüsen für Kühlmittelzufuhr für VDI
Werkzeughalter

Application:

Sprayer nozzles for cooling by VDI toolholders

Application:

Gicleurs pour l'alimentation en refroidissement pour porte-outils VDI

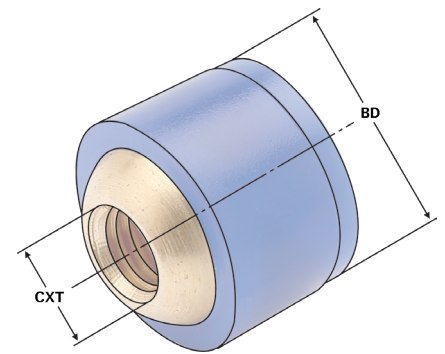

Bestell-Nr. Order no. Référence	BD	CXT
703.08	8	-
703.10	10	M4
703.12	12	M5
703.14	14	M6

Ball sprayer nozzles (brass)
Gicleurs (laiton)

(DIN 69880)



Verwendung:
Spritzdüsen für Kühlmittelzufuhr für VDI Werkzeughalter

Application:
Sprayer nozzles for cooling by VDI toolholders

Application:
Gicleurs pour l'alimentation en refroidissement pour porte-outils VDI

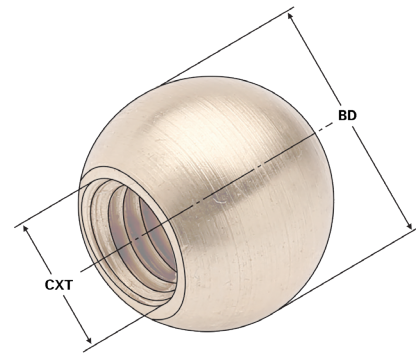

Bestell-Nr. Order no. Référence	BD	CXT	VDI
703.08.ME	8	M5	16
703.10.ME	10	M6	16 + 25 + 30 + 40
703.12.ME	12	M6	50
703.14 .ME	14	M8	-

Kugel mit Düse (Messing)

DIN ISO 10889

Ball sprayer nozzles with coolant tube (brass)

(DIN 69880)

Bille avec gicleur (laiton)



Verwendung:

Spritzdüsen für Kühlmittelzufuhr für VDI
Werkzeughalter

Application:

Sprayer nozzles for cooling by VDI toolholders

Application:

Gicleurs pour l'alimentation en refroidissement pour porte-outils VDI

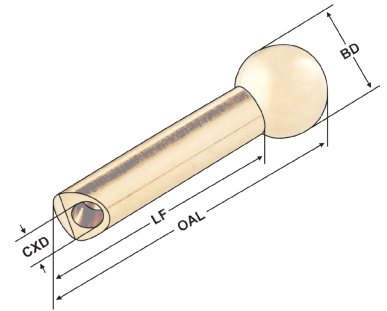

Bestell-Nr. Order no. Référence	BD	OAL	CXD	LF
Z.VDI.100.010	10	35	3	26
Z.VDI.100.012	12	38	4	28
Z.VDI.100.014	14	40	4	28

Kugelspritzdüsen (Messing)

Ball sprayer nozzles (brass)

Gicleurs (laiton)



Verwendung:

Spritzdüsen für Kühlmittelzufuhr für VDI
Werkzeughalter

Application:

Sprayer nozzles for cooling by VDI toolholders

Application:

Gicleurs pour l'alimentation en refroidissement pour porte-outils VDI

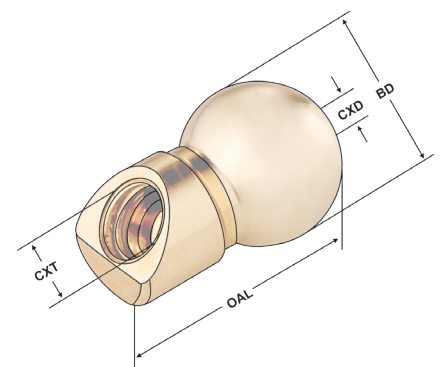

Bestell-Nr. Order no. Référence	BD	OAL	CXD	CXT
Z.VDI.200.010	10	15,8	5	M5
Z.VDI.200.012	12	19	5,5	M6
Z.VDI.200.014	14	19	6	M6



Verwendung:
Spritzdüsen für Kühlmittelzufuhr für VDI
Werkzeughalter

Application:
Sprayer nozzles for cooling by VDI toolholders

Application:
Gicleurs pour l'alimentation en refroidissement pour porte-outils VDI

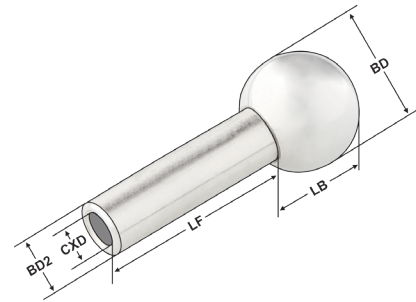

Bestell-Nr. Order no. Référence	BD	LB	LF	BD2	CXD
Z.VDI.300.010	10	8,5	10	6	4
Z.VDI.300.020	10	8,5	20	6	4
Z.VDI.300.040	10	8,5	40	6	4
Z.VDI.310.010	12	10,5	10	6	4
Z.VDI.310.020	12	10,5	20	6	4
Z.VDI.310.040	12	10,5	40	6	4

Material: Edelstahl AISI 304

Material: *Stainless steel AISI 304*

Matériel: Acier inoxydable AISI 304

Einschraub Kühlmittel Düse

Screw-in coolant nozzle
Gicleur a visser



Verwendung:
Spritzdüsen für Kühlmittelzufuhr für VDI
Werkzeughalter

Application:
Sprayer nozzles for cooling by VDI toolholders

Application:
Gicleurs pour l'alimentation en refroidissement pour porte-outils VDI

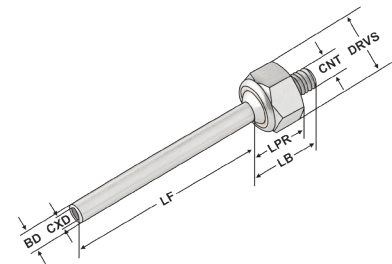

Bestell-Nr. Order no. Référence	CXD	BD	CNT	DRVS	LB	LF	LPR
Z.VDI.400.015	3	5	M5	14	16	15	10
Z.VDI.400.050	3	5	M5	14	16	50	10
Z.VDI.400.100	3	5	M5	14	16	100	10
Z.VDI.410.015	3	5	M6	14	16	15	10
Z.VDI.410.050	3	5	M6	14	16	50	10
Z.VDI.410.100	3	5	M6	14	16	100	10
Z.VDI.420.015	3	5	1/8"	14	16	15	10

Material: Edelstahl AISI 304

Material: *Stainless steel AISI 304*

Matériel: Acier inoxydable AISI 304

Coolant tube (copper)
Canule de lubrification (cuivre)

(DIN 69880)



Verwendung:
Kühlmittelrohr für Kühlmittelzufuhr für VDI Werkzeughalter

Application:
Coolant tube for cooling by VDI toolholders

Application:
Canule de lubrification pour l'alimentation en refroidissement pour porte-outils VDI

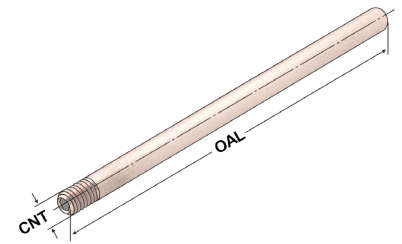

Bestell-Nr. Order no. Référence	OAL	CNT	Ø
Z.VDI.700.200	100	5	Ø 3mm
Z.VDI.700.100	100	6	Ø 3mm

Kühlmittelrohr (Messing) incl. 1/8" Adapter

Coolant tube (brass) incl. 1/8" adapter
Canule de lubrification (laiton) incl. 1/8" adaptateur



Verwendung:
Kühlmittelrohr für Kühlmittelzufuhr für VDI Werkzeughalter

Application:
Coolant tube for cooling by VDI toolholders

Application:
Canule de lubrification pour l'alimentation en refroidissement pour porte-outils VDI

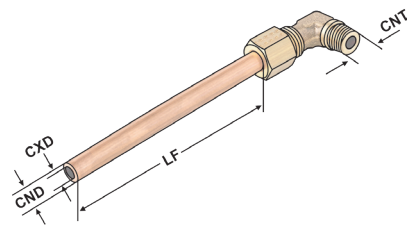

Bestell-Nr. Order no. Référence	CND	CNT	CXD	LF
Z.VDI.K	8	1/8"	4,5	150

Coolant tube
Canule de lubrification

(DIN 69880)



Verwendung:
Kühlmittelrohr für Kühlmittelzufuhr für
VDI Werkzeughalter

Application:
Coolant tube for cooling by VDI toolholders

Application:
Canule de lubrification pour l'alimentation
en refroidissement pour porte-outils VDI

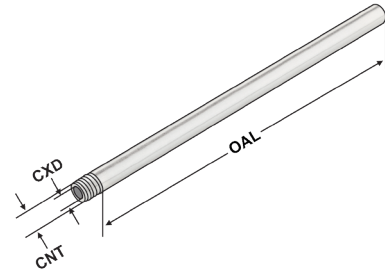

Bestell-Nr. Order no. Référence	CNT	CXD	OAL
Z.VDI.710.015	M4	2	15
Z.VDI.710.100	M4	2	100
Z.VDI.710.200	M4	2	200
Z.VDI.711.015	M5	3	15
Z.VDI.711.100	M5	3	100
Z.VDI.711.200	M5	3	200
Z.VDI.712.015	M6	4	15
Z.VDI.712.100	M6	4	100
Z.VDI.712.200	M6	4	200

Material: Edelstahl AISI 304

Material: *Stainless steel AISI 304*

Matériel: Acier inoxydable AISI 304

für CNC-Drehmaschinen mit HAAS/Doosan BMT-Schnittstelle

Static and power-driven tools for CNC lathes with HAAS/Doosan BMT interface

Porte-outils statiques ou rotatifs pour tours CNC avec HAAS/Doosan interface BMT

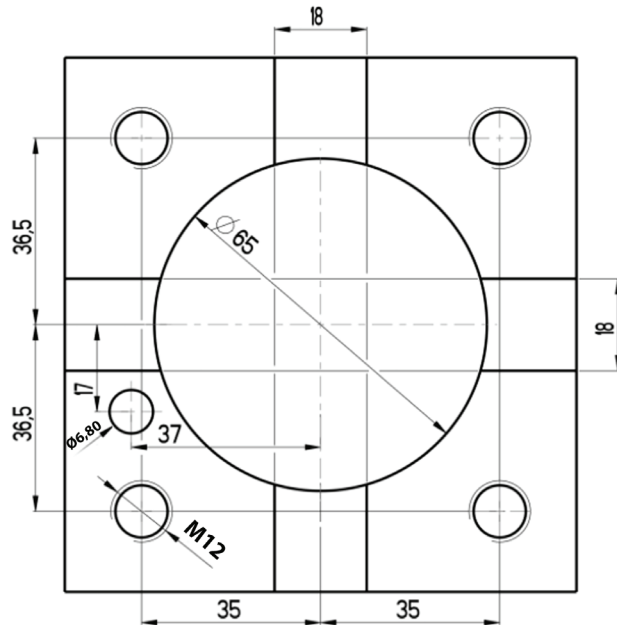

BMT	BMT65
Doosan	PUMA 2100/2600 (M,LM,MS,LMS) PUMA 2100/2600 (Y,LY,SY,LSY) PUMA 300 (M,MS,MB,MC) PUMA 3100 (M,L,M,LY,XLM,XLY,ULM,ULY) PUMA MX2000/2500 PUMA MX2600 (T,ST), PUMA TT2500 (MS/SY) PUMA V400 (M) PUMA VT450 (M,2SP)
Haas	ST 20Y, ST 35Y, DS-30Y
Hwacheon	Cutex-240/HI-TECH200/T2-Series HI-TECH300/400 VT-450
Hyundai	L2100SY SKT-200/250TTSY SKT-250/300 (L,M) SKT-250/300 (MS)
Maxsin	BMT65
SMEC/Samsung	SL 25/SL 35
Tongtai	TMT2000
Victor	Vturn-A26 (YSCM)

ADINTMS (Adapterschnittstelle Maschinenrichtung): BMT driven turret interface -size BT65A

ADINTMS (Adaptive interface machine direction): BMT driven turret interface -size BT65A

ADINTMS (Interface adaptative direction machine): BMT driven turret interface -size BT65A

Index
Sommaire

7.59	7.60	7.61	7.62
			
7.63	7.64	7.65	7.66
			
7.67 - 7.68	7.69 - 7.70	7.71	7.72
			

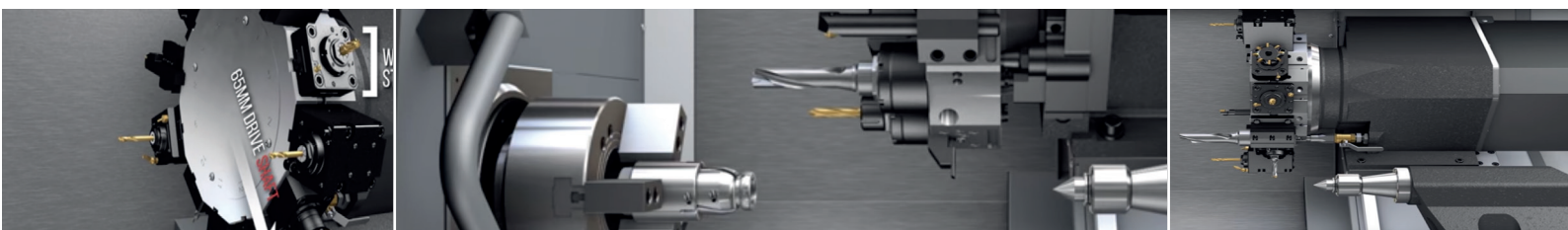

Toolholder with square-longitudinal receptacle doubled

Manche à outils avec porte-outils longitudinal carré double

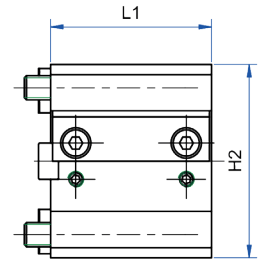
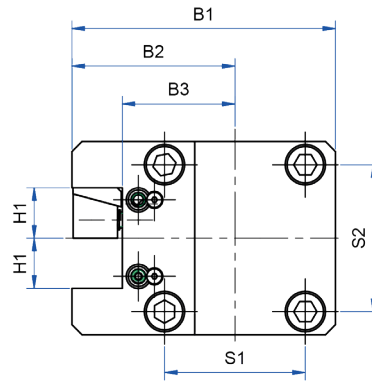
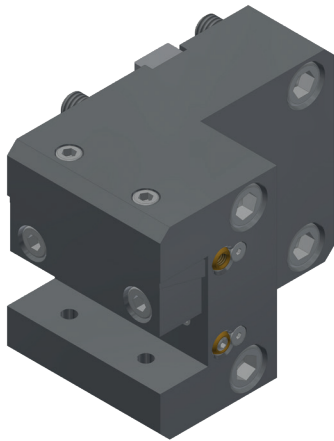

Bestell-Nr. Order no. Référence	H1	H2	B1	B2	B3	L1	S1	S2
AW.102.065.25.755	25	96	131	81	56	80	70	73

BMT	BMT65
Doosan	PUMA 2100/2600 (M,LM,MS,LMS) PUMA 2100/2600 (Y,LY,SY,LSY) PUMA 300 (M,MS,MB,MC) PUMA 3100 (M,LM,LY,XLM,XLY,ULM,ULY) PUMA MX2000/2500 PUMA MX2600 (T,ST), PUMA TT2500 (MS/SY) PUMA V400 (M) PUMA VT450 (M,2SP)
Haas	ST 20Y, ST 35Y, DS-30Y
Hwacheon	Cutex-240/Hi-TECH200/T2-Series Hi-TECH300/400 VT-450
Hyundai	L2100SY SKT-200/250TTSY SKT-250/300 (L,M) SKT-250/300 (MS)
Maxsin	BMT65
SMEC/Samsung	SL 25/SL 35
Tongtai	TMT2000
Victor	Vturn-A26 (YSCM)

Toolholder with square-multi-receptacle

Manche à outils avec porte-outils multiple carré

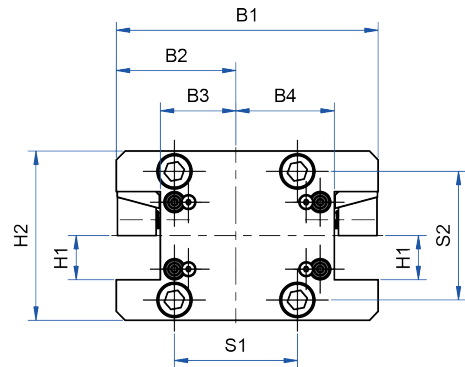
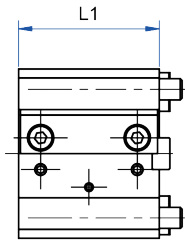
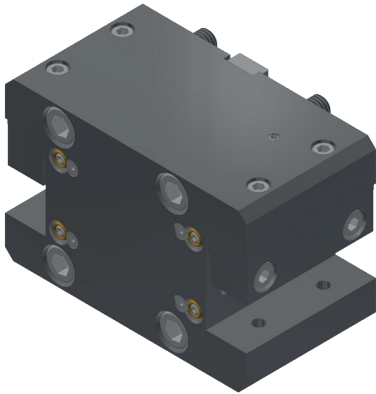

Bestell-Nr. Order no. Référence	H1	H2	B1	B2	B3	B4	L1	S1	S2
AW.103.065.25.755	25	96	149	68	43	56	80	70	73

BMT	BMT65
Doosan	PUMA 2100/2600 (M,LM,MS,LMS) PUMA 2100/2600 (Y,LY,SY,LSY) PUMA 300 (M,MS,MB,MC) PUMA 3100 (M,LM,LY,XLM,XLY,ULM,ULY) PUMA MX2000/2500 PUMA MX2600 (T,ST), PUMA TT2500 (MS/SY) PUMA V400 (M) PUMA VT450 (M,2SP)
Haas	ST 20Y, ST 35Y, DS-30Y
Hwacheon	Cutex-240/Hi-TECH200/T2-Series Hi-TECH300/400 VT-450
Hyundai	L2100SY SKT-200/250TTSY SKT-250/300 (L,M) SKT-250/300 (MS)
Maxsin	BMT65
SMEC/Samsung	SL 25/SL 35
Tongtai	TMT2000
Victor	Vturn-A26 (YSCM)

Toolholder with square-multi-receptacle
 Manche à outils avec porte-outils multiple carré

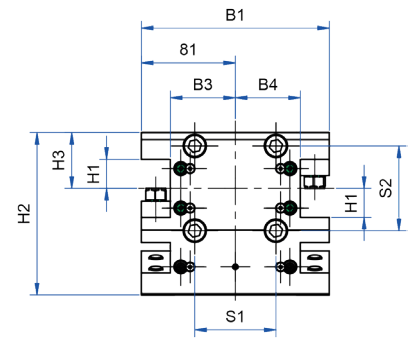
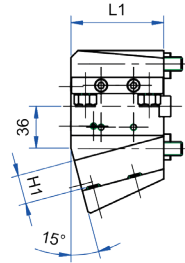
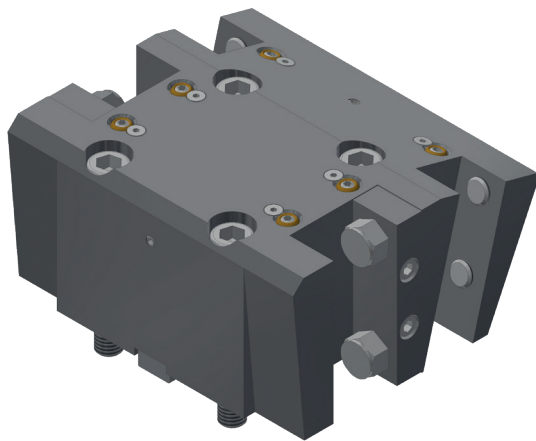

Bestell-Nr. Order no. Référence	H1	H2	H3	B1	B2	B3	B4	L1	S1	S2
AW.103.065.25.756	25	139,873	48	162	81	56	56	80	70	73

BMT	BMT65
Doosan	PUMA 2100/2600 (M,LM,MS,LMS) PUMA 2100/2600 (Y,LY,SY,LSY) PUMA 300 (M,MS,MB,MC) PUMA 3100 (M,LM,LY,XLM,XLY,U,ULM,ULY) PUMA MX2000/2500 PUMA MX2600 (T,ST), PUMA TT2500 (MS/SY) PUMA V400 (M) PUMA VT450 (M,2SP)
Haas	ST 20Y, ST 35Y, DS-30Y
Hwacheon	Cutex-240/Hi-TECH200/T2-Series HI-TECH300/400 VT-450
Hyundai	L2100SY SKT-200/250TTSY SKT-250/300 (L,M) SKT-250/300 (MS)
Maxsin	BMT65
SMEC/Samsung	SL 25/SL 35
Tongtai	TMT2000
Victor	Vturn-A26 (YSCM)

Toolholder with square-multi-receptacle

Manche à outils avec porte-outils multiple carré

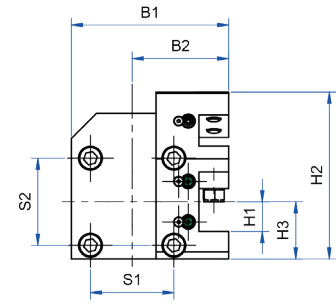
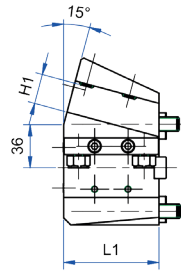
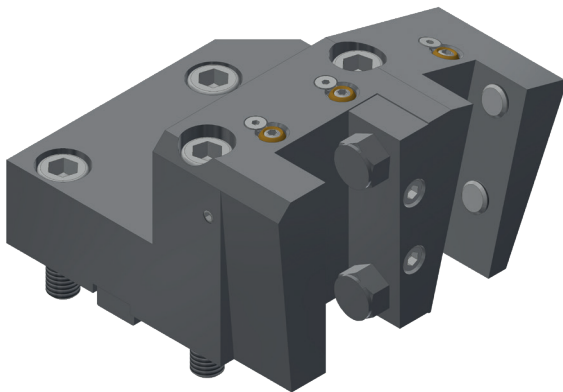

Bestell-Nr. Order no. Référence	H1	H2	H3	B1	B2	L1	S1	S2
AW.103.065.25.753	25	139,873	48	132	81	80	70	73

BMT	BMT65
Doosan	PUMA 2100/2600 (M,LM,MS,LMS) PUMA 2100/2600 (Y,LY,SY,LSY) PUMA 300 (M,MS,MB,MC) PUMA 3100 (M,LM,LY,XLM,XLY,ULM,ULY) PUMA MX2000/2500 PUMA MX2600 (T,ST), PUMA TT2500 (MS/SY) PUMA V400 (M) PUMA VT450 (M,2SP)
Haas	ST 20Y, ST 35Y, DS-30Y
Hwacheon	Cutex-240/Hi-TECH200/T2-Series Hi-TECH300/400 VT-450
Hyundai	L2100SY SKT-200/250TTSY SKT-250/300 (L,M) SKT-250/300 (MS)
Maxsin	BMT65
SMEC/Samsung	SL 25/SL 35
Tongtai	TMT2000
Victor	Vturn-A26 (YSCM)

Front cut-off toolholder

Porte-outils de tronçonnage frontal

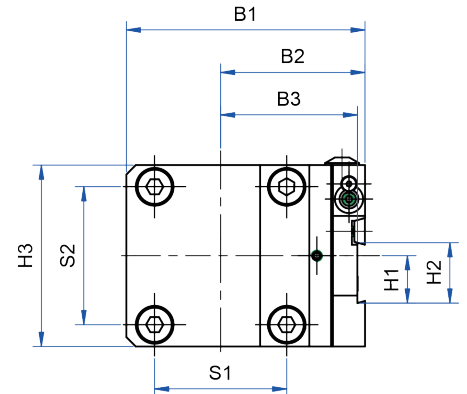
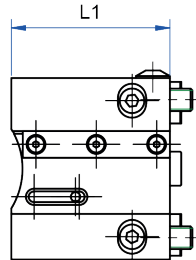
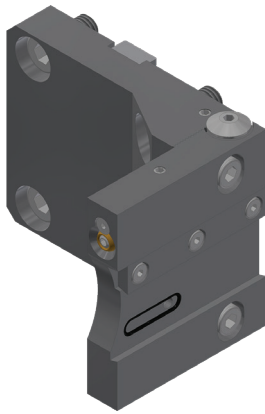

Bestell-Nr. Order no. Référence	H1	H2	H3	B1	B2	B3	L1	S1	S2
AW.105.065.26.753	25	32	96	126,5	76,5	72,5	84	70	73

BMT	BMT65
Doosan	PUMA 2100/2600 (M,LM,MS,LMS) PUMA 2100/2600 (Y,LY,SY,LSY) PUMA 300 (M,MS,MB,MC) PUMA 3100 (M,LM,LY,XLM,XLY,U LM,ULY) PUMA MX2000/2500 PUMA MX2600 (T,ST), PUMA TT2500 (MS/SY) PUMA V400 (M) PUMA VT450 (M,2SP)
Haas	ST 20Y, ST 35Y, DS-30Y
Hwacheon	Cutex-240/Hi-TECH200/T2-Series Hi-TECH300/400 VT-450
Hyundai	L2100SY SKT-200/250TTSY SKT-250/300 (L,M) SKT-250/300 (MS)
Maxsin	BMT65
SMEC/Samsung	SL 25/SL 35
Tongtai	TMT2000
Victor	Vturn-A26 (YSCM)

Cylindrical shank receptacle
Support de tige cylindrique

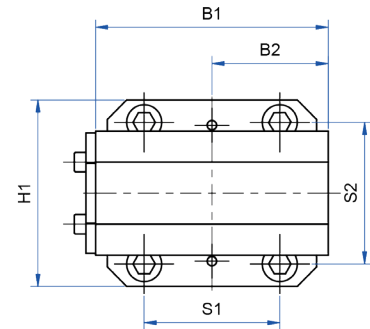
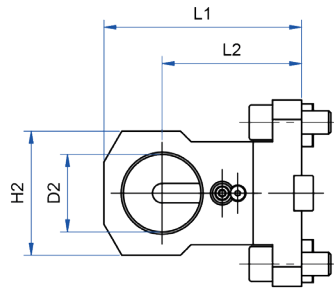
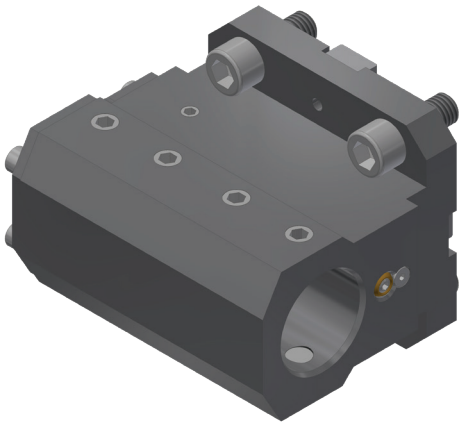

Bestell-Nr. Order no. Référence	D2	H1	H2	B1	B2	L1	L2	S1	S2
AW.107.265.40.750	40	96	64	120	60	102	72	70	73

BMT	BMT65
Doosan	PUMA 2100/2600 (M,LM,MS,LMS) PUMA 2100/2600 (Y,LY,SY,LSY) PUMA 300 (M,MS,MB,MC) PUMA 3100 (M,LM,LY,XLM,XLY,ULM,ULY) PUMA MX2000/2500 PUMA MX2600 (T,ST), PUMA TT2500 (MS/SY) PUMA V400 (M) PUMA VT450 (M,2SP)
Haas	ST 20Y, ST 35Y, DS-30Y
Hwacheon	Cutex-240/Hi-TECH200/T2-Series Hi-TECH300/400 VT-450
Hyundai	L2100SY SKT-200/250TTSY SKT-250/300 (L,M) SKT-250/300 (MS)
Maxsin	BMT65
SMEC/Samsung	SL 25/SL 35
Tongtai	TMT2000
Victor	Vturn-A26 (YSCM)



Cylindrical shank receptacle
Support de tige cylindrique

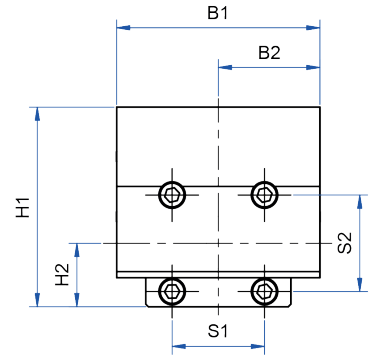
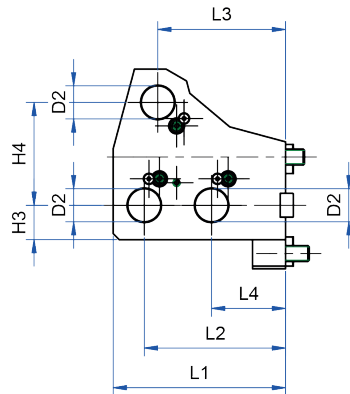
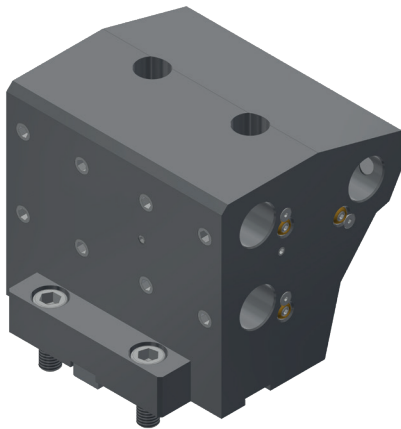

Bestell-Nr. Order no. Référence	D2	H1	H2	H3	H4	B1	B2	L1	L2	L3	L4	S1	S2
AW.107.265.25.756	25	151	48	26	77,82	154	77	130,5	107	96,755	56	70	73

BMT	BMT65
Doosan	PUMA 2100/2600 (M,LM,MS,LMS) PUMA 2100/2600 (Y,LY,SY,LSY) PUMA 300 (M,MS,MB,MC) PUMA 3100 (M,LM,LY,XLM,XLY,ULM,ULY) PUMA MX2000/2500 PUMA MX2600 (T,ST), PUMA TT2500 (MS/SY) PUMA V400 (M) PUMA VT450 (M,2SP)
Haas	ST 20Y, ST 35Y, DS-30Y
Hwacheon	Cutex-240/Hi-TECH200/T2-Series Hi-TECH300/400 VT-450
Hyundai	L2100SY SKT-200/250TTSY SKT-250/300 (L,M) SKT-250/300 (MS)
Maxsin	BMT65
SMEC/Samsung	SL 25/SL 35
Tongtai	TMT2000
Victor	Vturn-A26 (YSCM)



Cylindrical shank receptacle
Support de tige cylindrique

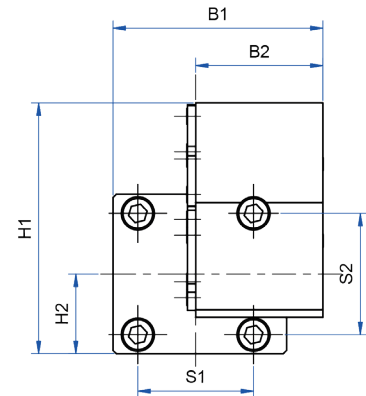
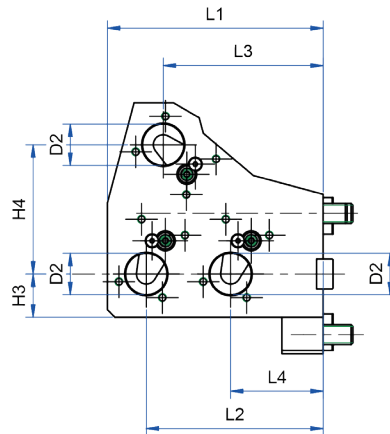
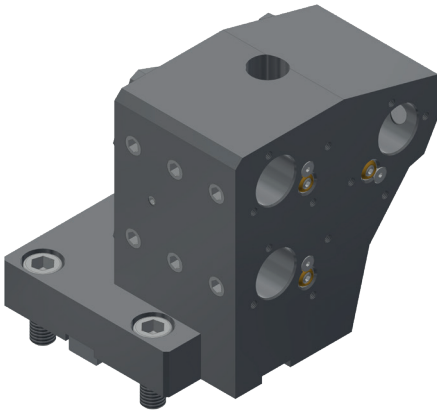

Bestell-Nr. Order no. Référence	D2	H1	H2	H3	H4	B1	B2	L1	L2	L3	L4	S1	S2
AW.107.265.25.753	25	151	48	26	77,82	127	77	130,5	107	96,755	56	70	73

BMT	BMT65
Doosan	PUMA 2100/2600 (M,LM,MS,LMS) PUMA 2100/2600 (Y,LY,SY,LSY) PUMA 300 (M,MS,MB,MC) PUMA 3100 (M,LM,LY,XLM,XLY,ULM,ULY) PUMA MX2000/2500 PUMA MX2600 (T,ST), PUMA TT2500 (MS/SY) PUMA V400 (M) PUMA VT450 (M,2SP)
Haas	ST 20Y, ST 35Y, DS-30Y
Hwacheon	Cutex-240/HI-TECH200/T2-Series HI-TECH300/400 VT-450
Hyundai	L2100SY SKT-200/250TTSY SKT-250/300 (L,M) SKT-250/300 (MS)
Maxsin	BMT65
SMEC/Samsung	SL 25/SL 35
Tongtai	TMT2000
Victor	Vturn-A26 (YSCM)



Axial drilling and milling head for external cooling

Tête d'alésage et de fraisage axiale pour refroidissement externe

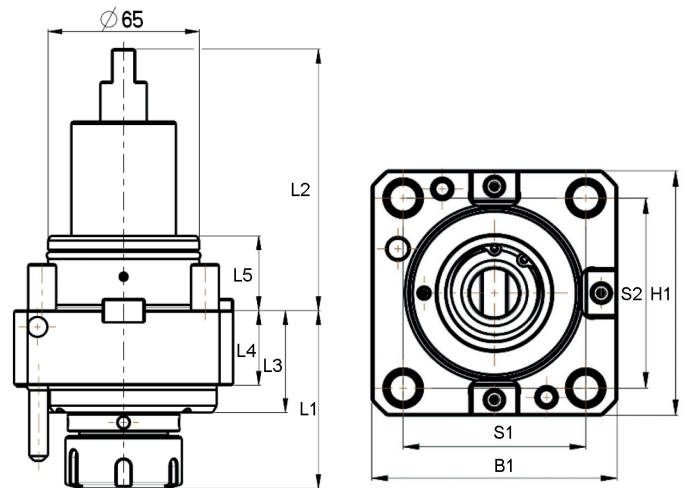
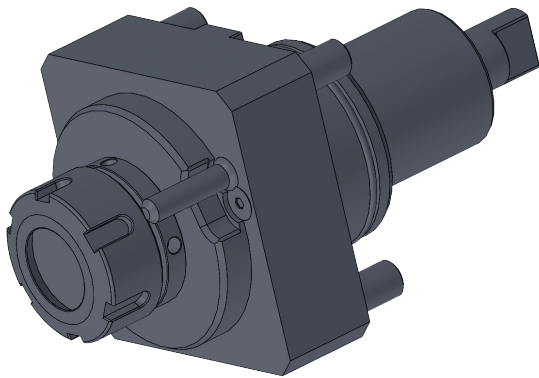

Bestell-Nr. Order no. Référence	B1	H1	S1	S2	L1	L2	L3	L4	L5	n max. min-1	T max. Nm
AW.221.065.20.751	94	94	70	73	76,3	112	43,7	32	32	6000	70

Typ: 470E | ER 32
 DCONWS: 3 - 20
 CP: 20 bar

BMT	BMT65
Doosan	PUMA 2100/2600 (M,LM,MS,LMS) PUMA 2100/2600 (Y,LY,SY,LSY) PUMA 300 (M,MS,MB,MC) PUMA 3100 (M,LM,LY,XLM,XLY,ULM,ULY) PUMA MX2000/2500 PUMA MX2600 (T,ST), PUMA TT2500 (MS/SY) PUMA V400 (M) PUMA VT450 (M,2SP)
Haas	ST 20Y, ST 35Y, DS-30Y
Hwacheon	Cutex-240/Hi-TECH200/T2-Series HI-TECH300/400 VT-450
Hyundai	L2100SY SKT-200/250TTSY SKT-250/300 (L,M) SKT-250/300 (MS)
Maxsin	BMT65
SMEC/Samsung	SL 25/SL 35
Tongtai	TMT2000
Victor	Vturn-A26 (YSCM)



Axial drilling and milling head for internal and external cooling

Tête d'alésage et de fraisage axiale pour refroidissement interne et externe

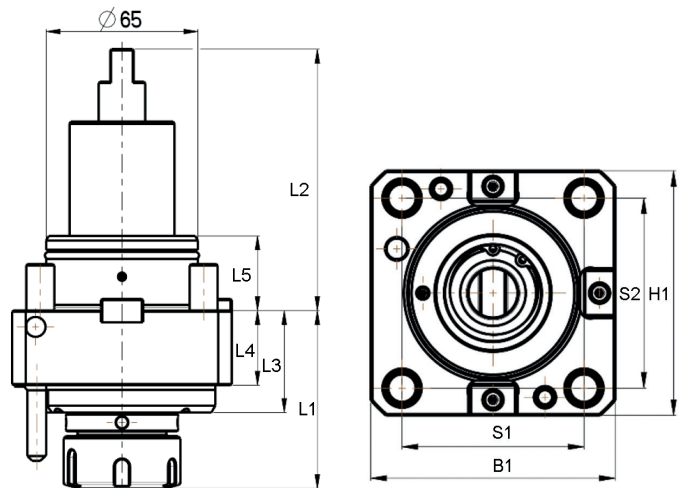
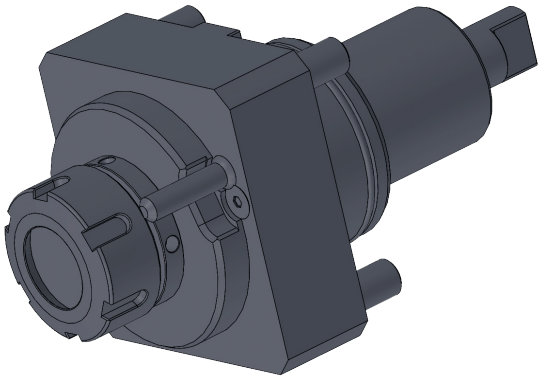

Bestell-Nr. Order no. Référence	B1	H1	S1	S2	L1	L2	L3	L4	L5	n max. min-1	T max. Nm
AW.221.065.20.756	94	94	70	73	76,3	112	43,7	32	32	6000	70

Typ: 470E | ER 32
 DCONWS: 3 - 20
 CP: 20 bar

BMT	BMT65
Doosan	PUMA 2100/2600 (M,LM,MS,LMS) PUMA 2100/2600 (Y,LY,SY,LSY) PUMA 300 (M,MS,MB,MC) PUMA 3100 (M,LM,LY,XLM,XLY,ULM,ULY) PUMA MX2000/2500 PUMA MX2600 (T,ST), PUMA TT2500 (MS/SY) PUMA V400 (M) PUMA VT450 (M,2SP)
Haas	ST 20Y, ST 35Y, DS-30Y
Hwacheon	Cutex-240/HI-TECH200/T2-Series HI-TECH300/400 VT-450
Hyundai	L2100SY SKT-200/250TTSY SKT-250/300 (L,M) SKT-250/300 (MS)
Maxsin	BMT65
SMEC/Samsung	SL 25/SL 35
Tongtai	TMT2000
Victor	Vturn-A26 (YSCM)



Radial drilling and milling head for external cooling

Tête d'alésage et de fraisage radiale pour refroidissement externe

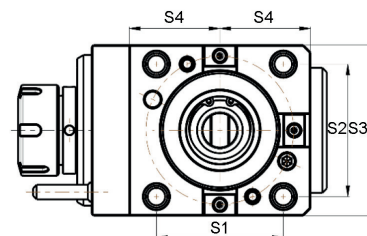
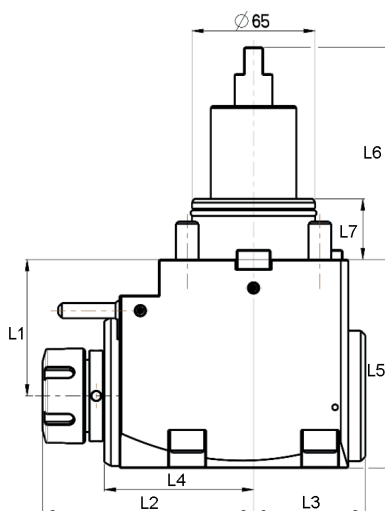
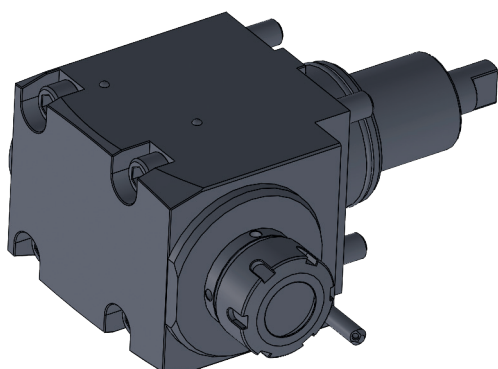

Bestell-Nr. Order no. Référence	S1	S2	S3	S4	L1	L2	L3	L4	L5	L6	L7	n max. min-1	T max. Nm
AW.221.265.20.751	70	73	94	50	72	111,3	59	78,7	110	112	32	6000	70

Typ: 470E | ER 32
 DCONWS: 3 - 20
 CP: 20 bar

BMT	BMT65
Doosan	PUMA 2100/2600 (M,LM,MS,LMS) PUMA 2100/2600 (Y,LY,SY,LSY) PUMA 300 (M,MS,MB,MC) PUMA 3100 (M,LM,LY,XLM,XLY,ULM,ULY) PUMA MX2000/2500 PUMA MX2600 (T,ST), PUMA TT2500 (MS/SY) PUMA V400 (M) PUMA VT450 (M,2SP)
Haas	ST 20Y, ST 35Y, DS-30Y
Hwacheon	Cutex-240/HI-TECH200/T2-Series HI-TECH300/400 VT-450
Hyundai	L2100SY SKT-200/250TTSY SKT-250/300 (L,M) SKT-250/300 (MS)
Maxsin	BMT65
SMEC/Samsung	SL 25/SL 35
Tongtai	TMT2000
Victor	Vturn-A26 (YSCM)



Axial drilling and milling head for internal and external cooling

Tête d'alésage et de fraise axiale pour refroidissement interne et externe

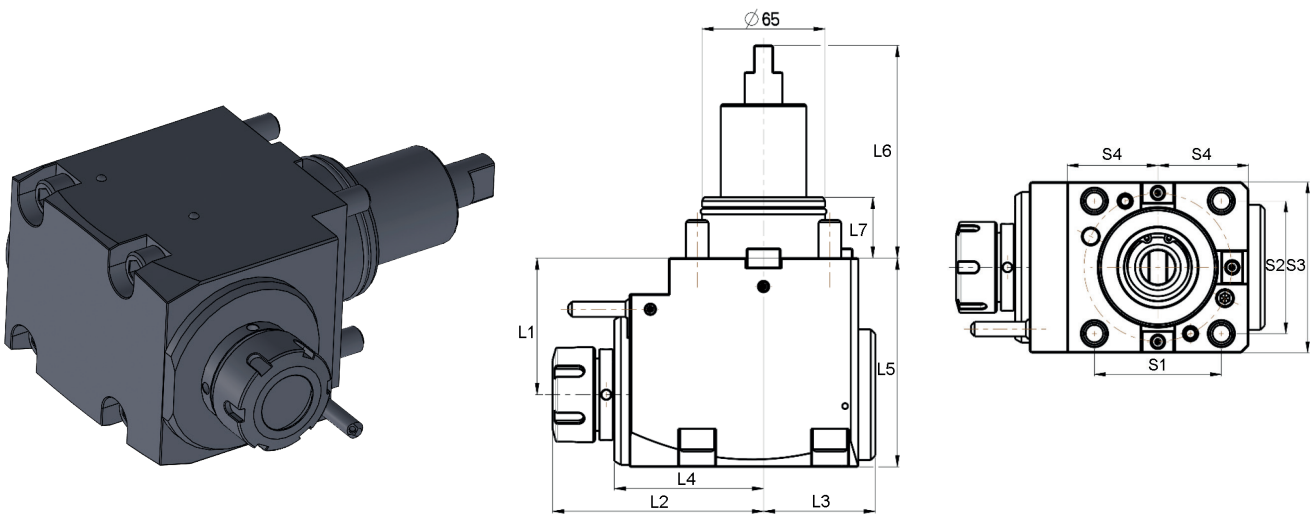

Bestell-Nr. Order no. Référence	S1	S2	S3	S4	L1	L2	L3	L4	L5	L6	L7	n max. min-1	T max. Nm
AW.221.265.20.756	70	73	94	50	72	111,3	59	78,7	110	112	32	6000	70

Typ: 470E | ER 32
 DCONWS: 3 - 20
 CP: 20 bar

BMT	BMT65
Doosan	PUMA 2100/2600 (M,LM,MS,LMS) PUMA 2100/2600 (Y,LY,SY,LSY) PUMA 300 (M,MS,MB,MC) PUMA 3100 (M,LM,LY,XLM,XLY,ULM,ULY) PUMA MX2000/2500 PUMA MX2600 (T,ST), PUMA TT2500 (MS/SY) PUMA V400 (M) PUMA VT450 (M,2SP)
Haas	ST 20Y, ST 35Y, DS-30Y
Hwacheon	Cutex-240/Hi-TECH200/T2-Series HI-TECH300/400 VT-450
Hyundai	L2100SY SKT-200/250TTSY SKT-250/300 (L,M) SKT-250/300 (MS)
Maxsin	BMT65
SMEC/Samsung	SL 25/SL 35
Tongtai	TMT2000
Victor	Vturn-A26 (YSCM)



ISO 15488 (DIN 6499) System ER

Collet chucks with straight shank with with clamping surface for collets ISO 15488 (DIN 6499) ER-system
Mandrins à pinces à queue cylindrique avec surface de serrage pour pinces ISO 15488 (DIN 6499) système ER



Verwendung:
Zur Aufnahme von Werkzeugen mit Zylinderschaft in Spannzangen.
Application:
For mounting straight-shank tools in collets.
Application:
Pour le serrage d'outils avec queue cylindrique dans des pinces de serrage.

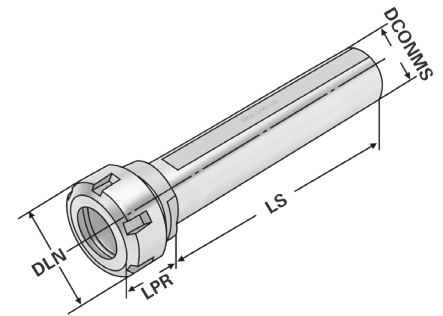

Bestell-Nr. Order no. Référence	DCONMS	DCONWS Spannbereich Capacity Capacité	Typ	LS	LPR	DLN	DRVS	CND	THID
120.02.04.10	16	1 – 10	426E ER 16	150	30	32	19	9	M10 x 1,5
120.02.04.16	20	1 – 16	430E ER 25	150	40	42	27	11	M12 x 1,5
120.02.04.20	32	2 – 20	470E ER 32	150	35	50	32	19	M20 x 1,5
120.02.04.20.1	40	2 – 20	470E ER 32	120	35	50	36	19	M20 x 1,5

Durchgangsbohrung für Innenkühlung vorhanden.
Through hole for internal cooling provided.
Trou débouchant disponible pour arrosage interne.

Lieferumfang: Inkl. Spannmutter
Delivery: Clamping nuts
Livraison: Ecrou de serrage

Spannfutter mit Zylinderschaft für Spannzangen

ISO 15488 (DIN 6499) System ER

Collet chucks with straight shank for collets ISO 15488 (DIN 6499) ER-system
Mandrins à pinces à queue cylindrique pour pinces ISO 15488 (DIN 6499) système ER



Verwendung:
Zur Aufnahme von Werkzeugen mit Zylinderschaft in Spannzangen.
Application:
For mounting straight-shank tools in collets.
Application:
Pour le serrage d'outils avec queue cylindrique dans des pinces de serrage.

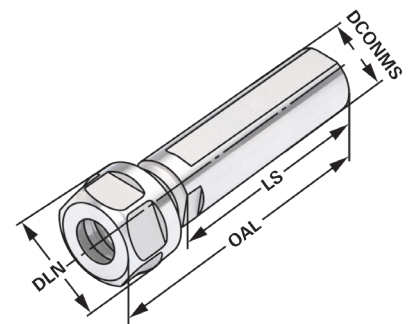

Bestell-Nr. Order no. Référence	DCONMS	DCONWS Spannbereich Capacity Capacité	Typ	DLN	LS	OAL	DRVS	CND	THID
120.02.A.07	20	1 – 07	4008E ER 11	19	50	67,5	17	7	-
120.02.A.07.1	20	1 – 07	4008E ER 11	19	70	87,5	17	7	-
120.02.A.10	20	1 – 10	426E ER 16	28	70	96,0	17	10	7/16" 20 UNF
120.02.A.13	25	1 – 13	428E ER 20	34	50	74,0	22	13	9/16" 18 UNF

Sechskantmutter
Hexagonal clamping nut
Écrous hexagonal

Durchgangsbohrung für Innenkühlung vorhanden.
Through hole for internal cooling provided.
Trou débouchant disponible pour arrosage interne.

Hook wrench with pin 45-50 | ER32 | 2-20 |

Clé à ergot rond 45-50 | ER32 | 2-20 |



Bestell-Nr. Order no. Référence	Spannbereich Capacity Capacité
AW.SE4550	45 – 50 (ER 32)

Spannschlüssel für Spannmuttern System ER

Wrenches for clamping nuts ER-system

Clés de serrage pour écrous de serrage système ER



Bestell-Nr. Order no. Référence	Spannbereich Capacity Capacité
02.20	2 – 20 (ER 32)