

**WERKZEUGAUFNAHMEN
ISO 12164 & DIN 69893 (HSK)**

**TOOLHOLDERS
ISO 12164 & DIN 69893 (HSK)**

**PORTE-OUTILS
ISO 12164 & DIN 69893 (HSK)**

ISO 12164 - HSK

DIN 69893 - HSK

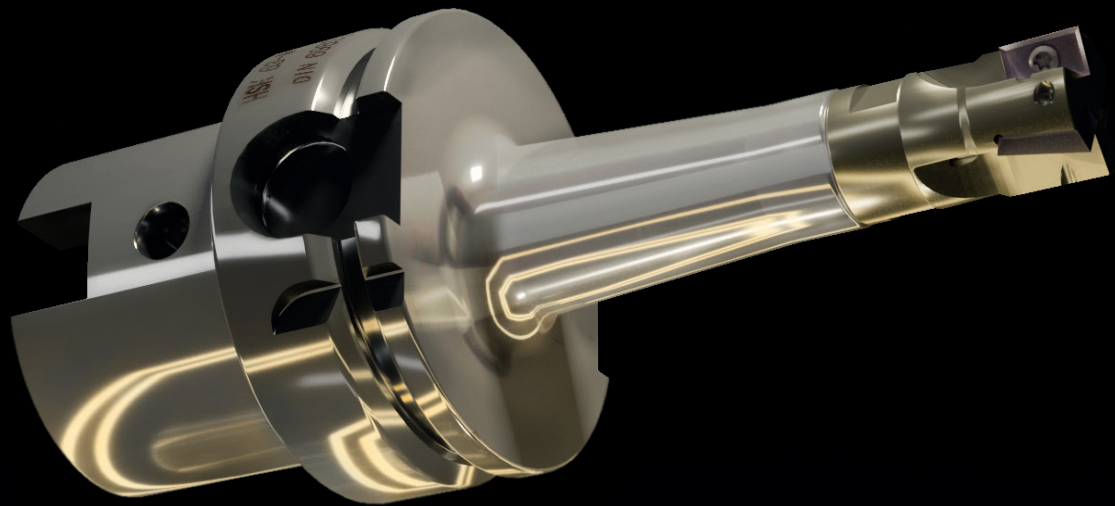

Toolholders ISO 12164-1 (formerly DIN 69893) - HSK
 Porte-outils ISO 12164-1 (l'ancien DIN 69893) - HSK

(DIN 69893-1 | HSK-A)

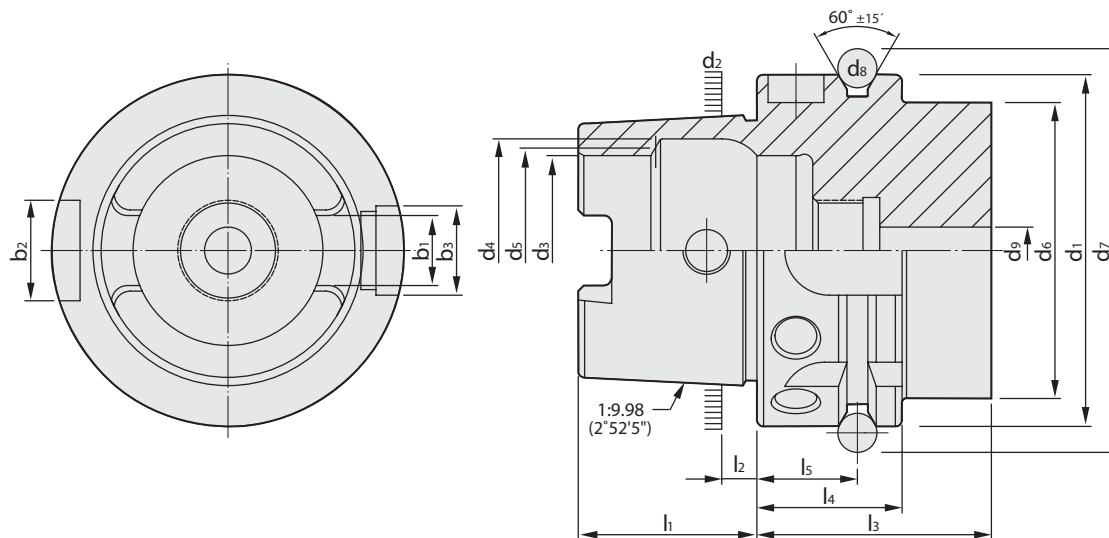

HSK	d ₁	d ₂	d ₃	d ₄	d ₅	d ₆	d ₇	d ₈	d ₉	l ₁	l ₂	l ₃	l ₄	l ₅	b ₁	b ₂	b ₃
	h10		H10	H11		max	⁰ _{-0,1}		max	⁰ _{-0,2}		min	⁰ _{-0,1}	±0,1	±0,04	H10	H10
25	25	19,006	14	16,4	15	20	28,5	3	3	13	2,5	20	10	4,5	6,05	6	7
32	32	24,007	17	20,5	19	26	37	4	4,2	16	3,2	35	20	16	7,05	7	9
40	40	30,007	21	25,5	23	34	45	4	5	20	4	35	20	16	8,05	9	11
50	50	38,009	26	32	29	42	59,3	7	6,8	25	5	42	26	18	10,54	12	14
63	63	48,010	34	40	37	53	72,3	7	8,4	32	6,3	42	26	18	12,54	16	18
80	80	60,012	42	50	46	68	88,8	7	10,2	40	8	42	26	18	16,04	18	20
100	100	75,013	53	63	58	88	109,75	7	12	50	10	45	29	20	20,02	20	22
125	125	95,016	67	80	73	111	134,75	7	14	63	12,5	45	29	20	25,02	25	28

Vorgewuchtet G 6,3 15.000 min-1
Pre-balanced G 6,3 15.000 min-1
 Pré-équilibré G 6,3 15.000 min-1

G 2,5 Feinwuchten gegen Aufpreis
G 2.5 Fine balancing at extra charge
 G 2,5 Equilibrage fin contre un supplément

Werkstoff: Legierter Einsatzstahl mit einer Zugfestigkeit im Kern von min. 950 N / mm².
 Einsatzgehärtet HRC 60 ± 2 (HV 700 ± 50), Härtetiefe 0,8 mm ± 0,2 mm,
 brüniert und präzisionsgeschliffen.

Material: Alloyed case-hardened steel, tensile core strength of min. 950 N / mm².
 Case hardened HRC 60 ± 2 (HV 700 ± 50), hardening depth 0.8 mm ± 0.2 mm,
 black-finished and precisely grinded.

Matière: Acier de cémentation allié. Résistance à la traction dans le noyau
 de min 950 N / mm².
 Cémentation à HRC 60 ± 2 (HV 700 ± 50), profondeur de cémentation
 0,8 mm ± 0,2 mm, bruni et rectifié précisément.

Normative Verweise:

ISO 12164-1:2001-12
 Hohlkegelschnittstelle mit Plananlage
 - Teil 1: Schäfte; Maße

DIN 69893-1:2011
 Kegel-Hohlschäfte mit Plananlage besteht aus:
 - Teil 1: Kegel-Hohlschäfte Form A und Form C;
 Maße und Ausführung

Normative references:

ISO 12164-1:2001
 Hollow taper interface with flange contact surface
 - Part 1: Shanks; Dimensions

DIN 69893-1:2011
 Hollow taper shanks with flange contact surface:
 - Part 1: Hollow taper shanks type A and type C;
 Dimensions and design

Références normatives:

ISO 12164-1:2001
 Interfaces à cône creux-face
 - Partie 1: Queues; Dimensions

DIN 69893-1:2011
 Queues creuses coniques à surface de contact plane:
 - Partie 1: Queues creuses coniques type A et type C;
 Dimensions et conception

Index
Sommaire

(DIN 69893-1 | HSK-A)

5.05	5.06	5.07	5.09
			
5.10	5.11	5.13	5.16
			
5.19	5.20	5.21	5.23
			
5.24	5.25	5.26	5.27
			
5.28	5.29	5.30	5.31
			
5.32	5.33	5.37	5.44
			
5.46	5.47	5.48	5.49-5.50
			
5.51	5.67	5.83	
HSK-C 	HSK-E 	HSK-F 	

Collet chucks for collets ISO 10897 (DIN 6388) OZ-system
Mandrins à pinces pour pinces ISO 10897 (DIN 6388) système OZ

(DIN 69893-1 | HSK-A)



Verwendung:
Zur Aufnahme von Werkzeugen mit Zylinderschaft in Spannzangen.

Application:
For mounting straight-shank tools in collets.

Application:
Destiné à recevoir les outils avec les queues de forme cylindrique dans les pinces de serrage.

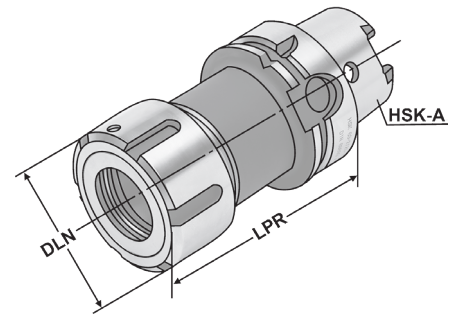

Bestell-Nr. Order no. Référence	HSK	DCONWS Spannbereich Capacity Capacité	Typ	LPR	DLN	THID
A50.01.16	HSK-A 50	2 - 16	415E OZ 16	90	43	M16 x 2,0
A50.01.25	HSK-A 50	2 - 25	462E OZ 25	110	60	M16 x 2,0
A63.01.16	HSK-A 63	2 - 16	415E OZ 16	100	43	M16 x 2,0
A63.01.25	HSK-A 63	2 - 25	462E OZ 25	100	60	M16 x 2,0
A63.01.32	HSK-A 63	3 - 32	467E OZ 32	120	72	M16 x 2,0
A100.01.16	HSK-A 100	2 - 16	415E OZ 16	110	43	M16 x 2,0
A100.01.25	HSK-A 100	2 - 25	462E OZ 25	120	60	M16 x 2,0
A100.01.32	HSK-A 100	3 - 32	467E OZ 32	130	72	M16 x 2,0

Lieferumfang: Mit kugelgelagerter Spannmutter
Delivery: With ball bearing clamping nut
Livraison: Avec écrou de serrage à roulement à billes



Collet chucks for collets | KPS-system

(DIN 69893-1 | HSK-A)

Mandrins à pinces pour pinces | Système KPS

**Verwendung:**

Zur Aufnahme von Werkzeugen mit Zylinderschaft in Spannzangen.
Für Anwendungen im HSC-Bereich und für hochpräzise Bearbeitungsergebnisse.

Application:

For mounting straight-shank tools in collets.
To use for high speed cutting and high precision milling.

Utilisation:

Pour la fixation d'outils à queue cylindrique dans les pinces de serrage. Pour l'UGV (Usinage à Grande Vitesse) et pour des résultats d'usinage de haute précision.

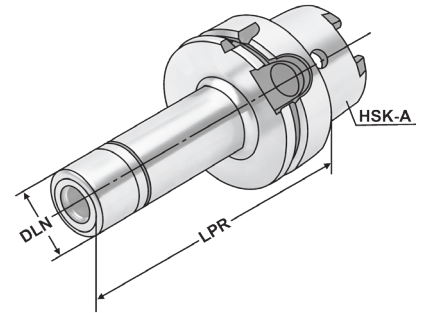

Bestell-Nr. Order no. Référence	HSK	DCONWS Spannbereich Capacity Capacité	Typ	LPR	DLN	THID
A40.03.10	HSK-A 40	1 - 10	490EK KPS 10	75	27,5	M12 x 1,75
A40.03.16	HSK-A 40	4 - 16	496EK KPS 16	80	40,0	M18 x 1,50
A50.03.10	HSK-A 50	1 - 10	490EK KPS 10	60	27,5	M12 x 1,75
A50.03.16	HSK-A 50	4 - 16	496EK KPS 16	80	40,0	M18 x 1,50
A63.03.10	HSK-A 63	1 - 10	490EK KPS 10	100	27,5	M12 x 1,75
A63.03.10.2	HSK-A 63	1 - 10	490EK KPS 10	160	27,5	M12 x 1,75
A63.03.16	HSK-A 63	4 - 16	496EK KPS 16	120	40,0	M18 x 1,50
A63.03.16.2	HSK-A 63	4 - 16	496EK KPS 16	160	40,0	M18 x 1,50

Lieferumfang: Mit gewuchteter Spannmutter
Delivery: With balanced clamping nut
Livraison: Avec écrou de serrage équilibré

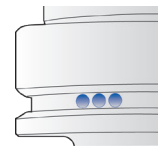
Gewuchtete Ausführung**Balanced type
Type équilibré**

Bestell-Nr. Order no. Référence	Abmessung Size Dimension
---------------------------------------	--------------------------------

**Wuchten auf G 2,5 von vorgewuchteten
Kemmler-Werkzeugen**

Balancing at G 2.5 of pre-balanced Kemmler-tools
Équilibrage sur G 2,5 d'outils Kemmler pré-équilibrés

W25

Ohne Wuchtprotokoll

Without balancing report
Sans protocole d'équilibrage

W25.2

Mit Wuchtprotokoll

With balancing report
Avec protocole d'équilibrage

**Wuchten von nicht vorgewuchteten Werkzeugen
Balancing of unbalanced tools
Équilibrage d'outils non-équilibrés**

W25.1

Ohne Wuchtprotokoll

Without balancing report
Sans protocole d'équilibrage



Collet chucks for collets ISO 15488 (DIN 6499) ER-system

(DIN 69893-1 | HSK-A)

Mandrins à pinces pour pinces ISO 15488 (DIN 6499) système ER

**Verwendung:**

Zur Aufnahme von Werkzeugen mit Zylinderschaft in Spannzangen.

Application:

For mounting straight-shank tools in collets.

Application:

Destiné à recevoir les outils avec les queues de forme cylindrique dans les pinces de serrage.

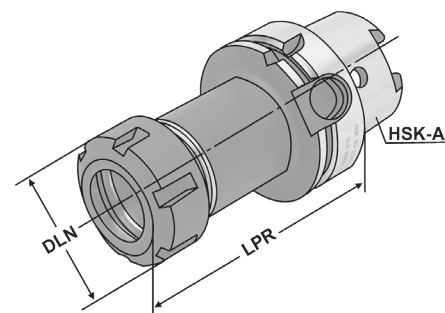

Bestell-Nr. Order no. Référence	HSK	DCONWS Spannbereich Capacity Capacité	Typ	LPR	DLN	THID
A32.02.10	HSK-A 32	1 - 10	426E ER 16	80	32	M10 x 1,5
A32.02.20	HSK-A 32	2 - 20	470E ER 32	85	50	M16 x 2,0
A40.02.10	HSK-A 40	1 - 10	426E ER 16	80	32	M10 x 1,5
A40.02.16	HSK-A 40	2 - 16	430E ER 25	80	42	M16 x 2,0
A40.02.20	HSK-A 40	2 - 20	470E ER 32	80	50	M16 x 2,0
A50.02.10	HSK-A 50	1 - 10	426E ER 16	100	32	M10 x 1,5
A50.02.16	HSK-A 50	2 - 16	430E ER 25	80	42	M16 x 2,0
A50.02.20	HSK-A 50	2 - 20	470E ER 32	100	50	M16 x 2,0
A63.02.10.0	HSK-A 63	1 - 10	426E ER 16	75	32	-
A63.02.13.0	HSK-A 63	2 - 13	428E ER 20	75	35	-
A63.02.16.0	HSK-A 63	2 - 16	430E ER 25	75	42	-
A63.02.20.0	HSK-A 63	2 - 20	470E ER 32	75	50	-
A63.02.26.0	HSK-A 63	3 - 26	472E ER 40	85	63	-
A63.02.10	HSK-A 63	1 - 10	426E ER 16	100	32	M10 x 1,5
A63.02.13	HSK-A 63	2 - 13	428E ER 20	100	35	M12 x 1,75
A63.02.16	HSK-A 63	2 - 16	430E ER 25	100	42	M16 x 2,0
A63.02.20	HSK-A 63	2 - 20	470E ER 32	100	50	M16 x 2,0
A63.02.26	HSK-A 63	3 - 26	472E ER 40	120	63	M16 x 2,0

Lieferumfang: Mit gewuchteter Spannmutter**Delivery:** With balanced clamping nut**Livraison:** Avec écrou de serrage équilibré

Collet chucks for collets ISO 15488 (DIN 6499) ER-system
Mandrins à pinces pour pinces ISO 15488 (DIN 6499) système ER

(DIN 69893-1 | HSK-A)



Verwendung:
Zur Aufnahme von Werkzeugen mit
Zylinderschaft in Spannzangen.

Application:
For mounting straight-shank tools in
collets.

Application:
Destiné à recevoir les outils avec les
queues de forme cylindrique dans les
pinces de serrage.

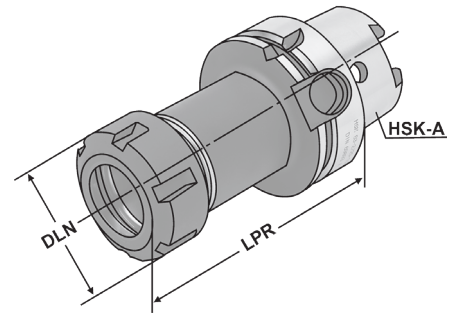

Bestell-Nr. Order no. Référence	HSK	DCONWS Spannbereich Capacity Capacité	Typ	LPR	DLN	THID
A63.02.10.130	HSK-A 63	1 - 10	426E ER 16	130	32	M10 x 1,5
A63.02.13.130	HSK-A 63	2 - 13	428E ER 20	130	35	M12 x 1,75
A63.02.16.130	HSK-A 63	2 - 16	430E ER 25	130	42	M16 x 2,0
A63.02.20.130	HSK-A 63	2 - 20	470E ER 32	130	50	M16 x 2,0
A63.02.26.130	HSK-A 63	3 - 26	472E ER 40	130	63	M16 x 2,0
A63.02.10.1	HSK-A 63	1 - 10	426E ER 16	160	32	M10 x 1,5
A63.02.13.1	HSK-A 63	2 - 13	428E ER 20	160	35	M12 x 1,75
A63.02.16.1	HSK-A 63	2 - 16	430E ER 25	160	42	M16 x 2,0
A63.02.20.1	HSK-A 63	2 - 20	470E ER 32	160	50	M16 x 2,0
A63.02.26.1	HSK-A 63	3 - 26	472E ER 40	160	63	M16 x 2,0
A63.02.10.3	HSK-A 63	1 - 10	426E ER 16	200	32	M10 x 1,5
A63.02.13.3	HSK-A 63	2 - 13	428E ER 20	200	35	M12 x 1,75
A63.02.16.3	HSK-A 63	2 - 16	430E ER 25	200	42	M16 x 2,0
A63.02.20.3	HSK-A 63	2 - 20	470E ER 32	200	50	M16 x 2,0
A63.02.26.3	HSK-A 63	3 - 26	472E ER 40	200	63	M16 x 2,0
A100.02.10	HSK-A 100	1 - 10	426E ER 16	100	32	M10 x 1,5
A100.02.16	HSK-A 100	2 - 16	430E ER 25	100	42	M16 x 2,0
A100.02.20	HSK-A 100	2 - 20	470E ER 32	100	50	M16 x 2,0
A100.02.26	HSK-A 100	3 - 26	472E ER 40	120	63	M16 x 2,0
A100.02.10.2	HSK-A 100	1 - 10	426E ER 16	160	32	M10 x 1,5
A100.02.16.2	HSK-A 100	2 - 16	430E ER 25	160	42	M16 x 2,0
A100.02.20.2	HSK-A 100	2 - 20	470E ER 32	160	50	M16 x 2,0
A100.02.26.2	HSK-A 100	3 - 26	472E ER 40	160	63	M16 x 2,0
A100.02.10.3	HSK-A 100	1 - 10	426E ER 16	200	32	M10 x 1,5
A100.02.16.3	HSK-A 100	2 - 16	430E ER 25	200	42	M16 x 2,0
A100.02.20.3	HSK-A 100	2 - 20	470E ER 32	200	50	M16 x 2,0
A100.02.26.3	HSK-A 100	3 - 26	472E ER 40	200	63	M16 x 2,0

Lieferumfang: Mit gewuchteter Spannmutter
Delivery: With balanced clamping nut
Livraison: Avec écrou de serrage équilibré



Collet chucks for collets ISO 15488 (DIN 6499) ER-system - Mini
Mandrins à pinces pour pinces ISO 15488 (DIN 6499) système ER - Mini

(DIN 69893-1 | HSK-A)



Verwendung:
Zur Aufnahme von Werkzeugen mit Zylinderschaft in Spannzangen.

Application:
For mounting straight-shank tools in collets.

Application:
Destiné à recevoir les outils avec les queues de forme cylindrique dans les pinces de serrage.

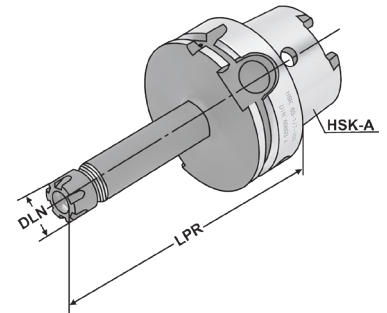

ISO
12164

Form
A

≤ 3µm

G2.5
25.000
min⁻¹

RFID
Chip

ISO
15488

13.04

Bestell-Nr. Order no. Référence	HSK	DCONWS Spannbereich Capacity Capacité	Typ	LPR	DLN	THID
A32.02.07.M	HSK-A 32	1 - 7	4008E ER 11	50	16	M5
A32.02.10.M	HSK-A 32	1 - 10	426E ER 16	50	22	-
A32.02.16.M	HSK-A 32	2 - 16	430E ER 25	80	35	M8
A40.02.07.M	HSK-A 40	1 - 7	4008E ER 11	40	16	-
A40.02.10.M	HSK-A 40	1 - 10	426E ER 16	80	22	M8
A50.02.07.M	HSK-A 50	1 - 7	4008E ER 11	60	16	M6
A50.02.10.M	HSK-A 50	1 - 10	426E ER 16	60	22	-
A63.02.07.1	HSK-A 63	1 - 7	4008E ER 11	100	16	M8 x 1,25
A63.02.07.2	HSK-A 63	1 - 7	4008E ER 11	160	16	M8 x 1,25
A63.02.07.10.1	HSK-A 63	1 - 10	426E ER 16	100	22	7/16" 20 UNF
A63.02.07.10.2	HSK-A 63	1 - 10	426E ER 16	160	22	7/16" 20 UNF
A63.02.07.13.1	HSK-A 63	1 - 13	428E ER 20	100	28	9/16" 18 UNF
A63.02.07.13.2	HSK-A 63	1 - 13	428E ER 20	160	28	9/16" 18 UNF
A63.02.07.16.1	HSK-A 63	2 - 16	430E ER 25	100	35	11/16" 16 UN
A63.02.07.16.2	HSK-A 63	2 - 16	430E ER 25	160	35	11/16" 16 UN

Lieferumfang: Mit gewichteter Spannmutter
Delivery: With balanced clamping nut
Livraison: Avec écrou de serrage équilibré



Precision collet chuck ER for collets ISO 15488 (DIN 6499) ER-system

Mandrin à pinces ER de précision pour pinces ISO 15488 (DIN 6499) système ER



Verwendung:
Zur Aufnahme von Werkzeugen mit Zylinderschaft in 3 µm-Spannzangen.

Application:
For mounting straight-shank tools in 3 µm-collets.

Application:
Pour le serrage d'outils avec queue cylindrique dans des pinces de serrage 3 µm.

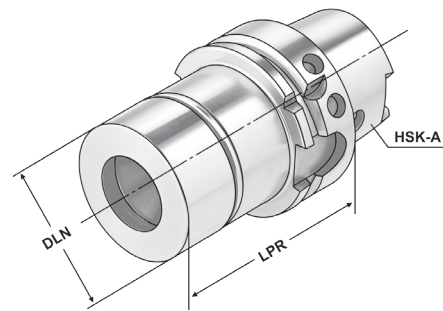

Bestell-Nr. Order no. Référence	HSK	DCONWS Spannbereich Capacity Capacité	Typ	LPR	LB	DLN	THID
A40.P2.20.070	HSK-A 40	2 - 20	470E ER 32	70	49,5	50	M16 x 2,0
A50.P2.20.080	HSK-A 50	2 - 20	470E ER 32	70	53	50	M16 x 2,0
A63.P2.20.080	HSK-A 63	2 - 20	470E ER 32	80	53	50	M16 x 2,0
A63.P2.20.100	HSK-A 63	2 - 20	470E ER 32	100	73	50	M16 x 2,0
A63.P2.20.125	HSK-A 63	2 - 20	470E ER 32	125	86	50	M16 x 2,0
A63.P2.20.150	HSK-A 63	2 - 20	470E ER 32	150	111	50	M16 x 2,0
A63.P2.20.200	HSK-A 63	2 - 20	470E ER 32	200	161	50	M16 x 2,0
A100.P2.20.100	HSK-A 100	2 - 20	470E ER 32	100	61	50	M16 x 2,0
A100.P2.20.125	HSK-A 100	2 - 20	470E ER 32	125	86	50	M16 x 2,0
A100.P2.20.150	HSK-A 100	2 - 20	470E ER 32	150	111	50	M16 x 2,0
A100.P2.20.200	HSK-A 100	2 - 20	470E ER 32	200	161	50	M16 x 2,0

Vorteile:

Exzellente Rundlaufgenauigkeit im System (Futter + Spannzange + Spannmutter)
 Extreme Haltekräfte (erhöht die Haltekraft um mindestens 60 % im Vergleich zu Standard ER-Futter)
 Glatte Spannmutter ohne Nuten für Hochgeschwindigkeitsbearbeitung

Advantages:

Excellent concentricity in the system (chuck + collet + clamping nut)
 Extremely strong holding force (increases the holding power by at least 60% compared to standard ER chuck)
 Plain clamping nut without grooves for high speed machining

Avantages:

Excellente précision de concentricité dans le système (mandrin + pince de serrage + écrou de serrage)
 La force de maintien extrême (augmente la force de maintien d'au moins à 60% par rapport aux mandrins standards ER)
 Ecrou de serrage lisse sans rainures pour l'usinage à haute vitesse

Hinweis:

Nur das Nennmaß DCONWS kann gespannt werden.

Note:

Only nominal size DCONWS can be clamped.

Observation:

Seulement la dimension nominale DCONWS peut être serrée.

Lieferumfang:

Inklusive Präzisions-Spannmutter

Delivery:

With precision clamping nut

Livraison:

Avec écrou de serrage de précision





Verwendung:

Zur Aufnahme von Werkzeugen mit Zylinderschaft nach DIN 1835 Form A+B+E und DIN 6535 Form HB+HE

Application:

For mounting straight-shank tools acc. DIN 1835 form A+B+E and DIN 6535 form HB+HE

Application:

Destiné à recevoir les outils avec les queues de forme cylindrique suivant DIN 1835 en forme A+B+E et DIN 6535 en forme HB+HE

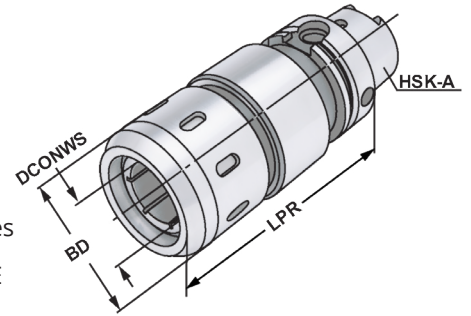

Bestell-Nr. Order no. Référence	HSK	DCONWS Spannbereich Capacity Capacité	Typ	DCONWS	LPR	BD
A63.64.20	HSK-A 63	3 - 20	HKS 20	20	95	53
A63.64.25	HSK-A 63	3 - 25	HKS 25	25	100	63
A63.64.32	HSK-A 63	3 - 32	HKS 32	32	110	68
A100.64.20	HSK-A 100	3 - 20	HKS 20	20	105	53
A100.64.25	HSK-A 100	3 - 25	HKS 25	25	105	63
A100.64.32	HSK-A 100	3 - 32	HKS 32	32	105	68

Größe Size Taille	20mm	25mm	32mm
Anzugsmoment Clamping torque Couple	50-70 Nm	80-100 Nm	80-100 Nm
Spannkraft Clamping force Tension	780 Nm	2000 Nm	2000 Nm

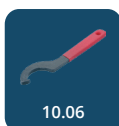

RELEASE THE BEAST



End mill holders DIN 6359 for end mills DIN 1835-B

(DIN 69893-1 | HSK-A)

Porte-fraises DIN 6359 pour queues cylindriques DIN 1835-B

**Verwendung:**

Zum Spannen von zylindrischen Werkzeugschäften mit seitlicher Spannfläche nach DIN 1835 Form B (Weldon).

Application:

For mounting straight-shank tools with lateral flat according to DIN 1835 form B (Weldon).

Application:

Pour le serrage d'outils avec queue cylindrique et avec méplat de serrage latérale suivant DIN 1835 forme B (Weldon).

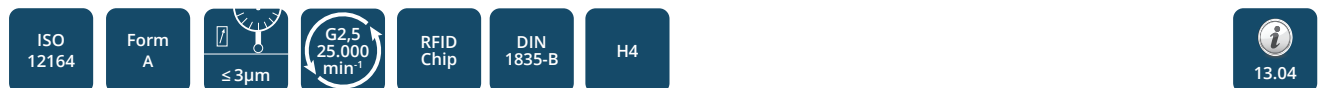
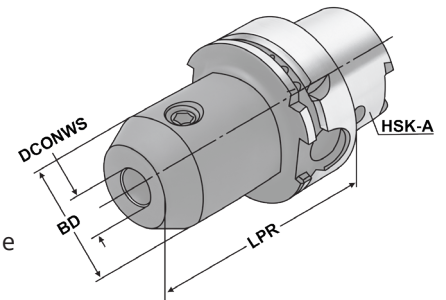

Bestell-Nr. Order no. Référence	HSK	DCONWS	TDCON	LPR	BD
A32.04.06	HSK-A 32	6	H4	60	25
A32.04.08	HSK-A 32	8	H4	60	28
A32.04.10	HSK-A 32	10	H4	65	35
A32.04.12	HSK-A 32	12	H4	70	42
A32.04.14	HSK-A 32	14	H4	75	44
A32.04.16	HSK-A 32	16	H4	75	48
A32.04.20	HSK-A 32	20	H4	90	50
A40.04.06	HSK-A 40	6	H4	60	25
A40.04.08	HSK-A 40	8	H4	60	28
A40.04.10	HSK-A 40	10	H4	60	35
A40.04.12	HSK-A 40	12	H4	70	42
A40.04.14	HSK-A 40	14	H4	75	44
A40.04.16	HSK-A 40	16	H4	75	40
A40.04.18	HSK-A 40	18	H4	85	40
A40.04.20	HSK-A 40	20	H4	85	40
A40.04.25	HSK-A 40	25	H4	100	45
A40.04.32	HSK-A 40	32	H4	105	60
A50.04.06	HSK-A 50	6	H4	65	25
A50.04.08	HSK-A 50	8	H4	65	28
A50.04.10	HSK-A 50	10	H4	65	35
A50.04.12	HSK-A 50	12	H4	80	42
A50.04.14	HSK-A 50	14	H4	80	44
A50.04.16	HSK-A 50	16	H4	80	48
A50.04.18	HSK-A 50	18	H4	80	50
A50.04.20	HSK-A 50	20	H4	80	52
A50.04.25	HSK-A 50	25	H4	110	60
A50.04.32	HSK-A 50	32	H4	110	60

Hinweis: Ab DCONWS = 25 mit zwei Spannschrauben
Note: From DCONWS = 25 on two clamping screws
Observation: A partir de DCONWS = 25 avec deux vis de serrage

Lieferumfang: Mit Spannschraube
Delivery: With clamping screw
Livraison: Avec vis de serrage



End mill holders DIN 6359 for end mills DIN 1835-B

(DIN 69893-1 | HSK-A)

Porte-fraises DIN 6359 pour queues cylindriques DIN 1835-B

**Verwendung:**

Zum Spannen von zylindrischen Werkzeugschäften mit seitlicher Spannfläche nach DIN 1835 Form B (Weldon).

Application:

For mounting straight-shank tools with lateral flat according to DIN 1835 form B (Weldon).

Application:

Pour le serrage d'outils avec queue cylindrique et avec méplat de serrage latérale suivant DIN 1835 forme B (Weldon).

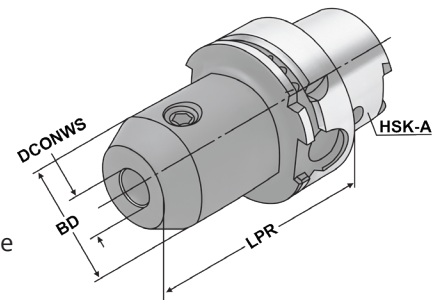

Bestell-Nr. Order no. Référence	HSK	DCONWS	TDCON	LPR	BD
A63.04.06	HSK-A 63	6	H4	65	25
A63.04.08	HSK-A 63	8	H4	65	28
A63.04.10	HSK-A 63	10	H4	65	35
A63.04.12	HSK-A 63	12	H4	80	42
A63.04.14	HSK-A 63	14	H4	80	44
A63.04.16	HSK-A 63	16	H4	80	48
A63.04.18	HSK-A 63	18	H4	80	50
A63.04.20	HSK-A 63	20	H4	80	52
A63.04.25	HSK-A 63	25	H4	110	65
A63.04.32	HSK-A 63	32	H4	110	72
A63.04.40	HSK-A 63	40	H4	125	80
A63.04.06.1	HSK-A 63	6	H4	100	25
A63.04.08.1	HSK-A 63	8	H4	100	28
A63.04.10.1	HSK-A 63	10	H4	100	35
A63.04.12.1	HSK-A 63	12	H4	100	35
A63.04.14.1	HSK-A 63	14	H4	100	44
A63.04.16.1	HSK-A 63	16	H4	100	48
A63.04.18.1	HSK-A 63	18	H4	100	50
A63.04.20.1	HSK-A 63	20	H4	100	52
A63.04.06.130	HSK-A 63	6	H4	130	25
A63.04.08.130	HSK-A 63	8	H4	130	28
A63.04.10.130	HSK-A 63	10	H4	130	35
A63.04.12.130	HSK-A 63	12	H4	130	35
A63.04.14.130	HSK-A 63	14	H4	130	44
A63.04.16.130	HSK-A 63	16	H4	130	48
A63.04.18.130	HSK-A 63	18	H4	130	50
A63.04.20.130	HSK-A 63	20	H4	130	52
A63.04.06.2	HSK-A 63	6	H4	160	25
A63.04.08.2	HSK-A 63	8	H4	160	28
A63.04.10.2	HSK-A 63	10	H4	160	35
A63.04.12.2	HSK-A 63	12	H4	160	35
A63.04.14.2	HSK-A 63	14	H4	160	44
A63.04.16.2	HSK-A 63	16	H4	160	48
A63.04.18.2	HSK-A 63	18	H4	160	50
A63.04.20.2	HSK-A 63	20	H4	160	52

End mill holders DIN 6359 for end mills DIN 1835-B

(DIN 69893-1 | HSK-A)

Porte-fraises DIN 6359 pour queues cylindriques DIN 1835-B

**Verwendung:**

Zum Spannen von zylindrischen Werkzeugschäften mit seitlicher Spannfläche nach DIN 1835 Form B (Weldon).

Application:

For mounting straight-shank tools with lateral flat according to DIN 1835 form B (Weldon).

Application:

Pour le serrage d'outils avec queue cylindrique et avec méplat de serrage latérale suivant DIN 1835 forme B (Weldon).

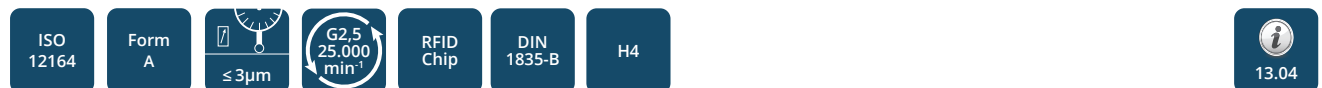
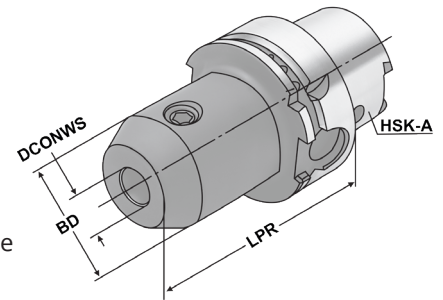

Bestell-Nr. Order no. Référence	HSK	DCONWS	TDCON	LPR	BD
A80.04.06	HSK-A 80	6	H4	80	25
A80.04.08	HSK-A 80	8	H4	80	28
A80.04.10	HSK-A 80	10	H4	80	35
A80.04.12	HSK-A 80	12	H4	80	42
A80.04.14	HSK-A 80	14	H4	80	44
A80.04.16	HSK-A 80	16	H4	100	48
A80.04.18	HSK-A 80	18	H4	100	50
A80.04.20	HSK-A 80	20	H4	100	52
A80.04.25	HSK-A 80	25	H4	100	65
A80.04.32	HSK-A 80	32	H4	110	72
A80.04.40	HSK-A 80	40	H4	120	80
A100.04.06	HSK-A 100	6	H4	80	25
A100.04.08	HSK-A 100	8	H4	80	28
A100.04.10	HSK-A 100	10	H4	80	35
A100.04.12	HSK-A 100	12	H4	80	42
A100.04.14	HSK-A 100	14	H4	80	44
A100.04.16	HSK-A 100	16	H4	100	48
A100.04.18	HSK-A 100	18	H4	100	50
A100.04.20	HSK-A 100	20	H4	100	52
A100.04.25	HSK-A 100	25	H4	100	65
A100.04.32	HSK-A 100	32	H4	100	72
A100.04.40	HSK-A 100	40	H4	105	80
A100.04.06.2	HSK-A 100	6	H4	160	25
A100.04.08.2	HSK-A 100	8	H4	160	28
A100.04.10.2	HSK-A 100	10	H4	160	35
A100.04.12.2	HSK-A 100	12	H4	160	35
A100.04.14.2	HSK-A 100	14	H4	160	44
A100.04.16.2	HSK-A 100	16	H4	160	48
A100.04.18.2	HSK-A 100	18	H4	160	50
A100.04.20.2	HSK-A 100	20	H4	160	52
A100.04.25.2	HSK-A 100	25	H4	160	65
A100.04.32.2	HSK-A 100	32	H4	160	72
A100.04.40.2	HSK-A 100	40	H4	160	80

Hinweis:**Note:****Observation:**

Ab DCONWS = 25 mit zwei Spannschrauben
From DCONWS = 25 on two clamping screws

A partir de DCONWS = 25 avec deux vis de serrage

Lieferumfang:**Delivery:****Livraison:**

Mit Spannschraube
With clamping screw

Avec vis de serrage

End mill holders DIN 6359 with coolant channels for end mills DIN 1835-B

Porte-fraises DIN 6359 avec canaux d'arrosage pour queues cylindriques DIN 1835-B

**Verwendung:**

Zum Spannen von zylindrischen Werkzeugschäften mit seitlicher Spannfläche nach DIN 1835 Form B (Weldon). Mit Kühlkanälen für optimale Kühlung der Werkzeugschneide.

Application:

For mounting straight-shank tools with lateral flat according to DIN 1835 form B (Weldon). With coolant channels for optimal coolant at the cutting edge.

Application:

Pour le serrage d'outils avec queue cylindrique et avec méplat de serrage latéral suivant DIN 1835 forme B (Weldon). Avec canaux d'arrosage pour refroidissement optimal des coupes.

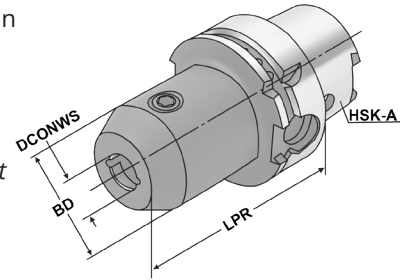

Bestell-Nr. Order no. Référence	HSK	DCONWS	TDCON	LPR	BD
A63.04.06.K	HSK-A 63	6	H4	65	25
A63.04.08.K	HSK-A 63	8	H4	65	28
A63.04.10.K	HSK-A 63	10	H4	65	35
A63.04.12.K	HSK-A 63	12	H4	80	42
A63.04.14.K	HSK-A 63	14	H4	80	44
A63.04.16.K	HSK-A 63	16	H4	80	48
A63.04.18.K	HSK-A 63	18	H4	80	50
A63.04.20.K	HSK-A 63	20	H4	80	52
A63.04.25.K	HSK-A 63	25	H4	110	65
A63.04.32.K	HSK-A 63	32	H4	110	72
A63.04.40.K	HSK-A 63	40	H4	125	80
A63.04.06.1.K	HSK-A 63	6	H4	100	25
A63.04.08.1.K	HSK-A 63	8	H4	100	28
A63.04.10.1.K	HSK-A 63	10	H4	100	35
A63.04.12.1.K	HSK-A 63	12	H4	100	42
A63.04.14.1.K	HSK-A 63	14	H4	100	44
A63.04.16.1.K	HSK-A 63	16	H4	100	48
A63.04.18.1.K	HSK-A 63	18	H4	100	50
A63.04.20.1.K	HSK-A 63	20	H4	100	52
A63.04.06.130.K	HSK-A 63	6	H4	130	25
A63.04.08.130.K	HSK-A 63	8	H4	130	28
A63.04.10.130.K	HSK-A 63	10	H4	130	35
A63.04.12.130.K	HSK-A 63	12	H4	130	35
A63.04.14.130.K	HSK-A 63	14	H4	130	44
A63.04.16.130.K	HSK-A 63	16	H4	130	48
A63.04.18.130.K	HSK-A 63	18	H4	130	50
A63.04.20.130.K	HSK-A 63	20	H4	130	52
A100.04.06.K	HSK-A 100	6	H4	80	25
A100.04.08.K	HSK-A 100	8	H4	80	28
A100.04.10.K	HSK-A 100	10	H4	80	35
A100.04.12.K	HSK-A 100	12	H4	80	42
A100.04.14.K	HSK-A 100	14	H4	80	44
A100.04.16.K	HSK-A 100	16	H4	100	48
A100.04.18.K	HSK-A 100	18	H4	100	50
A100.04.20.K	HSK-A 100	20	H4	100	52
A100.04.25.K	HSK-A 100	25	H4	100	65
A100.04.32.K	HSK-A 100	32	H4	100	72
A100.04.40.K	HSK-A 100	40	H4	105	80

End mill holders DIN 6359 for end mills DIN 1835-E

(DIN 69893-1 | HSK-A)

Porte-fraises DIN 6359 pour queues cylindriques DIN 1835-E

**Verwendung:**

Zum Spannen von zylindrischen Werkzeugschäften mit geneigter Spannfläche nach DIN 1835 Form E (Whistle Notch).

Application:

For mounting straight-shank tools and inclined flat according to DIN 1835 form E (Whistle Notch).

Application:

Pour le serrage d'outils avec queue cylindrique et avec méplat incliné suivant DIN 1835 forme E (Whistle Notch).

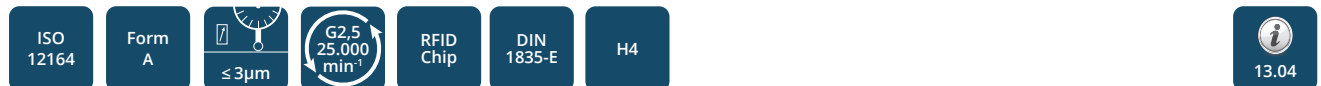
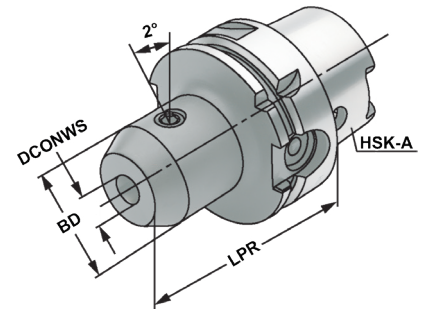

Bestell-Nr. Order no. Référence	HSK	DCONWS	TDCON	LPR	BD
A32.05.06	HSK-A 32	6	H4	80	25
A32.05.08	HSK-A 32	8	H4	80	28
A32.05.10	HSK-A 32	10	H4	80	32
A32.05.12	HSK-A 32	12	H4	80	32
A32.05.14	HSK-A 32	14	H4	80	32
A32.05.16	HSK-A 32	16	H4	90	32
A32.05.18	HSK-A 32	18	H4	90	34
A32.05.20	HSK-A 32	20	H4	90	34
A40.05.06	HSK-A 40	6	H4	80	25
A40.05.08	HSK-A 40	8	H4	80	28
A40.05.10	HSK-A 40	10	H4	80	35
A40.05.12	HSK-A 40	12	H4	90	42
A40.05.14	HSK-A 40	14	H4	90	44
A40.05.16	HSK-A 40	16	H4	90	48
A40.05.18	HSK-A 40	18	H4	90	40
A40.05.20	HSK-A 40	20	H4	90	40
A40.05.25	HSK-A 40	25	H4	100	46
A40.05.32	HSK-A 40	32	H4	110	54
A50.05.06	HSK-A 50	6	H4	80	25
A50.05.08	HSK-A 50	8	H4	80	28
A50.05.10	HSK-A 50	10	H4	80	35
A50.05.12	HSK-A 50	12	H4	90	42
A50.05.14	HSK-A 50	14	H4	90	44
A50.05.16	HSK-A 50	16	H4	90	48
A50.05.18	HSK-A 50	18	H4	90	50
A50.05.20	HSK-A 50	20	H4	100	52
A50.05.25	HSK-A 50	25	H4	110	60
A50.05.32	HSK-A 50	32	H4	110	60

Hinweis: Ab DCONWS = 25 mit zwei Spannschrauben
Note: From DCONWS = 25 on two clamping screws
Observation: A partir de DCONWS = 25 avec deux vis de serrage

Lieferumfang: Mit Spannschraube und axialer Verstellerschraube
Delivery: With clamping screw and axial adjustment bolt
Livraison: Avec vis de serrage et vis de butée axiale



End mill holders DIN 6359 for end mills DIN 1835-E

(DIN 69893-1 | HSK-A)

Porte-fraises DIN 6359 pour queues cylindriques DIN 1835-E

**Verwendung:**

Zum Spannen von zylindrischen Werkzeugschäften mit geneigter Spannfläche nach DIN 1835 Form E (Whistle Notch).

Application:

For mounting straight-shank tools and inclined flat according to DIN 1835 form E (Whistle Notch).

Application:

Pour le serrage d'outils avec queue cylindrique et avec méplat incliné suivant DIN 1835 forme E (Whistle Notch).

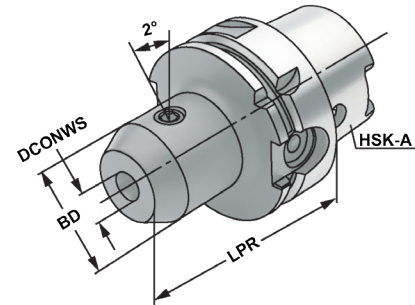

Bestell-Nr. Order no. Référence	HSK	DCONWS	TDCON	LPR	BD
A63.05.06	HSK-A 63	6	H4	80	25
A63.05.08	HSK-A 63	8	H4	80	28
A63.05.10	HSK-A 63	10	H4	80	35
A63.05.12	HSK-A 63	12	H4	90	42
A63.05.14	HSK-A 63	14	H4	90	44
A63.05.16	HSK-A 63	16	H4	100	48
A63.05.18	HSK-A 63	18	H4	100	50
A63.05.20	HSK-A 63	20	H4	100	52
A63.05.25	HSK-A 63	25	H4	110	65
A63.05.32	HSK-A 63	32	H4	110	72
A80.05.06	HSK-A 80	6	H4	90	25
A80.05.08	HSK-A 80	8	H4	90	28
A80.05.10	HSK-A 80	10	H4	90	35
A80.05.12	HSK-A 80	12	H4	100	42
A80.05.14	HSK-A 80	14	H4	100	44
A80.05.16	HSK-A 80	16	H4	100	48
A80.05.18	HSK-A 80	18	H4	100	50
A80.05.20	HSK-A 80	20	H4	110	52
A80.05.25	HSK-A 80	25	H4	110	65
A80.05.32	HSK-A 80	32	H4	120	72
A100.05.06	HSK-A 100	6	H4	90	25
A100.05.08	HSK-A 100	8	H4	90	28
A100.05.10	HSK-A 100	10	H4	90	35
A100.05.12	HSK-A 100	12	H4	100	42
A100.05.14	HSK-A 100	14	H4	100	44
A100.05.16	HSK-A 100	16	H4	100	48
A100.05.18	HSK-A 100	18	H4	100	50
A100.05.20	HSK-A 100	20	H4	110	52
A100.05.25	HSK-A 100	25	H4	120	65
A100.05.32	HSK-A 100	32	H4	120	72
A100.05.40	HSK-A 100	40	H4	120	80

Hinweis: Ab DCONWS = 25 mit zwei Spannschrauben
Note: From DCONWS = 25 on two clamping screws
Observation: A partir de DCONWS = 25 avec deux vis de serrage

Lieferumfang: Mit Spannschraube und axialer Verstellechraube
Delivery: With clamping screw and axial adjustment bolt
Livraison: Avec vis de serrage et vis de butée axiale



Milling arbors for screw-in cutters
Porte-fraises pour fraises à queue fileté

(DIN 69893-1 | HSK-A)



Verwendung:
Zur Aufnahme von Einschraubfräser mit Gewinde.

Application:
For mounting screw-in cutters with thread.

Application:
Pour le serrage de fraises à queue fileté.

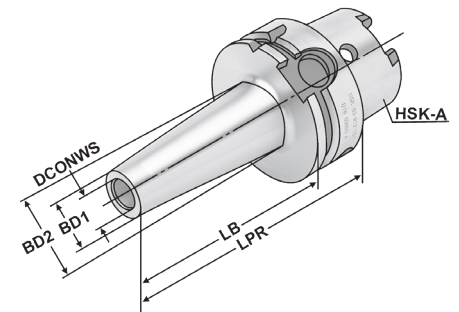

Bestell-Nr. Order no. Référence	HSK	THSZWS	DCONWS	BD1	BD2	LPR	LB
A63.06.06	HSK-A 63	M6	6,5	10	13	51	25
A63.06.08	HSK-A 63	M8	8,5	13	15	51	25
A63.06.08.1	HSK-A 63	M8	8,5	13	23	76	50
A63.06.08.2	HSK-A 63	M8	8,5	13	23	101	75
A63.06.10	HSK-A 63	M10	10,5	18	20	51	25
A63.06.10.1	HSK-A 63	M10	10,5	18	23	76	50
A63.06.10.3	HSK-A 63	M10	10,5	18	32	126	100
A63.06.10.5	HSK-A 63	M10	10,5	18	37	176	150
A63.06.12	HSK-A 63	M12	12,5	21	24	51	25
A63.06.12.1	HSK-A 63	M12	12,5	21	24	76	50
A63.06.12.2	HSK-A 63	M12	12,5	21	31	101	75
A63.06.12.3	HSK-A 63	M12	12,5	21	33	126	100
A63.06.12.5	HSK-A 63	M12	12,5	21	40	176	150
A63.06.16	HSK-A 63	M16	17	29	29	51	25
A63.06.16.1	HSK-A 63	M16	17	29	34	76	50
A63.06.16.2	HSK-A 63	M16	17	29	34	101	75
A63.06.16.3	HSK-A 63	M16	17	29	36	126	100
A63.06.16.5	HSK-A 63	M16	17	29	43	176	150
A100.06.08.1	HSK-A 100	M8	8,5	13	23	79	50
A100.06.10.1	HSK-A 100	M10	10,5	18	23	79	50
A100.06.10.3	HSK-A 100	M10	10,5	18	32	129	100
A100.06.10.5	HSK-A 100	M10	10,5	18	37	179	150
A100.06.12.1	HSK-A 100	M12	12,5	21	24	79	50
A100.06.12.3	HSK-A 100	M12	12,5	21	33	129	100
A100.06.12.5	HSK-A 100	M12	12,5	21	40	179	150
A100.06.16.1	HSK-A 100	M16	17	29	34	79	50
A100.06.16.3	HSK-A 100	M16	17	29	36	129	100
A100.06.16.5	HSK-A 100	M16	17	29	43	179	150

Empfohlenes Anzugsmoment
Recommended tightening torques
Torques de serrage recommandés

M6	10 Nm
M8	25 Nm
M10	40 Nm
M12	60 Nm
M16	50 Nm



5.49

Combi shell mill holders DIN 6358
 Porte-fraises à double usage DIN 6358

(DIN 69893-1 | HSK-A)



Verwendung:
 Zur Aufnahme von Walzen-, Walzenstirnfräsern oder Messerköpfen mit Längs- oder Quernut.

Application:
 For mounting milling cutters with transverse or longitudinal groove.

Application:
 Destiné à recevoir les porte-fraises, les fraises cylindriques ou les têtes de fraisage avec rainure longitudinale et transversale.

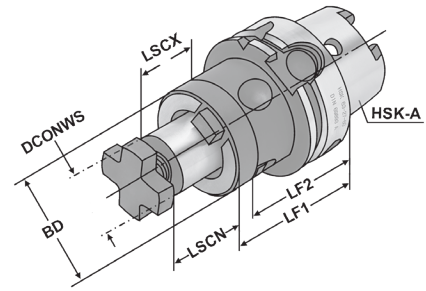

ISO 12164 Form A $\leq 5\mu\text{m}$ G6.3 15.000 min⁻¹ RFID Chip DIN 6358 h6

Bestell-Nr. Order no. Référence	HSK	DCONWS	TCDCON	LF1	LF2	LSCN	LSCX	BD
A32.10.16	HSK-A 32	16	h6	55	45	17	27	32
A32.10.22	HSK-A 32	22	h6	55	43	19	31	40
A32.10.27	HSK-A 32	27	h6	65	53	21	33	48
A32.10.32	HSK-A 32	32	h6	65	51	24	38	58
A32.10.40	HSK-A 32	40	h6	65	51	27	41	70
<hr/>								
A40.10.16	HSK-A 40	16	h6	50	40	17	27	32
A40.10.22	HSK-A 40	22	h6	50	38	19	31	40
A40.10.27	HSK-A 40	27	h6	65	53	21	33	48
A40.10.32	HSK-A 40	32	h6	65	51	24	38	58
<hr/>								
A50.10.16	HSK-A 50	16	h6	50	40	17	27	32
A50.10.22	HSK-A 50	22	h6	50	38	19	31	40
A50.10.27	HSK-A 50	27	h6	65	53	21	33	48
A50.10.32	HSK-A 50	32	h6	65	51	24	38	58
<hr/>								
A63.10.16	HSK-A 63	16	h6	60	50	17	27	32
A63.10.22	HSK-A 63	22	h6	60	48	19	31	40
A63.10.27	HSK-A 63	27	h6	60	48	21	33	48
A63.10.32	HSK-A 63	32	h6	60	46	24	38	58
A63.10.40	HSK-A 63	40	h6	70	56	27	41	70
A63.10.16.1	HSK-A 63	16	h6	100	90	17	27	32
A63.10.22.1	HSK-A 63	22	h6	100	88	19	31	40
A63.10.27.1	HSK-A 63	27	h6	100	88	21	33	48
A63.10.32.1	HSK-A 63	32	h6	100	86	24	38	58
<hr/>								
A80.10.16	HSK-A 80	16	h6	60	50	17	27	32
A80.10.22	HSK-A 80	22	h6	60	48	19	31	40
A80.10.27	HSK-A 80	27	h6	60	48	21	33	48
A80.10.32	HSK-A 80	32	h6	60	46	24	38	58
A80.10.40	HSK-A 80	40	h6	70	56	27	41	70
<hr/>								
A100.10.16	HSK-A 100	16	h6	60	50	17	27	32
A100.10.22	HSK-A 100	22	h6	60	48	19	31	40
A100.10.27	HSK-A 100	27	h6	60	48	21	33	48
A100.10.32	HSK-A 100	32	h6	60	46	24	38	58
A100.10.40	HSK-A 100	40	h6	70	56	27	41	70

Lieferumfang: Mit Fräseranzugsschraube, Mitnehmerring und Passfeder
Delivery: With tightening bolt, driving ring and feather key
Livraison: Avec vis de serrage, bague d'entraînement et clavette
 K24

Shell mill holders DIN 6357 with enlarged contact face and coolant exit bores on the end face
 Porte-fraises à trou lisse DIN 6357 avec surface de contact agrandie et arrosage frontal



Verwendung:
 Zur Aufnahme von Messerköpfen und Fräsern mit Quernut.

Application:
 For mounting milling cutters with transversal groove.

Application:
 Destiné à recevoir les fraises et les fraises avec des rainures transversales.

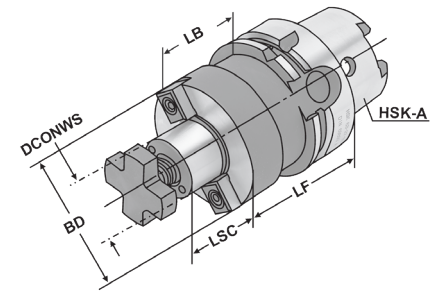

Bestell-Nr. Order no. Référence	HSK	DCONWS	TCDCON	LF	LSC	LB	BD
A40.11.16	HSK-A 40	16	h6	50	17	30	40
A40.11.22	HSK-A 40	22	h6	50	19	30	48
A40.11.27	HSK-A 40	27	h6	55	21	35	60
A40.11.32	HSK-A 40	32	h6	60	24	40	78
A50.11.16	HSK-A 50	16	h6	50	17	24	40
A50.11.22	HSK-A 50	22	h6	60	19	34	48
A50.11.27	HSK-A 50	27	h6	60	21	34	60
A50.11.32	HSK-A 50	32	h6	60	24	34	78
A63.11.16	HSK-A 63	16	h6	50	17	24	38
A63.11.22	HSK-A 63	22	h6	50	19	24	48
A63.11.27	HSK-A 63	27	h6	60	21	34	58
A63.11.32	HSK-A 63	32	h6	60	24	34	78
A63.11.40	HSK-A 63	40	h6	60	27	34	88
A63.11.16.1	HSK-A 63	16	h6	100	17	74	38
A63.11.22.1	HSK-A 63	22	h6	100	19	74	48
A63.11.27.1	HSK-A 63	27	h6	100	21	74	58
A63.11.32.1	HSK-A 63	32	h6	100	24	74	78
A63.11.40.1	HSK-A 63	40	h6	100	27	74	88
A63.11.16.2	HSK-A 63	16	h6	160	17	134	38
A63.11.22.2	HSK-A 63	22	h6	160	19	134	48
A63.11.27.2	HSK-A 63	27	h6	160	21	134	58
A63.11.32.2	HSK-A 63	32	h6	160	24	134	78
A63.11.40.2	HSK-A 63	40	h6	160	27	134	88

DCONWS = 40

Für große Planfräser mit vier zusätzlichen Gewindebohrungen nach DIN 2079.
 For large diameter face mill cutters with four additional threaded holes according to DIN 2079.
 Pour fraises à surfacer à grands diamètres avec 4 taraudages supplémentaires suivant DIN 2079.

Lieferumfang: Mit Mitnehmersteinen, Kreuzschraube und Zylinderkopfschraube nach DIN 912 für Fräser mit innerer Kühlmittelzufuhr.

Delivery: With drivers, cross head retaining screw and cylinder head retaining screw for cutters with central coolant.

Livraison: Avec tenon d entraînement, vis cruciforme et vis à têtes cylindrique suivant DIN 912 pour les fraises avec arrosage central.





Shell mill holders DIN 6357 with enlarged contact face and coolant exit bores on the end face
 Porte-fraises à trou lisse DIN 6357 avec surface de contact agrandie et arrosage frontal



Verwendung:
 Zur Aufnahme von Messerköpfen und Fräsern mit Quernut.

Application:
 For mounting milling cutters with transversal groove.

Application:
 Destiné à recevoir les fraises et les fraises avec des rainures transversales.

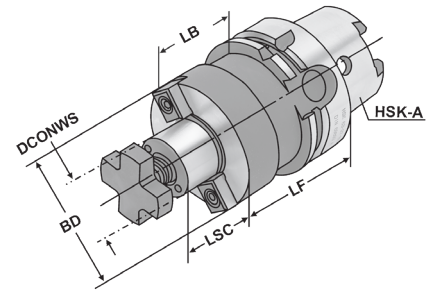

Bestell-Nr. Order no. Référence	HSK	DCONWS	TCDCON	LF	LSC	LB	BD
A80.11.22	HSK-A 80	22	h6	50	19	24	48
A80.11.27	HSK-A 80	27	h6	50	21	24	58
A80.11.32	HSK-A 80	32	h6	60	24	34	78
A80.11.40	HSK-A 80	40	h6	60	27	34	88
A100.11.16	HSK-A 100	16	h6	50	17	21	38
A100.11.22	HSK-A 100	22	h6	50	19	21	48
A100.11.27	HSK-A 100	27	h6	50	21	21	58
A100.11.32	HSK-A 100	32	h6	50	24	21	78
A100.11.40	HSK-A 100	40	h6	70	27	41	88
A100.11.60	HSK-A 100	60	h6	70	40	41	130
A100.11.16.1	HSK-A 100	16	h6	100	17	71	38
A100.11.22.1	HSK-A 100	22	h6	100	19	71	48
A100.11.27.1	HSK-A 100	27	h6	100	21	71	58
A100.11.32.1	HSK-A 100	32	h6	100	24	71	78
A100.11.40.1	HSK-A 100	40	h6	100	27	71	88
A100.11.16.2	HSK-A 100	16	h6	160	17	131	38
A100.11.22.2	HSK-A 100	22	h6	160	19	131	48
A100.11.27.2	HSK-A 100	27	h6	160	21	131	58
A100.11.32.2	HSK-A 100	32	h6	160	24	131	78
A100.11.40.2	HSK-A 100	40	h6	160	27	131	88

DCONWS = 40 & 60 Für große Planfräser mit vier zusätzlichen Gewindebohrungen nach DIN 2079.
 For large diameter face mill cutters with four additional threaded holes according to DIN 2079.
 Pour fraises à surfacer à grands diamètres avec 4 taraudages supplémentaires suivant DIN 2079.

Lieferumfang: Mit Mitnehmersteinen, Kreuzschraube und Zylinderkopfschraube nach DIN 912 für Fräser mit innerer Kühlmittelzufuhr.
 Bei DCONWS = 60 nur mit vier Befestigungsschrauben nach DIN 912.

Delivery: With drivers, cross head retaining screw and cylinder head retaining screw for cutters with central coolant.
 For DCONWS = 60 only with four fixation screws according to DIN 912.

Livraison: Avec tenon d entraînement, vis cruciforme et vis à têtes cylindrique suivant DIN 912 pour les fraises avec arrosage central.
 Pour DCONWS = 60 est seulement avec quatre vis de fixation suivant DIN 912.



Adaptor sleeves for MT with tang DIN 6383
 Douilles de réduction pour CM à tenon DIN 6383

(DIN 69893-1 | HSK-A)



Verwendung:
 Zur Aufnahme von Werkzeugen mit Morsekegelschaft und Austreibblappen nach DIN 228-1 Form B.

Application:
 For mounting tools with Morse taper shank and tang according to DIN 228-1 form B.

Application:
 Pour le serrage d'outils avec queue cône Morse et tenon suivant DIN 228-1 forme B.

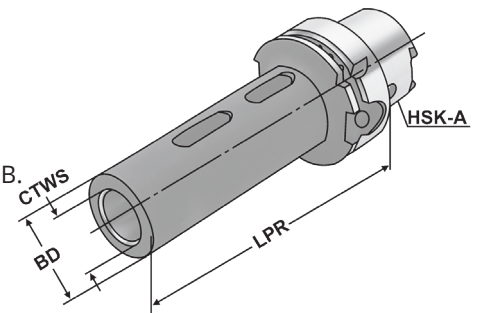

ISO 12164 Form A $\leq 5\mu\text{m}$ G6.3 15.000 min⁻¹ RFID Chip DIN 6383 AT5

Bestell-Nr. Order no. Référence	HSK	CTWS	TDCON	LPR	BD
A50.07.01	HSK-A 50	1	AT5	100	25
A50.07.02	HSK-A 50	2	AT5	120	32
A50.07.03	HSK-A 50	3	AT5	140	40
A63.07.01	HSK-A 63	1	AT5	100	25
A63.07.02	HSK-A 63	2	AT5	120	32
A63.07.03	HSK-A 63	3	AT5	140	40
A63.07.04	HSK-A 63	4	AT5	160	48
A80.07.01	HSK-A 80	1	AT5	110	25
A80.07.02	HSK-A 80	2	AT5	120	32
A80.07.03	HSK-A 80	3	AT5	140	40
A80.07.04	HSK-A 80	4	AT5	160	48
A100.07.01	HSK-A 100	1	AT5	110	25
A100.07.02	HSK-A 100	2	AT5	120	32
A100.07.03	HSK-A 100	3	AT5	150	40
A100.07.04	HSK-A 100	4	AT5	170	48
A100.07.05	HSK-A 100	5	AT5	200	63



Adaptor sleeves for MT with drawbar thread DIN 6364
 Douilles de réduction pour CM avec filetage DIN 6364

(DIN 69893-1 | HSK-A)



Verwendung:
 Zum Spannen von Werkzeugen mit Morsekegelschaft und Anzugsgewinde nach DIN 228-1 Form A.

Application:
 For clamping tools with Morse taper shank and thread according to DIN 228-1 form A.

Application:
 Pour le serrage d'outils avec queue cône Morse et filetage suivant DIN 228-1 forme A.

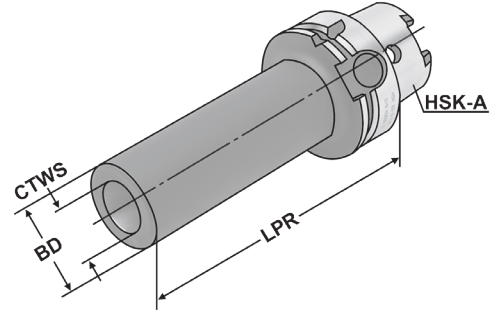

ISO 12164 Form A $\leq 5\mu\text{m}$ G6.3 15.000 min⁻¹ RFID Chip DIN 6364 AT5

Bestell-Nr. Order no. Référence	HSK	CTWS	THID	LPR	BD
A50.08.01	HSK-A 50	1	M6	100	25
A50.08.02	HSK-A 50	2	M10	120	32
A50.08.03	HSK-A 50	3	M12	140	40
A63.08.01	HSK-A 63	1	M6	100	25
A63.08.02	HSK-A 63	2	M10	120	32
A63.08.03	HSK-A 63	3	M12	140	40
A63.08.04	HSK-A 63	4	M16	160	48
A80.08.01	HSK-A 80	1	M6	110	25
A80.08.02	HSK-A 80	2	M10	120	32
A80.08.03	HSK-A 80	3	M12	150	40
A80.08.04	HSK-A 80	4	M16	170	48
A100.08.01	HSK-A 100	1	M6	110	25
A100.08.02	HSK-A 100	2	M10	120	32
A100.08.03	HSK-A 100	3	M12	150	40
A100.08.04	HSK-A 100	4	M16	170	48
A100.08.05	HSK-A 100	5	M20	200	63

Lieferumfang: Mit eingebauter Fräseranzugsschraube
Delivery: With built-in tightening bolt
Livraison: Avec vis de serrage montée

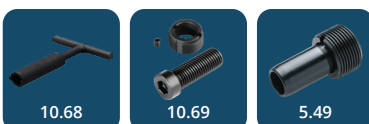

Quick change tapping chucks with length compensation on compression and expansion

Mandrins de taraudage à changement rapide avec compensation longitudinale à la compression et traction



Verwendung:

Zur Aufnahme von Schnellwechsel-Ein-sätzen für Gewindebohrer.

Application:

For the chucking of quick change adaptors for taps.

Application:

Pour le serrage d'adaptateurs porte-tarauts à changement rapide.

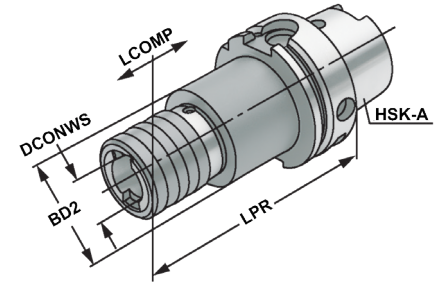

ISO
12164

Form
A

RFID
Chip

13.04

Bestell-Nr. Order no. Référence	HSK	Spannbereich Capacity Capacité	SZID	DCONWS	LPR	BD2	LCOMP
A32.16.12	HSK-A 32	M3 - M14	1	19	80	41	7
A40.16.12	HSK-A 40	M3 - M14	1	19	95	36	7
A50.16.12	HSK-A 50	M3 - M14	1	19	100	36	7
A50.16.20	HSK-A 50	M5 - M22	2	31	140	53	12
A63.16.12	HSK-A 63	M3 - M14	1	19	102	50	7
A63.16.20	HSK-A 63	M5 - M22	2	31	140	54	12
A63.16.36	HSK-A 63	M14 - M36	3	48	210	86	17,5
A80.16.12	HSK-A 80	M3 - M14	1	19	72	41	7
A80.16.20	HSK-A 80	M5 - M22	2	31	108	60	10
A80.16.36	HSK-A 80	M14 - M36	3	48	141	86	17,5
A100.16.12	HSK-A 100	M3 - M14	1	19	112	38	7
A100.16.20	HSK-A 100	M5 - M22	2	31	148	54	12
A100.16.36	HSK-A 100	M14 - M36	3	48	210	86	17,5

Hinweis: Für Bearbeitungszentren ohne Synchronspindel.
Note: For machining centres without synchronous spindle.
Observation: Pour centres d'usinage sans broche synchrone.



Quick change tapping chucks without length compensation on compression and expansion

Mandrins de taraudage à changement rapide sans compensation longitudinale à la compression et traction



Verwendung:

Zur Aufnahme von Schnellwechsel-Ein-sätzen für Gewindebohrer.

Application:

For the chucking of quick change adaptors for taps.

Application:

Pour le serrage d'adapteurs porte-tarauts à changement rapide.

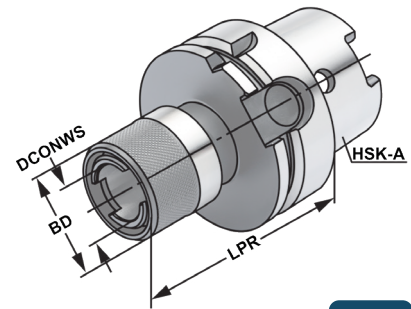

ISO 12164 Form A RFID Chip

13.04

Bestell-Nr. Order no. Référence	HSK	Spannbereich Capacity Capacité	SZID	DCONWS	LPR	BD
A50.16.12.1	HSK-A 50	M3 – M14	1	19	65	38
A50.16.20.1	HSK-A 50	M5 – M22	2	31	100	54
A63.16.12.1	HSK-A 63	M3 – M14	1	19	65	38
A63.16.20.1	HSK-A 63	M5 – M22	2	31	100	54
A100.16.12.1	HSK-A 100	M3 – M14	1	19	80	38
A100.16.20.1	HSK-A 100	M5 – M22	2	31	90	54
A100.16.36.1	HSK-A 100	M14 – M36	3	48	130	86

Hinweis: Für Bearbeitungszentren mit Synchronspindel.
Note: For machining centres with synchronous spindle.
Observation: Pour centres d'usinage avec broche synchrone.



Tapping chucks for synchronisation for collets ISO 15488 (DIN 6499) ER-system

Mandrins de taraudage pour synchronisation pour pinces ISO 15488 (DIN 6499) système ER



Verwendung:
Für Bearbeitungszentren mit Synchronspindel.

Application:
For machining centres with synchronous spindle.

Application:
Pour centres d'usinage avec broche synchrone.

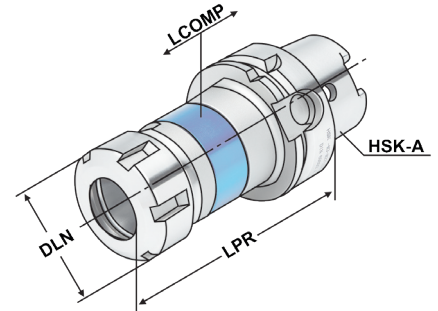

Bestell-Nr. Order no. Référence	HSK	DCONWS Spannbereich Capacity Capacité	Typ	LPR	DLN	LCOMP
A40.16.02.10	HSK-A 40	M3 – M12	426E ER 16	87	28	0,5
A40.16.02.13	HSK-A 40	M3 – M16	428E ER 20	93	34	0,5
A50.16.02.10	HSK-A 50	M3 – M12	426E ER 16	87	28	0,5
A50.16.02.13	HSK-A 50	M3 – M16	428E ER 20	88	34	0,5
A50.16.02.16	HSK-A 50	M3 – M20	430E ER 25	92	42	0,5
A50.16.02.20	HSK-A 50	M3 – M27	470E ER 32	116	50	0,5
A63.16.02.10 ¹	HSK-A 63	M3 – M12	426E ER 16 SW25	93	28	0,5
A63.16.02.10.M ²	HSK-A 63	M3 – M12	426E ER 16 Mini	93	22	0,5
A63.16.02.10.1.M ²	HSK-A 63	M3 – M12	426E ER 16 Mini	100	22	0,5
A63.16.02.13	HSK-A 63	M3 – M16	428E ER 20	94	34	0,5
A63.16.02.16	HSK-A 63	M3 – M20	430E ER 25	98	42	0,5
A63.16.02.20	HSK-A 63	M3 – M27	470E ER 32	108	50	0,5
A63.16.02.26	HSK-A 63	M3 – M33	472E ER 40	133,5	63	0,5
A80.16.02.13	HSK-A 80	M3 – M16	428E ER 20	100	34	0,5
A80.16.02.16	HSK-A 80	M3 – M20	430E ER 25	105	42	0,5
A80.16.02.20	HSK-A 80	M3 – M27	470E ER 32	110,5	50	0,5
A80.16.02.26	HSK-A 80	M3 – M33	472E ER 40	131	63	0,5
A100.16.02.10 ¹	HSK-A 100	M3 – M12	426E ER 16 SW25	96	28	0,5
A100.16.02.10.1.M ²	HSK-A 100	M3 – M12	426E ER 16 Mini	106	22	0,5
A100.16.02.13	HSK-A 100	M3 – M16	428E ER 20	97	34	0,5
A100.16.02.16	HSK-A 100	M3 – M20	430E ER 25	101	42	0,5
A100.16.02.20	HSK-A 100	M3 – M27	470E ER 32	110	50	0,5
A100.16.02.26	HSK-A 100	M3 – M33	472E ER 40	133	63	0,5

¹ Sechskantmutter
¹ Hexagonal clamping nut
¹ Écrous hexagonal

² Minimutter
² Mini nut
² Écrous mini

Lieferumfang: Mit gewuchteter Spannmutter
Delivery: With balanced clamping nut
Livraison: Avec écrou de serrage équilibré



Boring holders for drills with indexable inserts form E1
 Portes forets pour forets à plaquettes réversibles forme E1

(DIN 69893-1 | HSK-A)



Verwendung:
 Zur Aufnahme von allen nach DIN 6595 genormten Vollbohrern mit Zylinder-schaft.

Application:
 For all solid drills with cylindrical shank according to DIN 6595.

Application:
 Pour le serrage de forets à queue cylindrique suivant DIN 6595.

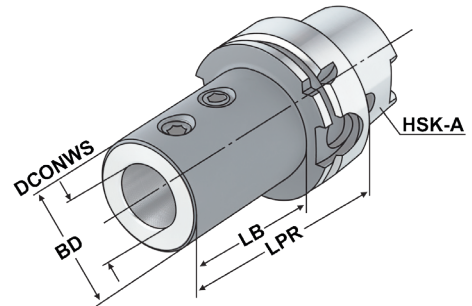

ISO 12164	Form A	$\leq 4\mu\text{m}$	G6.3 15.000 min ⁻¹	RFID Chip	ISO 9766	E1	H4
-----------	--------	---------------------	-------------------------------------	-----------	----------	----	----

Bestell-Nr. Order no. Référence	HSK	DCONWS	LPR	BD	LB
A63.51.20	HSK-A 63	20	80	40	54
A63.51.25	HSK-A 63	25	90	45	59
A63.51.32	HSK-A 63	32	90	52	63
A63.51.40	HSK-A 63	40	105	63	73

Lieferumfang: Mit Spannschrauben
Delivery: With clamping screws
Livraison: Avec vis de serrage



CNC-Drill chucks for clockwise and counter clockwise rotation
Mandrins de perçage CNC pour rotation gauche-droite

(DIN 69893-1 | HSK-A)

**Verwendung:**

Zur Aufnahme von Werkzeugen mit Zylinderschaft.

Application:

For mounting tools with straight shanks.

Application:

Pour le serrage d'outils avec queue cylindrique.

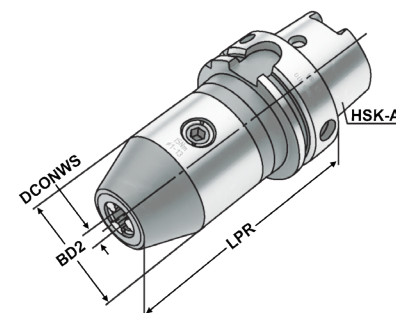

Bestell-Nr. Order no. Référence	HSK	DCONWS Spannbereich Capacity Capacité	LPR	BD2	DRVS
A32.15.08	HSK-A 32	0 – 8	90	36	4
A40.15.08	HSK-A 40	0 – 8	90	36	4
A40.15.13	HSK-A 40	1,0 – 13	121	50	6
A40.15.16	HSK-A 40	2,5 – 16	126	50	6
A50.15.08	HSK-A 50	0 – 8	90	36	4
A50.15.13	HSK-A 50	1,0 – 13	116	50	6
A50.15.16	HSK-A 50	2,5 – 16	116	50	6
A63.15.08	HSK-A 63	0 – 8	85	36	4
A63.15.13	HSK-A 63	1,0 – 13	104	50	6
A63.15.16	HSK-A 63	2,5 – 16	109	50	6
A80.15.13	HSK-A 80	1,0 – 13	109	50	6
A80.15.16	HSK-A 80	2,5 – 16	114	50	6
A100.15.13	HSK-A 100	1,0 – 13	107	50	6
A100.15.16	HSK-A 100	2,5 – 16	112	50	6

Hinweis: Hohe Präzision und Rundlaufgenauigkeit von $\leq 0,03$ mm. Sichere Spannung des Werkzeuges durch mechanische Spannkraftverstärkung. Kein selbständiges Lösen der Spannung während der Bearbeitung bei Links- oder Rechtslauf, sowie bei Spindelstop. Spannen und Lösen mit Sechskantschlüssel.

Note: High precision and accurate concentricity of ≤ 0.03 mm. Secure gripping of the tool through mechanical amplification of the clamping force. No automatic slackening of the clamping force while machining with either clockwise or counter clockwise rotation or on spindle stop. Clamping and releasing effected by means of an Allen wrench.

Observation: Précision élevée et exactitude de circularité de $\leq 0,03$ mm. Serrage sûr de l'outil grâce à l'amplification de la force de serrage. Pas de desserrage intempestif en cours d'usinage lors de la rotation la gauche ou la droite, de même qu'en cas d'arrêt de la broche. Serrage et desserrage en utilisant un clé sur à fourche.

Lieferumfang: Ohne Spannschlüssel
Delivery: Without wrench
Livraison: Sans clé de serrage



Boring bar blanks
Barres d'alésage

(DIN 69893-1 | HSK-A)

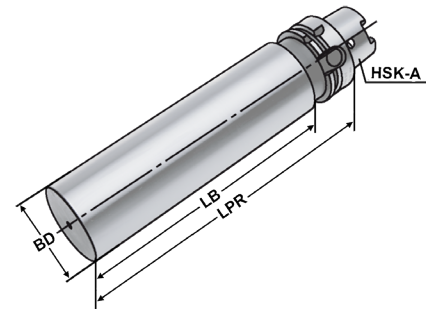

Verwendung:
Zur Herstellung von Sonderwerkzeugen.
Application:
For the manufacturing of special tools.
Application:
Pour la fabrication d'outils spéciaux.

ISO
12164Form
ARFID
Chip

Bestell-Nr.
Order no.
Référence

HSK

BD

LPR

LB

A32.17.25

HSK-A 32

32,5

100

65

A40.17.40

HSK-A 40

40,5

160

125

A50.17.50

HSK-A 50

50,5

200

158

A63.17.63

HSK-A 63

63,5

250

208

A63.17.80

HSK-A 63

80,0

250

208

A80.17.80

HSK-A 80

80,5

250

234

A100.17.97

HSK-A 100

97,5

250

234

Ausführung: Kegel und Bund gehärtet und geschliffen. Schaft weich zur weiteren Bearbeitung.
Version: Cone and flange hardened and grinded. Soft body for later processing.
Version: Cône et collerette durcis et rectifiés. Corps doux pour un usinage ultérieur.



5.49

Reducing adapter for adaption from HSK to PSC (ISO 12164 to ISO 26623-1) (DIN 69893-1 | HSK-A)
 Douille de réduction pour adaptation de HSK à PSC (ISO 12164 à ISO 26623-1)



Verwendung:
 Zur Adaption von HSK-A auf PSK
 (ISO 12164 auf ISO 26623-1)
Application:
 For adaption from HSK-A to PSC
 (ISO 12164 to ISO 26623-1)
Application:
 Pour adaptation de HSK-A à PSC
 (ISO 12164 à ISO 26623-1).

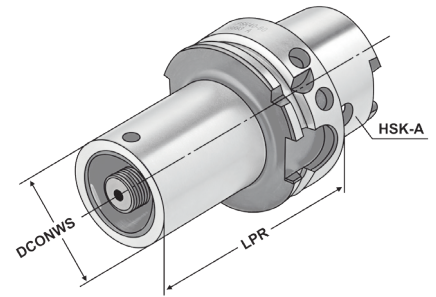

Bestell-Nr. Order no. Référence	HSK	Typ	DCONWS	LPR	TQX	THID
A63.09.C3	HSK-A 63	PSK C3	32	75	50	M12x1,5
A63.09.C4	HSK-A 63	PSK C4	40	80	50	M14x1,5
A63.09.C5	HSK-A 63	PSK C5	50	90	50	M16x1,5

Ausführung:

Adapter HSK / PSK mit Axialspannung. Innen und außen geschliffen. Das im PSK-Werkzeughalter für Kühlmittel-Rohre vorgesehene Innengewinde wird mit der im Adapter integrierten Zylinderkopfschraube verschraubt. Spannschraube durchbohrt, somit ist das System für Innenkühlung geeignet. Passend für Werkzeugaufnahmen mit Polygonschaft (PSC/PSK) ISO 26623-1.

Version:

Adapters HSK / PSK with axial clamping. Ground internally and externally. The internal thread provided for the coolant tube in the PSC toolholder is plugged with the socket-head screw incorporated in the adapter. The clamping screw incorporates a through hole, so the system is suitable for through-coolant feed. Suitable for tool arbor with polygonal shank (PSC) - ISO 26623-1.

Exécution:

Adaptateurs HSK / PSK Tension axiale. Intérieur et extérieur rectifiés. Le filetage intérieur prévu pour les conduits d'arrosage dans le porte-outils PSC est vissé à l'aide de la vis à tête cylindrique intégrée dans l'adaptateur. Système adapté à l'arrosage interne grâce à la vis de serrage percée. Pour la réception d'outils PSK ISO 26623-1.

Lieferumfang: Mit Spannschraube
Delivery: Clamping screw
Livraison: Avec vis de serrage



Hydraulic expansion chucks - slim design

(DIN 69893-1 | HSK-A)

Mandrins expansibles hydrauliques - type élané



Verwendung:

Zur Aufnahme von Werkzeugen mit Zylinderschaft. Besonders im Werkzeug- und Formenbau wo reduzierte Störkontur gefordert ist.

Application:

For mounting straight-shank tools. Especially in operations in toolmaking and mould making. Wherever reduced interference contours are required.

Application:

Pour le serrage d'outils avec queue cylindrique. Particulièrement dans la fabrication d'outils et de moules. Applications nécessitant un encombrement réduit.

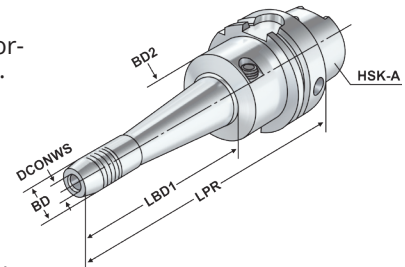

ISO 12164	Form A	$\leq 3\mu\text{m}$	G2.5 25.000 min ⁻¹	RFID Chip	13.04
-----------	--------	---------------------	-------------------------------	-----------	-------

Bestell-Nr. Order no. Référence	HSK	DCONWS	LPR	BD	BD2	LSCX	ADJRGA	LBD1	DRVS	THID
A63.HSL06.160	HSK-A 63	6	160	16	50	37	10	103	5	M6x1
A63.HSL08.160	HSK-A 63	8	160	18	50	37	10	103	5	M6x1
A63.HSL10.160	HSK-A 63	10	160	20	50	42	10	103	5	M8x1
A63.HSL12.160	HSK-A 63	12	160	22	50	47	10	104	5	M8x1

LSCX = Einspannlänge, max. ADJRGA = Verstellweg, max.
 LSCX = Clamping depth, max. ADJRGA = Length adjustment range, max.
 LSCX = Profondeur d'insertion, max. ADJRGA = Course de réglage, max.

Lieferumfang: Ohne Spanschlüssel
 Delivery: Without wrench
 Livraison: Sans clé de serrage

Gewuchtete Ausführung

Balanced type
 Type équilibré



Bestell-Nr. Order no. Référence	Abmessung Size Dimension
---------------------------------------	--------------------------------

Wuchten auf G 2,5 von vorgewuchteten Kemmler-Werkzeugen

Balancing at G 2.5 of pre-balanced Kemmler-tools
 Équilibrage G 2,5 d'outils Kemmler pré-équilibrés

W25 **Ohne Wuchtprotokoll**
 Without balancing report
 Sans protocole d'équilibrage

W25.2 **Mit Wuchtprotokoll**
 With balancing report
 Avec protocole d'équilibrage

Wuchten von nicht vorgewuchteten Werkzeugen
 Balancing of unbalanced tools
 Équilibrage d'outils non-équilibrés

W25.1 **Ohne Wuchtprotokoll**
 Without balancing report
 Sans protocole d'équilibrage



Hydraulic expansion chucks
Mandrins expansibles hydrauliques

(DIN 69893-1 | HSK-A)



Verwendung:

Zur Aufnahme von Werkzeugen mit Zylinderschaft nach DIN 1835 Form A+B+E und DIN 6535 Form HB+HE (größer Ø 20 mm nur mit Reduzierung).

Application:

For mounting straight-shank tools acc. DIN 1835 form A+B+E and DIN 6535 form HB+HE (larger than Ø 20 mm only with reduction sleeve).

Application:

Pour le serrage d'outils avec queue cylindrique suivant DIN 1835 forme A+B+E et DIN 6535 forme HB+HE (à partir de Ø 20 mm seulement avec réduction).

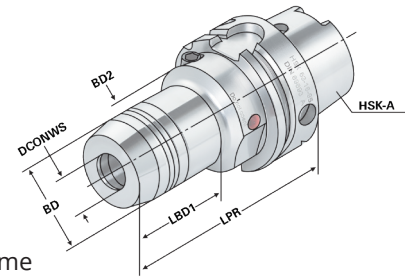

Bestell-Nr. Order no. Référence	HSK	DCONWS	LPR	BD	BD2	LSCX	ADJRGA	LBD1	DRVS	THID
A32.H06	HSK-A 32	6	80	26	33	37	10	31	5	M6x1
A32.H08	HSK-A 32	8	80	28	35	37	10	31	5	M6x1
A32.H10	HSK-A 32	10	85	30	37	42	10	36	5	M6x1
A32.H12	HSK-A 32	12	90	32	39	47	10	41	5	M6x1
A32.H14	HSK-A 32	14	95	34	26	47	10	60	5	M6x1
A32.H16	HSK-A 32	16	100	38	40	52	10	51	5	M8x1
A32.H20	HSK-A 32	20	100	42	42	52	10	65	5	M8x1
A40.H06	HSK-A 40	6	80	26	33,5	37	10	33	5	M6x1
A40.H08	HSK-A 40	8	80	28	33,5	37	10	33,5	5	M6x1
A40.H10	HSK-A 40	10	85	30	33,5	42	10	39	5	M6x1
A40.H12	HSK-A 40	12	90	32	33,5	47	10	44,5	5	M6x1
A40.H14	HSK-A 40	14	90	33,5	33,5	47	10	70	5	M6x1
A40.H16	HSK-A 40	16	90	38	50	52	10	38	5	M10x1
A40.H18	HSK-A 40	18	90	40	52	52	10	38	5	M10x1
A40.H20	HSK-A 40	20	90	42	54	52	10	38	5	M10x1
A50.H06	HSK-A 50	6	80	26	42	37	10	33	5	M6x1
A50.H08	HSK-A 50	8	80	28	42	37	10	33,5	5	M6x1
A50.H10	HSK-A 50	10	85	30	42	42	10	39	5	M8x1
A50.H12	HSK-A 50	12	90	32	42	47	10	44	5	M8x1
A50.H14	HSK-A 50	14	90	34	42	47	10	46	5	M10x1
A50.H16	HSK-A 50	16	95	38	42	52	10	51,5	5	M12x1
A50.H18	HSK-A 50	18	95	40	42	52	10	52	5	M12x1
A50.H20	HSK-A 50	20	100	42	42	52	10	74	5	M12x1
A50.H25	HSK-A 50	25	120	50	42	58	10	78	6	M12x1

LSCX = Einspannlänge, max.
LSCX = Clamping depth, max.
LSCX = Profondeur d'insertion, max.

ADJRGA = Verstellweg, max.
ADJRGA = Length adjustment range, max.
ADJRGA = Course de réglage, max.

Lieferumfang: Ohne Spannschlüssel
Delivery: Without wrench
Livraison: Sans clé de serrage



Hydraulic expansion chucks
Mandrins expansibles hydrauliques

(DIN 69893-1 | HSK-A)



Verwendung:

Zur Aufnahme von Werkzeugen mit Zylinderschaft nach DIN 1835 Form A+B+E und DIN 6535 Form HB+HE (größer Ø 20 mm nur mit Reduzierung).

Application:

For mounting straight-shank tools acc. DIN 1835 form A+B+E and DIN 6535 form HB+HE (larger than Ø 20 mm only with reduction sleeve).

Application:

Pour le serrage d'outils avec queue cylindrique suivant DIN 1835 forme A+B+E et DIN 6535 forme HB+HE (à partir de Ø 20 mm seulement avec réduction).

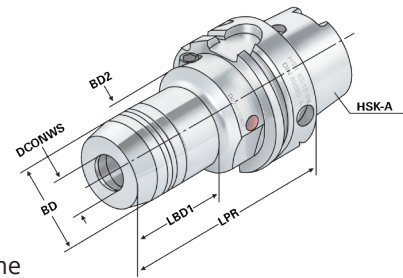

Bestell-Nr. Order no. Référence	HSK	DCONWS	LPR	BD	BD2	LSCX	ADJRGA	LBD1	DRVS	THID
A63.H06	HSK-A 63	6	80	26	50	37	10	33	5	M6x1
A63.H08	HSK-A 63	8	80	28	50	37	10	33,5	5	M6x1
A63.H10	HSK-A 63	10	85	30	50	42	10	39	5	M8x1
A63.H12	HSK-A 63	12	90	32	50	47	10	44,5	5	M8x1
A63.H14	HSK-A 63	14	90	34	50	47	10	46	5	M10x1
A63.H16	HSK-A 63	16	95	38	50	52	10	51,5	5	M12x1
A63.H18	HSK-A 63	18	95	40	50	52	10	52	5	M12x1
A63.H20	HSK-A 63	20	100	42	50	52	10	58	5	M10x1
A63.H25	HSK-A 63	25	120	50	50	58	10	94	6	M16x1
A63.H32	HSK-A 63	32	125	60	53	62	10	83	6	M16x1
A63.H06.1	HSK-A 63	6	150	26	50	37	10	103	5	M6x1
A63.H08.1	HSK-A 63	8	150	28	50	37	10	104	5	M6x1
A63.H10.1	HSK-A 63	10	150	30	50	42	10	104	5	M8x1
A63.H12.1	HSK-A 63	12	150	32	50	47	10	105	5	M8x1
A63.H14.1	HSK-A 63	14	150	34	50	47	10	105	5	M10x1
A63.H16.1	HSK-A 63	16	150	38	50	52	10	106,5	5	M12x1
A63.H18.1	HSK-A 63	18	150	40	50	52	10	107	5	M12x1
A63.H20.1	HSK-A 63	20	150	42	50	52	10	108	5	M10x1
A63.H25.1	HSK-A 63	25	150	50	50	58	10	124	6	M16x1
A63.H06.2	HSK-A 63	6	200	26	50	37	10	153	5	M6x1
A63.H08.2	HSK-A 63	8	200	28	50	37	10	154	5	M6x1
A63.H10.2	HSK-A 63	10	200	30	50	42	10	154	5	M8x1
A63.H12.2	HSK-A 63	12	200	32	50	47	10	155	5	M8x1
A63.H14.2	HSK-A 63	14	200	34	50	47	10	155	5	M10x1
A63.H16.2	HSK-A 63	16	200	38	50	52	10	156,5	5	M12x1
A63.H18.2	HSK-A 63	18	200	40	50	52	10	157	5	M12x1
A63.H20.2	HSK-A 63	20	200	42	50	52	10	158	5	M10x1
A63.H25.2	HSK-A 63	25	200	50	50	58	10	174	6	M16x1

LSCX = Einspannlänge, max.
LSCX = Clamping depth, max.
LSCX = Profondeur d'insertion, max.

ADJRGA = Verstellweg, max.
ADJRGA = Length adjustment range, max.
ADJRGA = Course de réglage, max.

Lieferumfang: Ohne Spannschlüssel
Delivery: Without wrench
Livraison: Sans clé de serrage



Hydraulic expansion chucks
Mandrins expansibles hydrauliques

(DIN 69893-1 | HSK-A)



Verwendung:
Zur Aufnahme von Werkzeugen mit Zylinderschaft nach DIN 1835 Form A+B+E und DIN 6535 Form HB+HE (größer Ø 20 mm nur mit Reduzierung).

Application:
For mounting straight-shank tools acc. DIN 1835 form A+B+E and DIN 6535 form HB+HE (larger than Ø 20 mm only with reduction sleeve).

Application:
Pour le serrage d'outils avec queue cylindrique suivant DIN 1835 forme A+B+E et DIN 6535 forme HB+HE (à partir de Ø 20 mm seulement avec réduction).

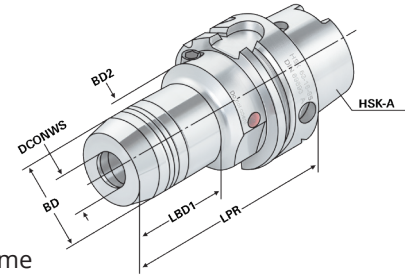

ISO 12164

Form A

$\leq 3\mu\text{m}$

G2.5
 25.000
 min⁻¹

RFID Chip

13.04

Bestell-Nr. Order no. Référence	HSK	DCONWS	LPR	BD	BD2	LSCX	ADJRG	LBD1	DRVS	THID
A80.H06	HSK-A 80	6	85	26	56	37	10	54	5	M6x1
A80.H08	HSK-A 80	8	85	28	56	37	10	53	5	M6x1
A80.H10	HSK-A 80	10	90	30	56	42	10	53	5	M8x1
A80.H12	HSK-A 80	12	95	32	56	47	10	52	5	M10x1
A80.H14	HSK-A 80	14	95	34	56	47	10	51	5	M10x1
A80.H16	HSK-A 80	16	100	38	56	52	10	50	5	M12x1
A80.H18	HSK-A 80	18	100	40	56	52	10	50	5	M12x1
A80.H20	HSK-A 80	20	105	42	56	52	10	49	5	M12x1
A80.H25	HSK-A 80	25	115	50	56	58	10	62	5	M16x1
A80.H32	HSK-A 80	32	120	60	56	62	10	26	5	M16x1
A100.H06	HSK-A 100	6	85	26	63	37	10	33	5	M6x1
A100.H08	HSK-A 100	8	85	28	63	37	10	33,5	5	M6x1
A100.H10	HSK-A 100	10	90	30	63	42	10	39	5	M8x1
A100.H12	HSK-A 100	12	95	32	63	47	10	44,5	5	M8x1
A100.H14	HSK-A 100	14	95	34	63	47	10	46	5	M8x1
A100.H16	HSK-A 100	16	100	38	63	52	10	53	5	M12x1
A100.H18	HSK-A 100	18	100	40	63	52	10	52	5	M12x1
A100.H20	HSK-A 100	20	105	42	63	52	10	51	5	M12x1
A100.H25	HSK-A 100	25	115	50	63	58	10	64	6	M12x1
A100.H32	HSK-A 100	32	120	60	63	62	10	61	6	M12x1
A100.H06.1	HSK-A 100	6	150	26	63	37	10	97	5	M6
A100.H08.1	HSK-A 100	8	150	28	63	37	10	98	5	M6
A100.H10.1	HSK-A 100	10	150	30	63	42	10	99	5	M8x1
A100.H12.1	HSK-A 100	12	150	32	63	47	10	99	5	M8x1
A100.H14.1	HSK-A 100	14	150	34	63	47	10	101	5	M8x1
A100.H16.1	HSK-A 100	16	150	38	63	52	10	101	5	M12x1
A100.H18.1	HSK-A 100	18	150	40	63	52	10	102	5	M12x1
A100.H20.1	HSK-A 100	20	150	42	63	52	10	101	5	M12x1
A100.H25.1	HSK-A 100	25	150	50	63	58	10	99	6	M12x1
A100.H32.1	HSK-A 100	32	150	60	63	62	10	100	6	M12x1

LSCX = Einspannlänge, max.
LSCX = Clamping depth, max.
LSCX = Profondeur d'insertion, max.

ADJRG = Verstellweg, max.
ADJRG = Length adjustment range, max.
ADJRG = Course de réglage, max.

Lieferumfang: Ohne Spannschlüssel
Delivery: Without wrench
Livraison: Sans clé de serrage





Verwendung:
Zur Aufnahme von Werkzeugen mit Zylinderschaft nach DIN 1835 Form A+B+E und DIN 6535 Form HB+HE (größer Ø 20 mm nur mit Reduzierung).

Application:
For mounting straight-shank tools acc. DIN 1835 form A+B+E and DIN 6535 form HB+HE (larger than Ø 20 mm only with reduction sleeve).

Application:
Pour le serrage d'outils avec queue cylindrique suivant DIN 1835 forme A+B+E et DIN 6535 forme HB+HE (à partir de Ø 20 mm seulement avec réduction).

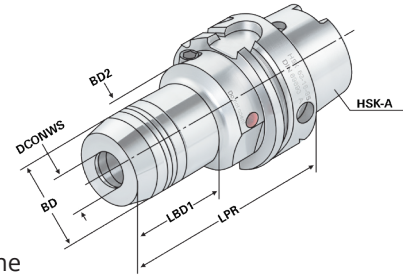

Bestell-Nr. Order no. Référence	HSK	DCONWS	LPR	BD	BD2	LSCX	ADJRGA	LBD1	DRVS	THID
A100.H06.2	HSK-A 100	6	200	26	50	37	10	56	5	M6x1
A100.H08.2	HSK-A 100	8	200	28	50	37	10	55,5	5	M6x1
A100.H10.2	HSK-A 100	10	200	30	50	42	10	55	5	M8x1
A100.H12.2	HSK-A 100	12	200	32	50	47	10	54,5	5	M10x1
A100.H14.2	HSK-A 100	14	200	34	50	47	10	53	5	M10x1
A100.H16.2	HSK-A 100	16	200	38	50	52	10	52,5	5	M12x1
A100.H18.2	HSK-A 100	18	200	40	50	52	10	52	5	M12x1
A100.H20.2	HSK-A 100	20	200	42	50	52	10	51	5	M12x1
A100.H25.2	HSK-A 100	25	200	50	50	58	10	-	6	M16x1
A100.H32.2	HSK-A 100	32	200	60	60	62	10	-	6	M16x1

LSCX = Einspannlänge, max. ADJRGA = Verstellweg, max.
LSCX = Clamping depth, max. ADJRGA = Length adjustment range, max.
LSCX = Profondeur d'insertion, max. ADJRGA = Course de réglage, max.

Lieferumfang: Ohne Spanschlüssel
Delivery: Without wrench
Livraison: Sans clé de serrage



Spannkraft-Prüfgerät für Hydrodehnspannfutter - Seite 12.59
Clamping force proofing instrument for hydraulic chucks - page 12.59
Appareil de contrôle des forces de serrage pour mandrin expansibles hydrauliques - page 12.59



Shrink chucks 4,5° for mounting of solid carbide and HSS-tool shanks

Mandrins de frettage 4,5° pour le serrage de queues d'outils carbures de type HM et HSS



Verwendung:
Zur Aufnahme von Werkzeugen mit Zylinderschaft.

Application:
For mounting straight-shank tools.

Application:
Pour le serrage d'outils avec queue cylindrique.

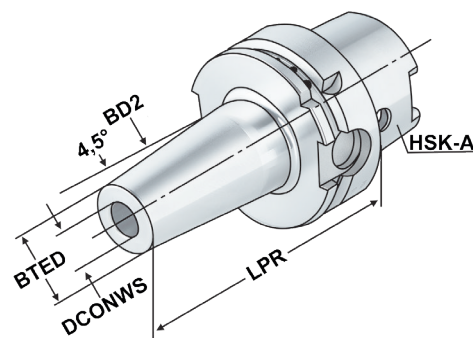

Bestell-Nr. Order no. Référence	HSK	DCONWS	TDCON	LPR	BTED	BD2	LSCN	LSCX	ADJRGA	THID
A32.70.03	HSK-A 32	3	h4	60	11	15	-	10	-	-
A32.70.04	HSK-A 32	4	h4	60	10	16	-	20	-	-
A32.70.05	HSK-A 32	5	h4	60	10	16	-	20	-	-
A32.70.06	HSK-A 32	6	h6	70	21	26	26	36	10	M5x0,8
A32.70.08	HSK-A 32	8	h6	70	21	26	26	36	10	M6x1
A32.70.10	HSK-A 32	10	h6	70	24	29	32	42	10	M8x1
A32.70.12	HSK-A 32	12	h6	90	24	29	37	47	10	M10x1
A32.70.14	HSK-A 32	14	h6	90	27	34	37	47	10	M10x1
A32.70.16	HSK-A 32	16	h6	90	27	34	40	50	10	M12x1
A32.70.20	HSK-A 32	20	h6	100	33	40	42	52	10	M12x1
A40.70.03	HSK-A 40	3	h4	80	11	15	-	10	-	-
A40.70.04	HSK-A 40	4	h4	80	14	22	-	20	-	-
A40.70.05	HSK-A 40	5	h4	80	16	22	-	20	-	-
A40.70.06	HSK-A 40	6	h6	80	21	27	26	36	10	M5x0,8
A40.70.08	HSK-A 40	8	h6	80	21	27	26	36	10	M6x1
A40.70.10	HSK-A 40	10	h6	80	24	32	32	42	10	M8x1
A40.70.12	HSK-A 40	12	h6	90	24	32	37	47	10	M10x1
A40.70.14	HSK-A 40	14	h6	90	27	34	37	47	10	M10x1
A40.70.16	HSK-A 40	16	h6	90	27	34	40	50	10	M12x1
A40.70.18	HSK-A 40	18	h6	95	33	42	40	50	10	M12x1
A40.70.20	HSK-A 40	20	h6	100	33	42	42	52	10	M16x1
A40.70.25	HSK-A 40	25	h6	100	44	51	48	58	10	M16x1

LSCX = Einspannlänge, max.
LSCX = Clamping depth, max.
LSCX = Profondeur d'insertion, max.

ADJRGA = Verstellweg, max.
ADJRGA = Length adjustment range, max.
ADJRGA = Course de réglage, max.

Für Ø 3, 4 und 5 mm nur Hartmetallschäfte verwenden!

For Ø 3, 4 and 5 mm only solid carbide tool shanks must be used!

Pour Ø 3, 4 et 5 mm il faut seulement utiliser de queues d'outils carbures de type HM!

Hinweis: Aufnahme für Induktiv-, Kontakt- und Heißluftschumpfergeräte geeignet.
Schafttoleranz bei Ø 3, 4 und 5 mm = h4, bei Ø 6 - Ø 32 mm = h6

Note: Toolholders suitable for induction-, contact- and hot air shrink units.
Ø 3, 4, 5 with h4-tolerance and Ø 6 - Ø 32 with h6-tolerance

Observation: Porte-outils convenables pour machines à fretter par induction, par contact, ou par air chaud.
Ø 3, 4, 5 avec h4-tolerance et Ø 6 - Ø 32 avec h6-tolerance

Shrink chucks 4,5° for mounting of solid carbide and HSS-tool shanks

Mandrins de frettage 4,5° pour le serrage de queues d'outils carbures de type HM et HSS



Verwendung:
Zur Aufnahme von Werkzeugen mit Zylinderschaft.

Application:
For mounting straight-shank tools.

Application:
Pour le serrage d'outils avec queue cylindrique.

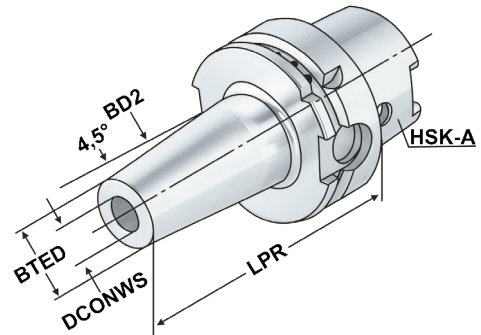

ISO 12164 Form A $\leq 3\mu\text{m}$ G2.5 25.000 min⁻¹ RFID Chip h6

Bestell-Nr. Order no. Référence	HSK	DCONWS	TDCON	LPR	BTED	BD2	LSCN	LSCX	ADJRGA	THID
A50.70.03	HSK-A 50	3	h4	80	11	15	-	18	-	-
A50.70.04	HSK-A 50	4	h4	80	14	22	-	20	-	-
A50.70.05	HSK-A 50	5	h4	80	16	22	-	20	-	-
A50.70.06	HSK-A 50	6	h6	80	21	27	26	36	10	M5x0,8
A50.70.08	HSK-A 50	8	h6	80	21	27	26	36	10	M6x1
A50.70.10	HSK-A 50	10	h6	85	24	32	32	42	10	M8x1
A50.70.12	HSK-A 50	12	h6	90	24	32	37	47	10	M10x1
A50.70.14	HSK-A 50	14	h6	90	27	34	37	47	10	M10x1
A50.70.16	HSK-A 50	16	h6	95	27	34	40	50	10	M12x1
A50.70.18	HSK-A 50	18	h6	95	33	42	40	50	10	M12x1
A50.70.20	HSK-A 50	20	h6	100	33	42	42	52	10	M16x1
A50.70.25	HSK-A 50	25	h6	115	44	53	48	58	10	M16x1
A50.70.32	HSK-A 50	32	h6	120	44	53	52	62	10	M16x1
A50.70.06.1	HSK-A 50	6	h6	120	21	27	26	36	10	M5x0,8
A50.70.08.1	HSK-A 50	8	h6	120	21	27	26	36	10	M6x1
A50.70.10.1	HSK-A 50	10	h6	120	24	32	32	42	10	M8x1
A50.70.12.1	HSK-A 50	12	h6	120	24	32	32	42	10	M10x1
A50.70.14.1	HSK-A 50	14	h6	120	27	34	37	47	10	M10x1
A50.70.16.1	HSK-A 50	16	h6	120	27	34	40	50	10	M12x1
A50.70.18.1	HSK-A 50	18	h6	120	33	42	40	50	10	M12x1
A50.70.20.1	HSK-A 50	20	h6	120	33	42	42	52	10	M16x1
A50.70.03.2	HSK-A 50	3	h4	160	11	15	-	10	-	-
A50.70.04.2	HSK-A 50	4	h4	160	14	22	15	20	5	-
A50.70.05.2	HSK-A 50	5	h4	160	16	22	15	20	5	-
A50.70.06.2	HSK-A 50	6	h6	160	21	27	26	36	10	M5x0,8
A50.70.08.2	HSK-A 50	8	h6	160	21	27	26	36	10	M6x1
A50.70.10.2	HSK-A 50	10	h6	160	24	32	32	42	10	M8x1
A50.70.12.2	HSK-A 50	12	h6	160	24	32	37	47	10	M10x1
A50.70.14.2	HSK-A 50	14	h6	160	27	34	37	47	10	M10x1
A50.70.16.2	HSK-A 50	16	h6	160	27	34	40	50	10	M12x1
A50.70.18.2	HSK-A 50	18	h6	160	33	42	40	50	10	M12x1
A50.70.20.2	HSK-A 50	20	h6	160	33	42	42	52	10	M16x1

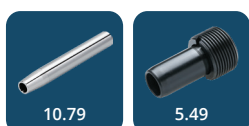

zum Spannen von HM und HSS Werkzeugschäften

(DIN 69893-1 | HSK-A)

Shrink chucks 4,5° for mounting of solid carbide and HSS-tool shanks

Mandrins de frettage 4,5° pour le serrage de queues d'outils carbures de type HM et HSS



Verwendung:

Zur Aufnahme von Werkzeugen mit Zylinderschaft.

Application:

For mounting straight-shank tools.

Application:

Pour le serrage d'outils avec queue cylindrique.

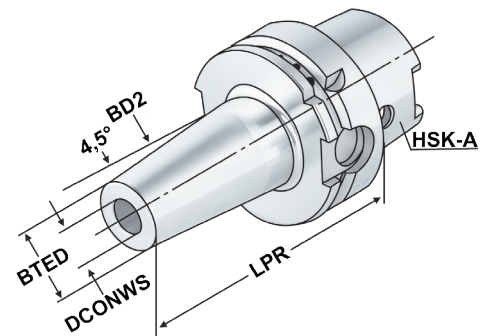

ISO 12164 Form A $\leq 3\mu\text{m}$ G2.5 25.000 min⁻¹ RFID Chip h6

Bestell-Nr. Order no. Référence	HSK	DCONWS	TDCON	LPR	BTED	BD2	LSCN	LSCX	ADJRGA	THID
A63.70.03	HSK-A 63	3	h4	80	11	15	9	-	-	-
A63.70.04	HSK-A 63	4	h4	80	14	22	9	-	-	-
A63.70.05	HSK-A 63	5	h4	80	16	22	10	-	-	-
A63.70.06	HSK-A 63	6	h6	80	21	27	22	36	10	M5x0,8
A63.70.08	HSK-A 63	8	h6	80	21	27	26	36	10	M6x1
A63.70.10	HSK-A 63	10	h6	85	24	32	31	41	10	M8x1
A63.70.12	HSK-A 63	12	h6	90	24	32	36	46	10	M10x1
A63.70.14	HSK-A 63	14	h6	90	27	34	36	46	10	M10x1
A63.70.16	HSK-A 63	16	h6	95	27	34	39	49	10	M12x1
A63.70.18	HSK-A 63	18	h6	95	33	42	39	49	10	M12x1
A63.70.20	HSK-A 63	20	h6	100	33	42	41	51	10	M16x1
A63.70.25	HSK-A 63	25	h6	115	44	53	47	57	10	M16x1
A63.70.32	HSK-A 63	32	h6	120	44	53	51	61	10	M16x1
A63.70.03.1	HSK-A 63	3	h4	120	11	15	9	-	-	-
A63.70.04.1	HSK-A 63	4	h4	120	14	22	9	-	-	-
A63.70.05.1	HSK-A 63	5	h4	120	16	22	10	-	-	-
A63.70.06.1	HSK-A 63	6	h6	120	21	27	22	36	10	M5x0,8
A63.70.08.1	HSK-A 63	8	h6	120	21	27	26	36	10	M6x1
A63.70.10.1	HSK-A 63	10	h6	120	24	32	31	41	10	M8x1
A63.70.12.1	HSK-A 63	12	h6	120	24	32	36	46	10	M10x1
A63.70.14.1	HSK-A 63	14	h6	120	27	34	36	46	10	M10x1
A63.70.16.1	HSK-A 63	16	h6	120	27	34	39	49	10	M12x1
A63.70.18.1	HSK-A 63	18	h6	120	33	42	39	49	10	M12x1
A63.70.20.1	HSK-A 63	20	h6	120	33	42	41	51	10	M16x1

Für Ø 3, 4 und 5 mm nur Hartmetallschäfte verwenden!

For Ø 3, 4 and 5 mm only solid carbide tool shanks must be used!

Pour Ø 3, 4 et 5 mm il faut seulement utiliser de queues d'outils carbures de type HM!

Hinweis: Aufnahme für Induktiv-, Kontakt- und Heißluftschumpfgeräte geeignet. Schafttoleranz bei Ø 3, 4 und 5 mm = h₄, bei Ø 6 - Ø 32 mm = h₆

Note: Toolholders suitable for induction-, contact- and hot air shrink units. Ø 3, 4, 5 with h₄-tolerance and Ø 6 - Ø 32 with h₆-tolerance

Observation: Porte-outils convenables pour machines à fretter par induction, par contact, ou par air chaud. Ø 3, 4, 5 avec h₄-tolerance et Ø 6 - Ø 32 avec h₆-tolerance

LSCX = Einspannlänge, max.
LSCX = Clamping depth, max.
LSCX = Profondeur d'insertion, max.

ADJRGA = Verstellweg, max.
ADJRGA = Length adjustment range, max.
ADJRGA = Course de réglage, max.

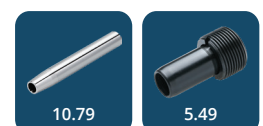

Shrink chucks 4,5° for mounting of solid carbide and HSS-tool shanks

Mandrins de frettage 4,5° pour le serrage de queues d'outils carbures de type HM et HSS



Verwendung:
Zur Aufnahme von Werkzeugen mit Zylinderschaft.

Application:
For mounting straight-shank tools.

Application:
Pour le serrage d'outils avec queue cylindrique.

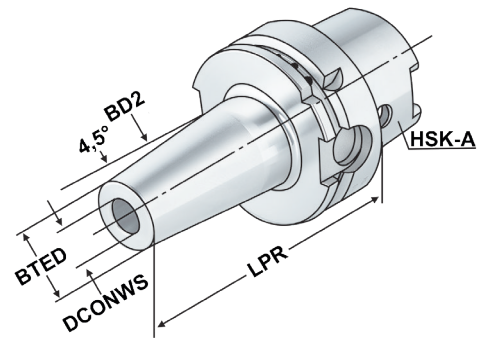

Bestell-Nr. Order no. Référence	HSK	DCONWS	TDCON	LPR	BTED	BD2	LSCN	LSCX	ADJRGA	THID
A63.70.03.2	HSK-A 63	3	h4	160	11	15	9	-	-	-
A63.70.04.2	HSK-A 63	4	h4	160	14	22	9	-	-	-
A63.70.05.2	HSK-A 63	5	h4	160	16	22	10	-	-	-
A63.70.06.2	HSK-A 63	6	h6	160	21	27	22	36	10	M5x0,8
A63.70.08.2	HSK-A 63	8	h6	160	21	27	26	36	10	M6x1
A63.70.10.2	HSK-A 63	10	h6	160	24	32	31	41	10	M8x1
A63.70.12.2	HSK-A 63	12	h6	160	24	32	36	46	10	M10x1
A63.70.14.2	HSK-A 63	14	h6	160	27	34	36	46	10	M10x1
A63.70.16.2	HSK-A 63	16	h6	160	27	34	39	49	10	M12x1
A63.70.18.2	HSK-A 63	18	h6	160	33	42	39	49	10	M12x1
A63.70.20.2	HSK-A 63	20	h6	160	33	42	41	51	10	M16x1
A63.70.25.2	HSK-A 63	25	h6	160	44	53	47	57	10	M16x1
A63.70.32.2	HSK-A 63	32	h6	160	44	53	51	61	10	M16x1
A63.70.06.3	HSK-A 63	6	h6	200	21	27	22	36	10	M5x0,8
A63.70.08.3	HSK-A 63	8	h6	200	21	27	26	36	10	M6x1
A63.70.10.3	HSK-A 63	10	h6	200	24	32	31	41	10	M8x1
A63.70.12.3	HSK-A 63	12	h6	200	24	32	36	46	10	M10x1
A63.70.14.3	HSK-A 63	14	h6	200	27	34	36	46	10	M10x1
A63.70.16.3	HSK-A 63	16	h6	200	27	34	39	49	10	M12x1
A63.70.18.3	HSK-A 63	18	h6	200	33	42	39	49	10	M12x1
A63.70.20.3	HSK-A 63	20	h6	200	33	42	41	51	10	M16x1
A63.70.25.3	HSK-A 63	25	h6	200	44	53	47	57	10	M16x1
A63.70.32.3	HSK-A 63	32	h6	200	44	53	51	61	10	M16x1

Für Ø 3, 4 und 5 mm nur Hartmetallschäfte verwenden!

For Ø 3, 4 and 5 mm only solid carbide tool shanks must be used!

Pour Ø 3, 4 et 5 mm il faut seulement utiliser de queues d'outils carbures de type HM!

Hinweis: Aufnahme für Induktiv-, Kontakt- und Heißluftschumpfergeräte geeignet. Schafttoleranz bei Ø 3, 4 und 5 mm = h₄, bei Ø 6 – Ø 32 mm = h₆

Note: Toolholders suitable for induction-, contact- and hot air shrink units. Ø 3, 4, 5 with h₄-tolerance and Ø 6 – Ø 32 with h₆-tolerance

Observation: Porte-outils convenables pour machines à fretter par induction, par contact, ou par air chaud. Ø 3, 4, 5 avec h₄-tolerance et Ø 6 – Ø 32 avec h₆-tolerance

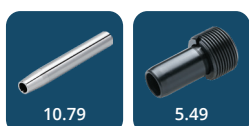

LSCX = Einspannlänge, max.
LSCX = Clamping depth, max.
LSCX = Profondeur d'insertion, max.

ADJRGA = Verstellweg, max.
ADJRGA = Length adjustment range, max.
ADJRGA = Course de réglage, max.

zum Spannen von HM und HSS Werkzeugschäften

(DIN 69893-1 | HSK-A)

Shrink chucks 4,5° for mounting of solid carbide and HSS-tool shanks

Mandrins de frettage 4,5° pour le serrage de queues d'outils carbures de type HM et HSS



Verwendung:
Zur Aufnahme von Werkzeugen mit Zylinderschaft.

Application:
For mounting straight-shank tools.

Application:
Pour le serrage d'outils avec queue cylindrique.

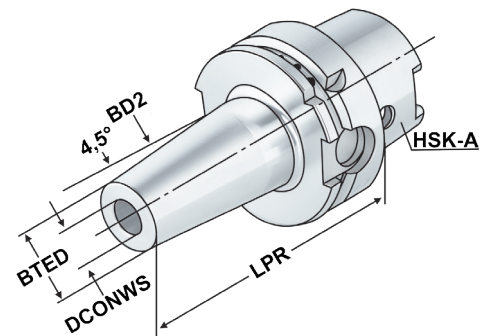

Bestell-Nr. Order no. Référence	HSK	DCONWS	TDCON	LPR	BTED	BD2	LSCN	LSCX	ADJRGA	THID
A80.70.04	HSK-A 80	4	h4	80	14	22	-	10	-	-
A80.70.06	HSK-A 80	6	h6	85	21	27	26	36	10	M5x0,8
A80.70.08	HSK-A 80	8	h6	85	21	27	26	36	10	M6x1
A80.70.10	HSK-A 80	10	h6	90	24	32	32	42	10	M8x1
A80.70.12	HSK-A 80	12	h6	95	24	32	37	47	10	M10x1
A80.70.14	HSK-A 80	14	h6	95	27	34	37	47	10	M10x1
A80.70.16	HSK-A 80	16	h6	100	27	34	40	50	10	M12x1
A80.70.18	HSK-A 80	18	h6	100	33	42	40	50	10	M12x1
A80.70.20	HSK-A 80	20	h6	105	33	42	42	52	10	M16x1
A80.70.25	HSK-A 80	25	h6	115	44	53	48	58	10	M16x1
A80.70.32	HSK-A 80	32	h6	120	44	53	52	62	10	M16x1
A80.70.06.1	HSK-A 80	6	h6	120	21	27	26	36	10	M5x0,8
A80.70.08.1	HSK-A 80	8	h6	120	21	27	26	36	10	M6x1
A80.70.10.1	HSK-A 80	10	h6	120	24	32	32	42	10	M8x1
A80.70.12.1	HSK-A 80	12	h6	120	24	32	37	47	10	M10x1
A80.70.14.1	HSK-A 80	14	h6	120	27	34	37	47	10	M10x1
A80.70.06.2	HSK-A 80	6	h6	160	21	27	26	36	10	M5x0,8
A80.70.08.2	HSK-A 80	8	h6	160	21	27	26	36	10	M6x1
A80.70.10.2	HSK-A 80	10	h6	160	24	32	32	42	10	M8x1
A80.70.12.2	HSK-A 80	12	h6	160	24	32	37	47	10	M10x1
A80.70.14.2	HSK-A 80	14	h6	160	27	34	37	47	10	M10x1
A80.70.16.2	HSK-A 80	16	h6	160	27	34	40	50	10	M12x1
A80.70.18.2	HSK-A 80	18	h6	160	33	42	40	50	10	M12x1
A80.70.20.2	HSK-A 80	20	h6	160	33	42	42	52	10	M16x1
A80.70.25.2	HSK-A 80	25	h6	160	44	53	48	58	10	M16x1

LSCX = Einspannlänge, max. ADJRGA = Verstellweg, max.
 LSCX = Clamping depth, max. ADJRGA = Length adjustment range, max.
 LSCX = Profondeur d'insertion, max. ADJRGA = Course de réglage, max.

Für Ø 3, 4 und 5 mm nur Hartmetallschäfte verwenden!
 For Ø 3, 4 and 5 mm only solid carbide tool shanks must be used!
 Pour Ø 3, 4 et 5 mm il faut seulement utiliser de queues d'outils carbures de type HM!

Hinweis: Aufnahme für Induktiv-, Kontakt- und Heißluftschumpfergeräte geeignet.
 Schafttoleranz bei Ø 3, 4 und 5 mm = h₄, bei Ø 6 - Ø 32 mm = h₆

Note: Toolholders suitable for induction-, contact- and hot air shrink units.
 Ø 3, 4, 5 with h₄-tolerance and Ø 6 - Ø 32 with h₆-tolerance

Observation: Porte-outils convenables pour machines à fretter par induction,
 par contact, ou par air chaud.
 Ø 3, 4, 5 avec h₄-tolerance et Ø 6 - Ø 32 avec h₆-tolerance

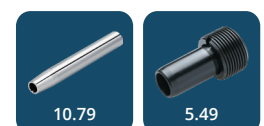

zum Spannen von HM und HSS Werkzeugschäften

(DIN 69893-1 | HSK-A)

Shrink chucks 4,5° for mounting of solid carbide and HSS-tool shanks

Mandrins de frettage 4,5° pour le serrage de queues d'outils carbures de type HM et HSS



Verwendung:
Zur Aufnahme von Werkzeugen mit Zylinderschaft.

Application:
For mounting straight-shank tools.

Application:
Pour le serrage d'outils avec queue cylindrique.

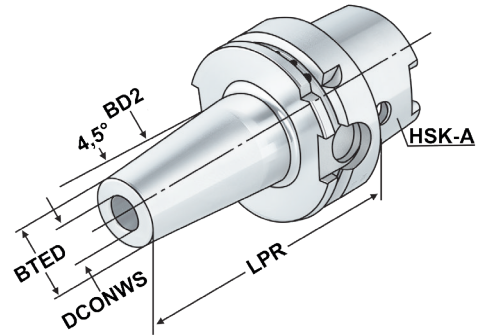

ISO 12164 Form A $\leq 3\mu\text{m}$ G2.5 25.000 min⁻¹ RFID Chip h6

Bestell-Nr. Order no. Référence	HSK	DCONWS	TDCON	LPR	BTED	BD2	LSCN	LSCX	ADJRG	THID
A100.70.04	HSK-A 100	4	h4	85	14	22	8	-	-	-
A100.70.05	HSK-A 100	5	h4	85	16	22	10	-	-	-
A100.70.06	HSK-A 100	6	h6	85	21	27	22	36	10	M5x0,8
A100.70.08	HSK-A 100	8	h6	85	21	27	26	36	10	M6x1
A100.70.10	HSK-A 100	10	h6	90	24	32	31	41	10	M8x1
A100.70.12	HSK-A 100	12	h6	95	24	32	36	46	10	M10x1
A100.70.14	HSK-A 100	14	h6	95	27	34	36	46	10	M10x1
A100.70.16	HSK-A 100	16	h6	100	27	34	39	49	10	M12x1
A100.70.18	HSK-A 100	18	h6	100	33	42	39	49	10	M12x1
A100.70.20	HSK-A 100	20	h6	105	33	42	41	51	10	M16x1
A100.70.25	HSK-A 100	25	h6	120	44	53	47	57	10	M16x1
A100.70.32	HSK-A 100	32	h6	120	44	53	51	61	10	M16x1
A100.70.40	HSK-A 100	40	h6	150	78	90	80	90	10	M16x1
A100.70.50	HSK-A 100	50	h6	150	78	90	80	90	10	M16x1
A100.70.06.1	HSK-A 100	6	h6	120	21	27	22	36	10	M5x0,8
A100.70.08.1	HSK-A 100	8	h6	120	21	27	26	36	10	M6x1
A100.70.10.1	HSK-A 100	10	h6	120	24	32	31	41	10	M8x1
A100.70.12.1	HSK-A 100	12	h6	120	24	32	36	46	10	M10x1
A100.70.14.1	HSK-A 100	14	h6	120	27	34	36	46	10	M10x1
A100.70.16.1	HSK-A 100	16	h6	120	27	34	39	49	10	M12x1
A100.70.18.1	HSK-A 100	18	h6	120	33	42	39	49	10	M12x1
A100.70.20.1	HSK-A 100	20	h6	120	33	42	41	51	10	M16x1
A100.70.06.2	HSK-A 100	6	h6	160	21	27	22	36	10	M5x0,8
A100.70.08.2	HSK-A 100	8	h6	160	21	27	26	36	10	M6x1
A100.70.10.2	HSK-A 100	10	h6	160	24	32	31	41	10	M8x1
A100.70.12.2	HSK-A 100	12	h6	160	24	32	36	46	10	M10x1
A100.70.14.2	HSK-A 100	14	h6	160	27	34	36	46	10	M10x1
A100.70.16.2	HSK-A 100	16	h6	160	27	34	39	49	10	M12x1
A100.70.18.2	HSK-A 100	18	h6	160	33	42	39	49	10	M12x1
A100.70.20.2	HSK-A 100	20	h6	160	33	42	41	51	10	M16x1
A100.70.25.2	HSK-A 100	25	h6	160	44	53	47	57	10	M16x1
A100.70.32.2	HSK-A 100	32	h6	160	44	53	51	61	10	M16x1

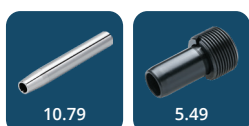

Shrink chucks 4,5° for mounting of solid carbide and HSS-tool shanks

Mandrins de frettage 4,5° pour le serrage de queues d'outils carbures de type HM et HSS



Verwendung:

Zur Aufnahme von Werkzeugen mit Zylinderschaft.

Application:

For mounting straight-shank tools.

Application:

Pour le serrage d'outils avec queue cylindrique.

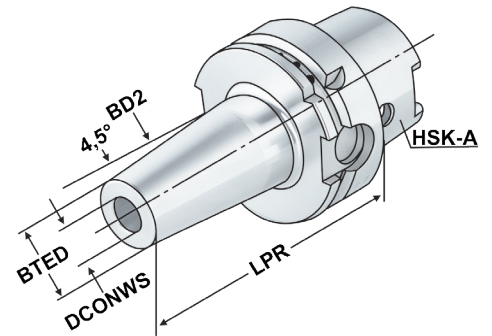

ISO 12164 Form A $\leq 3\mu\text{m}$ G2.5 25.000 min⁻¹ RFID Chip h6

Bestell-Nr. Order no. Référence	HSK	DCONWS	TDCON	LPR	BTED	BD2	LSCN	LSCX	ADJRGA	THID
A100.70.06.3	HSK-A 100	6	h6	200	21	27	22	36	10	M5x0,8
A100.70.08.3	HSK-A 100	8	h6	200	21	27	26	36	10	M6x1
A100.70.10.3	HSK-A 100	10	h6	200	24	32	31	41	10	M8x1
A100.70.12.3	HSK-A 100	12	h6	200	24	32	36	46	10	M10x1
A100.70.14.3	HSK-A 100	14	h6	200	27	34	36	46	10	M10x1
A100.70.16.3	HSK-A 100	16	h6	200	27	34	39	49	10	M12x1
A100.70.18.3	HSK-A 100	18	h6	200	33	42	39	49	10	M12x1
A100.70.20.3	HSK-A 100	20	h6	200	33	42	41	51	10	M16x1
A100.70.25.3	HSK-A 100	25	h6	200	44	53	47	57	10	M16x1
A100.70.32.3	HSK-A 100	32	h6	200	44	53	51	61	10	M16x1
A100.70.06.4	HSK-A 100	6	h6	250	21	27	22	36	10	M5x0,8
A100.70.08.4	HSK-A 100	8	h6	250	21	27	26	36	10	M6x1
A100.70.10.4	HSK-A 100	10	h6	250	24	32	31	41	10	M8x1
A100.70.12.4	HSK-A 100	12	h6	250	24	32	36	46	10	M10x1
A100.70.14.4	HSK-A 100	14	h6	250	27	34	36	46	10	M10x1
A100.70.16.4	HSK-A 100	16	h6	250	27	34	39	49	10	M12x1

LSCX = Einspannlänge, max. ADJRGA = Verstellweg, max.
 LSCX = Clamping depth, max. ADJRGA = Length adjustment range, max.
 LSCX = Profondeur d'insertion, max. ADJRGA = Course de réglage, max.

Für Ø 3, 4 und 5 mm nur Hartmetallschäfte verwenden!
 For Ø 3, 4 and 5 mm only solid carbide tool shanks must be used!
 Pour Ø 3, 4 et 5 mm il faut seulement utiliser de queues d'outils carbures de type HM!

Hinweis: Aufnahme für Induktiv-, Kontakt- und Heißluftschrimpferäte geeignet.
 Schafttoleranz bei Ø 3, 4 und 5 mm = h₄, bei Ø 6 - Ø 32 mm = h₆

Note: Toolholders suitable for induction-, contact- and hot air shrink units.
 Ø 3, 4, 5 with h₄-tolerance and Ø 6 - Ø 32 with h₆-tolerance

Observation: Porte-outils convenables pour machines à fretter par induction,
 par contact, ou par air chaud.
 Ø 3, 4, 5 avec h₄-tolerance et Ø 6 - Ø 32 avec h₆-tolerance

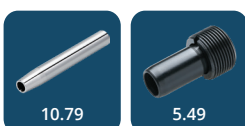

Shrink chucks 4,5° for mounting of solid carbide and HSS-tool shanks

Mandrins de frettage 4,5° pour le serrage de queues d'outils carbures de type HM et HSS



Verwendung:
Zur Aufnahme von Werkzeugen mit Zylinderschaft.

Application:
For mounting straight-shank tools.

Application:
Pour le serrage d'outils avec queue cylindrique.

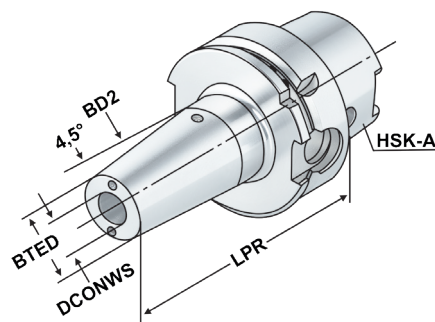

Bestell-Nr. Order no. Référence	HSK	DCONWS	TDCON	LPR	BTED	BD2	LSCN	LSCX	ADJRGA	THID
A63.70.03.K	HSK-A 63	3	h4	80	11	15	9	-	-	-
A63.70.04.K	HSK-A 63	4	h4	80	14	22	9	-	-	-
A63.70.05.K	HSK-A 63	5	h6	80	16	22	10	-	-	-
A63.70.06.K	HSK-A 63	6	h6	80	21	27	22	36	10	M5x0,8
A63.70.08.K	HSK-A 63	8	h6	80	21	27	26	36	10	M6x1
A63.70.10.K	HSK-A 63	10	h6	85	24	32	31	41	10	M8x1
A63.70.12.K	HSK-A 63	12	h6	90	24	32	36	46	10	M10x1
A63.70.14.K	HSK-A 63	14	h6	90	27	34	36	46	10	M10x1
A63.70.16.K	HSK-A 63	16	h6	95	27	34	39	49	10	M12x1
A63.70.18.K	HSK-A 63	18	h6	95	33	42	39	49	10	M12x1
A63.70.20.K	HSK-A 63	20	h6	100	33	42	41	51	10	M16x1
A63.70.25.K	HSK-A 63	25	h6	115	44	53	48	58	10	M16x1
A63.70.32.K	HSK-A 63	32	h6	120	44	53	51	61	10	M16x1
A63.70.03.1.K	HSK-A 63	3	h6	120	11	15	-	-	-	-
A63.70.04.1.K	HSK-A 63	4	h6	120	14	22	-	-	-	-
A63.70.05.1.K	HSK-A 63	5	h6	120	16	22	-	-	-	-
A63.70.06.1.K	HSK-A 63	6	h6	120	21	27	22	36	10	M5x0,8
A63.70.08.1.K	HSK-A 63	8	h6	120	21	27	26	36	10	M6x1
A63.70.10.1.K	HSK-A 63	10	h6	120	24	32	31	41	10	M8x1
A63.70.12.1.K	HSK-A 63	12	h6	120	24	32	36	46	10	M10x1
A63.70.14.1.K	HSK-A 63	14	h6	120	27	34	36	46	10	M10x1
A63.70.16.1.K	HSK-A 63	16	h6	120	27	34	39	49	10	M12x1
A63.70.18.1.K	HSK-A 63	18	h6	120	33	42	39	49	10	M12x1
A63.70.20.1.K	HSK-A 63	20	h6	120	33	42	41	51	10	M16x1

LSCX = Einspannlänge, max.
LSCX = Clamping depth, max.
LSCX = Profondeur d'insertion, max.

ADJRGA = Verstellweg, max.
ADJRGA = Length adjusting range, max.
ADJRGA = Course de réglage, max.

Für Ø 3, 4 und 5 mm nur Hartmetallschäfte verwenden!

For Ø 3, 4 and 5 mm only solid carbide tool shanks must be used!

Pour Ø 3, 4 et 5 mm il faut seulement utiliser de queues d'outils carbures de type HM!

Hinweis: Aufnahme für Induktiv-, Kontakt- und Heißluftschumpfergeräte geeignet.
Schafttoleranz bei Ø 3, 4 und 5 mm = h₄, bei Ø 6 - Ø 32 mm = h₆

Note: Toolholders suitable for induction-, contact- and hot air shrink units.
Ø 3, 4, 5 with h₄-tolerance and Ø 6 - Ø 32 with h₆-tolerance

Observation: Porte-outils convenables pour machines à fretter par induction, par contact, ou par air chaud.
Ø 3, 4, 5 avec h₄-tolerance et Ø 6 - Ø 32 avec h₆-tolerance

Shrink chucks 4,5° for mounting of solid carbide and HSS-tool shanks

Mandrins de frettage 4,5° pour le serrage de queues d'outils carbures de type HM et HSS



Verwendung:

Zur Aufnahme von Werkzeugen mit Zylinderschaft.

Application:

For mounting straight-shank tools.

Application:

Pour le serrage d'outils avec queue cylindrique.

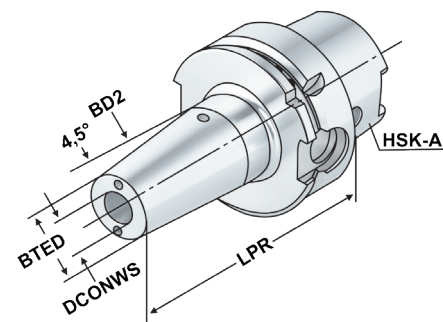

Bestell-Nr. Order no. Référence	HSK	DCONWS	TDCON	LPR	BTED	BD2	LSCN	LSCX	ADJRGA	THID
A63.70.06.2.K	HSK-A 63	6	h6	160	21	27	26	36	10	M5x0,8
A63.70.08.2.K	HSK-A 63	8	h6	160	21	27	26	36	10	M6x1
A63.70.10.2.K	HSK-A 63	10	h6	160	24	32	41	42	10	M8x1
A63.70.12.2.K	HSK-A 63	12	h6	160	24	32	37	47	10	M10x1
A63.70.14.2.K	HSK-A 63	14	h6	160	27	34	37	47	10	M10x1
A63.70.16.2.K	HSK-A 63	16	h6	160	27	34	40	50	10	M12x1
A63.70.18.2.K	HSK-A 63	18	h6	160	33	42	40	50	10	M12x1
A63.70.20.2.K	HSK-A 63	20	h6	160	33	42	42	52	10	M16x1
A63.70.25.2.K	HSK-A 63	25	h6	160	44	53	48	58	10	M16x1
A63.70.32.2.K	HSK-A 63	32	h6	160	44	53	51	61	10	M16x1
A100.70.05.K	HSK-A 100	5	h4	80	16	22	-	-	-	-
A100.70.06.K	HSK-A 100	6	h6	80	21	27	26	36	10	M5x0,8
A100.70.08.K	HSK-A 100	8	h6	80	21	27	26	36	10	M6x1
A100.70.10.K	HSK-A 100	10	h6	85	24	32	41	42	10	M8x1
A100.70.12.K	HSK-A 100	12	h6	90	24	32	46	47	10	M10x1
A100.70.14.K	HSK-A 100	14	h6	90	27	34	46	47	10	M10x1
A100.70.16.K	HSK-A 100	16	h6	95	27	34	40	50	10	M12x1
A100.70.18.K	HSK-A 100	18	h6	95	33	42	40	50	10	M12x1
A100.70.20.K	HSK-A 100	20	h6	100	33	42	42	52	10	M16x1
A100.70.25.K	HSK-A 100	25	h6	120	44	53	48	58	10	M16x1
A100.70.32.K	HSK-A 100	32	h6	120	44	53	51	61	10	M16x1
A100.70.05.1.K	HSK-A 100	5	h4	120	16	22	10	-	-	-
A100.70.06.1.K	HSK-A 100	6	h6	120	21	27	26	36	10	M5x0,8
A100.70.08.1.K	HSK-A 100	8	h6	120	21	27	26	36	10	M6x1
A100.70.10.1.K	HSK-A 100	10	h6	120	24	32	42	42	10	M8x1
A100.70.12.1.K	HSK-A 100	12	h6	120	24	32	37	47	10	M10x1
A100.70.14.1.K	HSK-A 100	14	h6	120	27	34	37	47	10	M10x1
A100.70.16.1.K	HSK-A 100	16	h6	120	27	34	40	50	10	M12x1
A100.70.18.1.K	HSK-A 100	18	h6	120	33	42	40	50	10	M12x1
A100.70.20.1.K	HSK-A 100	20	h6	120	33	42	42	52	10	M16x1
A100.70.25.1.K	HSK-A 100	25	h6	120	44	53	48	58	10	M16x1
A100.70.32.1.K	HSK-A 100	32	h6	120	44	53	51	61	10	M16x1

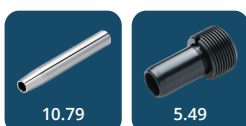

Shrink chucks 3° for mounting of solid carbide and HSS-tool shanks - slim

Mandrins de frettage 3° pour le serrage de queues d'outils carbures de type HM et HSS - élané



Verwendung:
Zur Aufnahme von Werkzeugen mit Zylinderschaft.

Application:
For mounting straight-shank tools.

Application:
Pour le serrage d'outils avec queue cylindrique.

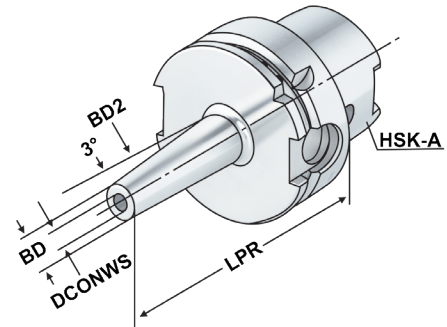

Bestell-Nr. Order no. Référence	HSK	DCONWS	TDCON	LPR	BTED	BD2	LSCN	LSCX	ADJRGA	THID
A63.72.03	HSK-A 63	3	h4	80	9	15,5	6	-	-	-
A63.72.04	HSK-A 63	4	h4	80	10	16,5	8	-	-	-
A63.72.05	HSK-A 63	5	h4	80	11	17,5	10	-	-	-
A63.72.06	HSK-A 63	6	h6	80	12	18,5	22	36	10	M5x0,8
A63.72.08	HSK-A 63	8	h6	80	14	20,5	26	36	10	M6x1
A63.72.10	HSK-A 63	10	h6	80	16	22,5	31	41	10	M8x1
A63.72.12	HSK-A 63	12	h6	80	18	24,5	36	46	10	M10x1
A63.72.03.1	HSK-A 63	3	h4	120	9	19,5	6	-	-	-
A63.72.04.1	HSK-A 63	4	h4	120	10	20,5	8	-	-	-
A63.72.05.1	HSK-A 63	5	h4	120	11	21,5	10	-	-	-
A63.72.06.1	HSK-A 63	6	h6	120	12	22,5	22	36	10	M5x0,8
A63.72.08.1	HSK-A 63	8	h6	120	14	24,5	26	36	10	M6x1
A63.72.10.1	HSK-A 63	10	h6	120	16	26,5	31	41	10	M8x1
A63.72.12.1	HSK-A 63	12	h6	120	18	28,5	36	46	10	M10x1
A63.72.04.2	HSK-A 63	4	h4	160	10	24	8	-	-	-
A63.72.05.2	HSK-A 63	5	h4	160	11	25	10	-	-	-
A63.72.06.2	HSK-A 63	6	h6	160	12	26,5	22	36	10	M5x0,8
A63.72.08.2	HSK-A 63	8	h6	160	14	28,5	26	36	10	M6x1
A63.72.10.2	HSK-A 63	10	h6	160	16	30,5	31	41	10	M8x1
A63.72.12.2	HSK-A 63	12	h6	160	18	32,5	36	46	10	M10x1

LSCX = Einspannlänge, max. ADJRGA = Verstellweg, max.
 LSCX = Clamping depth, max. ADJRGA = Length adjustment range, max.
 LSCX = Profondeur d'insertion, max. ADJRGA = Course de réglage, max.

Ausführung: schlanke Bauform (reduzierte Störkontur)
Version: slim design (reduced interference contour)
Version: Modèle très étroit (encombrement réduit)

Für Ø 3, 4 und 5 mm nur Hartmetallschäfte verwenden!
 For Ø 3, 4 and 5 mm only solid carbide tool shanks must be used!
 Pour Ø 3, 4 et 5 mm il faut seulement utiliser de queues d'outils carbures de type HM!

Hinweis: Aufnahmen für Induktiv-, Kontakt- und Heißluftschumpfergeräte geeignet.
 Schafttoleranz bei Ø 3, 4 und 5 mm = h₄, bei Ø 6 - Ø 32 mm = h₆

Note: Toolholders suitable for induction-, contact- and hot air shrink units.
 Ø 3, 4, 5 with h₄-tolerance and Ø 6 - Ø 32 with h₆-tolerance

Observation: Porte-outils convenables pour machines à fretter par induction, par contact, ou par air chaud.
 Ø 3, 4, 5 avec h₄-tolerance et Ø 6 - Ø 32 avec h₆-tolerance

Shrink fit extensions (with end stop)
Rallonges de frettage (avec butée)

(DIN 69893-1 | HSK-A)



Verwendung:
Zur Aufnahme von Werkzeugen mit Zylinderschaft.

Application:
For mounting straight-shank tools.

Application:
Pour le serrage d'outils avec queue cylindrique.

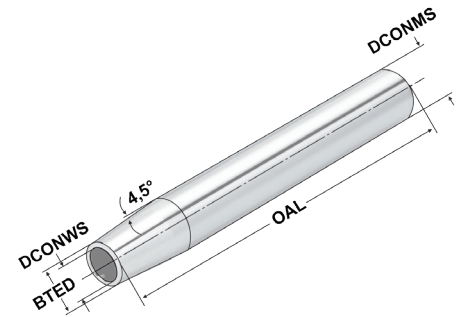

Bestell-Nr. Order no. Référence	DCONMS	DCONWS	BTED	OAL	LSCN	LSCX	ADJRGA	THID
120.70.03	20	3	10	150	6	-	-	-
120.70.04	20	4	10	150	8	-	-	-
120.70.05	20	5	10	150	10	-	-	-
120.70.06*	20	6	10	150	22	36	10	M5x0,8
120.70.08*	20	8	12	150	26	36	10	M6x1
120.70.10*	20	10	14	150	31	41	10	M8x1
120.70.12*	20	12	16	150	36	46	10	M10x1

* mit Anschlag | * with end stop | * avec butée

Durchgangsbohrung für Innenkühlung vorhanden.
Through hole for internal cooling provided.
Trou débouchant disponible pour arrosage interne.

LSCX = Einspannlänge, max. ADJRGA = Verstellweg, max.
LSCX = Clamping depth, max. ADJRGA = Length adjustment range, max.
LSCX = Profondeur d'insertion, max. ADJRGA = Course de réglage, max.

Für Ø 3, 4 und 5 mm nur Hartmetallschäfte verwenden!
For Ø 3, 4 and 5 mm only solid carbide tool shanks must be used!
Pour Ø 3, 4 et 5 mm il faut seulement utiliser de queues d'outils carbures de type HM!

Hinweis: Aufnahmen für Induktiv-, Kontakt- und Heißluftschumpfergeräte geeignet.
Schafttoleranz bei Ø 3, 4 und 5 mm = h₄, bei Ø 6 – Ø 32 mm = h₆

Note: Toolholders suitable for induction-, contact- and hot air shrink units.
Ø 3, 4, 5 with h₄-tolerance and Ø 6 – Ø 32 with h₆-tolerance

Observation: Porte-outils convenables pour machines à fretter par induction, par contact, ou par air chaud.
Ø 3, 4, 5 avec h₄-tolerance et Ø 6 – Ø 32 avec h₆-tolerance

Test arbors
Mandrins de contrôle

(DIN 69893-1 | HSK-A)



Verwendung:
Zur Abnahme von Werkzeugmaschinen gemäß ISO-Empfehlung R230 oder zur Überprüfung der Werkzeugspindel.

Application:
For the inspection of machine tools according to ISO recommendation R230 or for testing the tool spindle.

Application:
Pour l'inspection de machine-outils suite à la recommandation ISO R230 ou pour la vérification de la broche.

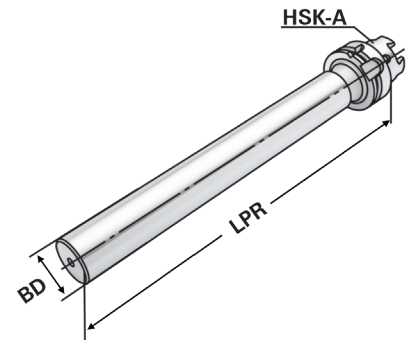

Bestell-Nr. Order no. Référence	HSK	BD	LPR	Toleranz Tolerance Tolérance	max. Rundlaufabweichung max. concentricity deviation Faux-rond max.
A32.18.25	HSK-A 32	25	200	0,003	0,003
A40.18.25	HSK-A 40	25	200	0,003	0,003
A50.18.32	HSK-A 50	32	346	0,003	0,003
A63.18.40	HSK-A 63	40	346	0,003	0,003
A80.18.50	HSK-A 80	40	346	0,003	0,003
A100.18.50	HSK-A 100	50	329	0,003	0,003

Lieferumfang: Auslieferung mit Prüfprotokoll
Delivery: Delivery with test certificate
Livraison: Livraison avec rapport d essais

Holzkasten für Kontrolldorne

Wooden box for test arbors
Coffret en bois pour mandrins de contrôle



Verwendung:
Zur Aufbewahrung von Kontrolldornen.

Application:
For the storage of test arbors.

Application:
Pour la conservation de mandrins de contrôle.



Bestell-Nr. Order no. Référence	Abmessung Size Dimension	für Kegelgrößen for cones pour cônes
701.18	460 × 130 × 115	HSK 32 / 40 / 50 / 63 / 80 / 100

Coolant pipe / Coolant tubes
Canules de lubrification

(DIN 69893-1 | HSK-A)

**Verwendung:**

Zur zentralen Übergabe von Kühlmittel bei HSK-Werkzeugaufnahmen.

Application:

For the coolant supply through the centre of HSK toolholders.

Application:

Pour l'arrosage centrale de porte-outils HSK.

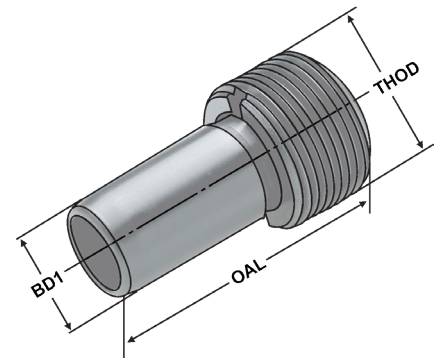
DIN
69895Form
A + E

Bestell-Nr. Order no. Référence	HSK	THOD	BD1	OAL	TQX
A32.700	HSK 32	M10 × 1	6	26,0	5
A40.700	HSK 40	M12 × 1	8	29,5	10
A50.700	HSK 50	M16 × 1	10	33,0	15
A63.700	HSK 63	M18 × 1	12	34,5	20
A80.700	HSK 80	M20 × 1,5	14	40,0	25
A100.700	HSK 100	M24 × 1,5	16	44,0	30

Hinweis:

Nach DIN 69895 für HSK-A und HSK-E Kegel-Hohlschäfte

Axial abgedichtet mit zwei O-Ringen

Dichtigkeit der Verschraubung getestet bis 80 bar

Die Kühlmittelübergabeeinheit ist nach dem Einbau, gemäß DIN, minimal beweglich ($\pm 1^\circ$)**Note:**

According to DIN 69895 for HSK-A and HSK-E hollow taper shanks

Axial sealed with two O-rings

Tightness of the screw connection tested up to 80 bar

After mounting, the coolant tube can be moved only to a minimum degree according to DIN ($\pm 1^\circ$)**Observation:**

Selon DIN 69895 pour HSK-A et HSK-E Tiges creuses coniques

Étanche axiale avec deux joints toriques

étanchéité du raccord testée jusqu'à 80 bar

Après le montage, la canule de lubrification peut être déplacée légèrement suivant DIN ($\pm 1^\circ$)

Key for coolant tubes

(DIN 69893-1 | HSK-A)

Clés pour canules de lubrification



Verwendung:
Zum Montieren der Kühlmittelübergabeeinheiten in HSK-Werkzeugaufnahmen.

Application:
For mounting the coolant tubes in HSK toolholders.

Application:
Pour le montage de canules de lubrification dans des porte-outils HSK.

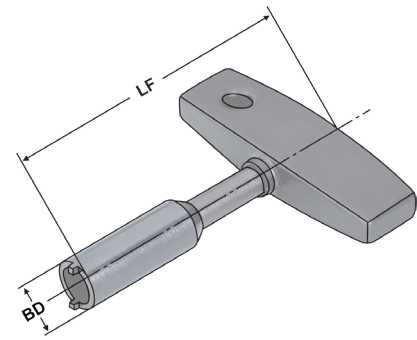
ISO
12164Form
ABestell-Nr.
Order no.
Référence

HSK

BD

LF

A32.701

HSK 32

8,5

115

A40.701

HSK 40

10,5

115

A50.701

HSK 50

14,5

115

A63.701

HSK 63

16,5

136

A80.701

HSK 80

18,5

136

A100.701

HSK 100

22,0

136

Toolholders ISO 12164-1 (formerly DIN 69893) - HSK-C
 Porte-outils ISO 12164-1 (l'ancien DIN 69893) - HSK-C

DIN 69893 | HSK-C

Vorgewuchtet
 Pre-balanced
 Pré-équilibré

G 6,3 15.000 min⁻¹

G 2,5 Feinwuchten gegen Aufpreis
 G 2.5 Fine balancing at extra charge
 G 2,5 Equilibrage fin contre un supplément

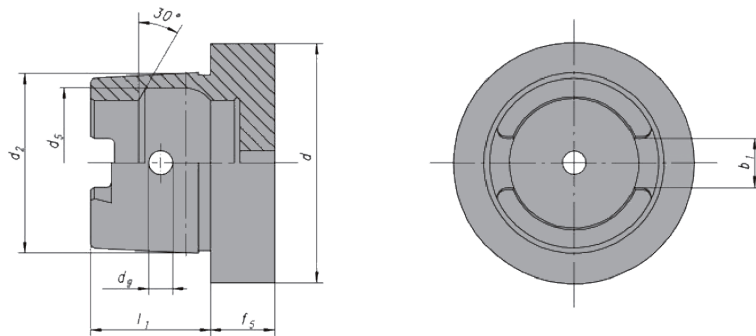

d ₁	l ₁	f ₅	d ₂	d ₅	d ₉	b ₁
32	16	10	24	21	4	7,05
40	20	10	30	25,5	4,6	8,05
50	25	12,5	38	32	6	10,54
63	32	12,5	48	40	7,5	12,54
80	40	16	60	50	8,5	16,04
100	50	16	75	63	12	20,02

Werkstoff: Legierter Einsatzstahl mit einer Zugfestigkeit im Kern von min. 950 N / mm². Einsatzgehärtet HRC 60 ± 2 (HV 700 ± 50), Härtetiefe 0,8 mm ± 0,2 mm, brüniert und präzisionsgeschliffen.

Genauigkeit: Kegelwinkel – Toleranzqualität < AT 3 nach DIN 7187.

Material: Alloyed case-hardened steel, tensile core strength of min. 950 N / mm². Case hardened HRC 60 ± 2 (HV 700 ± 50), hardening depth 0.8 mm ± 0.2 mm, black-finished and precisely grinded.

Accuracy: Quality of taper < AT 3 according to DIN 7187.

Matière: Acier de cémentation allié. Résistance à la traction dans le noyau de min 950 N / mm². Cémentation à HRC 60 ± 2 (HV 700 ± 50), profondeur de cémentation 0,8 mm ± 0,2 mm, bruni et rectifié précisément.

Précision: Qualité du cône < AT 3 suivant DIN 7187.

Normative Verweise:

ISO 12164-1:2001-12
 Hohlkegelschnittstelle mit Plananlage
 - Teil 1: Schäfte; Maße

Normative references:

ISO 12164-1:2001
 Hollow taper interface with flange contact surface
 - Part 1: Shanks; Dimensions

Références normatives:

ISO 12164-1:2001
 Interfaces à cône creux-face
 - Partie 1: Queues; Dimensions

DIN 69893-1:2011
 Kegel-Hohlschäfte mit Plananlage besteht aus:
 - Teil 1: Kegel-Hohlschäfte Form A und Form C;
 Maße und Ausführung

DIN 69893-1:2011
 Hollow taper shanks with flange contact surface:
 - Part 1: Hollow taper shanks type A and type C;
 Dimensions and design

DIN 69893-1:2011
 Queues creuses coniques à surface de contact plane:
 - Partie 1: Queues creuses coniques type A et type C;
 Dimensions et conception

5.53



5.54



5.58



5.59



5.60



5.61



5.63



5.65



Collet chucks for collets ISO 15488 (DIN 6499) ER-system

DIN 69893 | HSK-C

Mandrins à pinces pour pinces ISO 15488 (DIN 6499) système ER

**Verwendung:**

Zur Aufnahme von Werkzeugen mit Zylinderschaft in Spannzangen.

Application:

For mounting straight-shank tools in collets.

Application:

Destiné à recevoir les outils avec les queues de forme cylindrique dans les pinces de serrage.

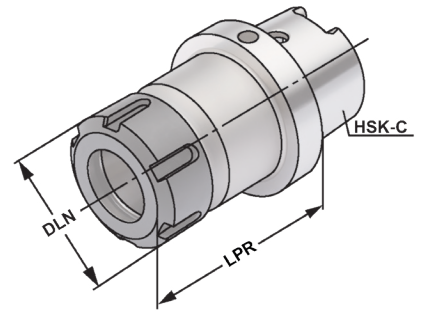

Bestell-Nr. Order no. Référence	HSK	DCONWS Spannbereich Capacity Capacité	Typ	LPR	DLN
C25.02.07.M ¹	HSK-C 25	1 - 7	4008E ER 11 Mini	40	16
C25.02.10.M ¹	HSK-C 25	1 - 10	426E ER 16 Mini	55	22
C32.02.10 ²	HSK-C 32	1 - 10	426E ER 16	60	28
C40.02.10.M ¹	HSK-C 40	1 - 10	426E ER 16 Mini	70	22
C40.02.10 ²	HSK-C 40	1 - 10	426E ER 16	60	28
C40.02.16	HSK-C 40	2 - 16	430E ER 25	70	42
C40.02.20	HSK-C 40	2 - 20	470E ER 32	75	50
C40.02.26	HSK-C 40	3 - 26	472E ER 40	85	63
C50.02.10 ²	HSK-C 50	1 - 10	426E ER 16	60	28
C50.02.10.1	HSK-C 50	1 - 10	426E ER 16	100	28
C50.02.16	HSK-C 50	2 - 16	430E ER 25	70	42
C50.02.20	HSK-C 50	2 - 20	470E ER 32	80	50
C50.02.26	HSK-C 50	3 - 26	472E ER 40	80	63
C63.02.10 ²	HSK-C 63	1 - 10	426E ER 16	60	28
C63.02.10.1	HSK-C 63	1 - 10	426E ER 16	100	28
C63.02.16	HSK-C 63	2 - 16	430E ER 25	70	42
C63.02.20	HSK-C 63	2 - 20	470E ER 32	75	50
C63.02.26	HSK-C 63	3 - 26	472E ER 40	80	63
C80.02.10 ²	HSK-C 80	1 - 10	426E ER 16	100	28
C80.02.10.1	HSK-C 80	1 - 10	426E ER 16	160	28
C80.02.20	HSK-C 80	2 - 20	470E ER 32	80	50
C80.02.26	HSK-C 80	3 - 26	472E ER 40	85	63
C100.02.10 ²	HSK-C 100	1 - 10	426E ER 16	100	28
C100.02.10.1 ²	HSK-C 100	1 - 10	426E ER 16	160	28
C100.02.20	HSK-C 100	2 - 20	470E ER 32	80	50
C100.02.26	HSK-C 100	3 - 26	472E ER 40	90	63

¹ Minimutter¹ Mini nut¹ Ecrous mini² Sechskantmutter² Hexagonal clamping nut² Écrous hexagonal**Lieferumfang:****Delivery:****Livraison:**

Mit gewichteter Spannmutter

With balanced clamping nut

Avec écrou de serrage équilibré



End mill holders DIN 6359 for end mills DIN 1835-B

DIN 69893 | HSK-C

Porte-fraises DIN 6359 pour queues cylindriques DIN 1835-B

**Verwendung:**

Zum Spannen von zylindrischen Werkzeugschäften mit seitlicher Spannfläche nach DIN 1835 Form B (Weldon).

Application:

For mounting straight-shank tools with lateral flat according to DIN 1835 form B (Weldon).

Application:

Pour le serrage d'outils avec queue cylindrique et avec méplat de serrage latérale suivant DIN 1835 forme B (Weldon).

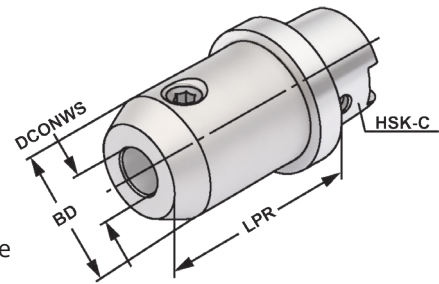

Bestell-Nr. Order no. Référence	HSK	DCONWS	TDCON	LPR	BD
C40.04.08	HSK-C 40	8	H4	60	28
C40.04.10	HSK-C 40	10	H4	70	35
C40.04.12	HSK-C 40	12	H4	70	42
C40.04.14	HSK-C 40	14	H4	75	44
C40.04.16	HSK-C 40	16	H4	75	48
C40.04.18	HSK-C 40	18	H4	80	50
C40.04.20	HSK-C 40	20	H4	80	52
C50.04.06	HSK-C 50	6	H4	60	25
C50.04.08	HSK-C 50	8	H4	60	28
C50.04.10	HSK-C 50	10	H4	65	35
C50.04.12	HSK-C 50	12	H4	75	42
C50.04.14	HSK-C 50	14	H4	75	44
C50.04.16	HSK-C 50	16	H4	80	48
C50.04.18	HSK-C 50	18	H4	80	50
C50.04.20	HSK-C 50	20	H4	80	50
C50.04.25	HSK-C 50	25	H4	80	50
C63.04.06	HSK-C 63	6	H4	60	25
C63.04.08	HSK-C 63	8	H4	60	28
C63.04.10	HSK-C 63	10	H4	65	35
C63.04.12	HSK-C 63	12	H4	75	42
C63.04.14	HSK-C 63	14	H4	75	44
C63.04.16	HSK-C 63	16	H4	80	48
C63.04.18	HSK-C 63	18	H4	80	50
C63.04.20	HSK-C 63	20	H4	80	52
C63.04.25	HSK-C 63	25	H4	95	65
C63.04.32	HSK-C 63	32	H4	100	72

Hinweis: Ab DCONWS = 25 mit zwei Spannschrauben
Note: From DCONWS = 25 on two clamping screws
Observation: A partir de DCONWS = 25 avec deux vis de serrage

Lieferumfang: Mit Spannschraube
Delivery: With clamping screw
Livraison: Avec vis de serrage



**Verwendung:**

Zum Spannen von zylindrischen Werkzeugschäften mit seitlicher Spannfläche nach DIN 1835 Form B (Weldon).

Application:

For mounting straight-shank tools with lateral flat according to DIN 1835 form B (Weldon).

Application:

Pour le serrage d'outils avec queue cylindrique et avec méplat de serrage latérale suivant DIN 1835 forme B (Weldon).

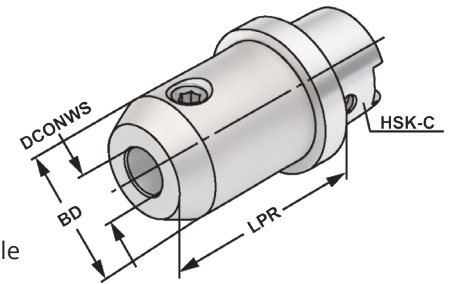

Bestell-Nr. Order no. Référence	HSK	DCONWS	TDCON	LPR	BD
C100.04.06	HSK-C 100	6	H4	65	25
C100.04.08	HSK-C 100	8	H4	65	28
C100.04.10	HSK-C 100	10	H4	70	35
C100.04.12	HSK-C 100	12	H4	75	42
C100.04.14	HSK-C 100	14	H4	75	44
C100.04.16	HSK-C 100	16	H4	80	48
C100.04.18	HSK-C 100	18	H4	80	50
C100.04.20	HSK-C 100	20	H4	85	52
C100.04.25	HSK-C 100	25	H4	95	65
C100.04.32	HSK-C 100	32	H4	100	72
C100.04.40	HSK-C 100	40	H4	100	80

Hinweis: Ab DCONWS = 25 mit zwei Spannschrauben
Note: From DCONWS = 25 on two clamping screws
Observation: A partir de DCONWS = 25 avec deux vis de serrage

Lieferumfang: Mit Spannschraube
Delivery: With clamping screw
Livraison: Avec vis de serrage

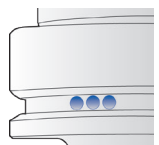
Gewuchtete Ausführung**Balanced type
Type équilibré**

Bestell-Nr. Order no. Référence	Abmessung Size Dimension
---------------------------------------	--------------------------------

Wuchten auf G 2,5 von vorgewuchteten Kemmler-Werkzeugen

Balancing at G 2.5 of pre-balanced Kemmler-tools
 Equilibrage sur G 2,5 d'outils Kemmler pré-équilibrés

W25 **Ohne Wuchtprotokoll**
Without balancing report
Sans protocole d'équilibrage

W25.2 **Mit Wuchtprotokoll**
With balancing report
Avec protocole d'équilibrage

Wuchten von nicht vorgewuchteten Werkzeugen
Balancing of unbalanced tools
Equilibrage d'outils non-équilibrés

W25.1 **Ohne Wuchtprotokoll**
Without balancing report
Sans protocole d'équilibrage



End mill holders DIN 6359 for end mills DIN 1835-E

DIN 69893 | HSK-C

Porte-fraises DIN 6359 pour queues cylindriques DIN 1835-E

**Verwendung:**

Zum Spannen von zylindrischen Werkzeugschäften mit geneigter Spannfläche nach DIN 1835 Form E (Whistle Notch).

Application:

For mounting straight-shank tools and inclined flat according to DIN 1835 form E (Whistle Notch).

Application:

Pour le serrage d'outils avec queue cylindrique et avec méplat incliné suivant DIN 1835 forme E (Whistle Notch).

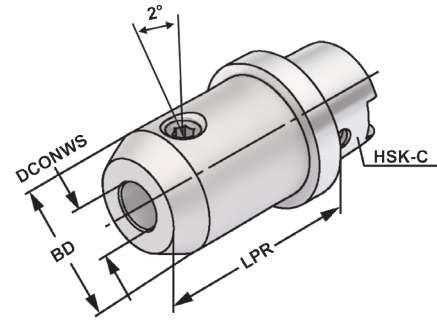

ISO

12164

Form

C

 $\le 3\mu\text{m}$ 

G6.3

15.000

min⁻¹

DIN

1835-E

H4



13.04

Bestell-Nr.
Order no.
Référence

HSK

DCONWS

TDCON

LPR

BD

C32.05.06

HSK-C 32

6

H4

60

25

C32.05.08

HSK-C 32

8

H4

60

28

C32.05.10

HSK-C 32

10

H4

65

35

C32.05.12

HSK-C 32

12

H4

70

42

C32.05.14

HSK-C 32

14

H4

70

44

C40.05.06

HSK-C 40

6

H4

60

25

C40.05.08

HSK-C 40

8

H4

60

28

C40.05.10

HSK-C 40

10

H4

65

35

C40.05.12

HSK-C 40

12

H4

70

40

C40.05.14

HSK-C 40

14

H4

70

40

C40.05.16

HSK-C 40

16

H4

75

40

C40.05.18

HSK-C 40

18

H4

75

40

C40.05.20

HSK-C 40

20

H4

80

48

C40.05.25

HSK-C 40

25

H4

100

46

C50.05.06

HSK-C 50

6

H4

60

25

C50.05.08

HSK-C 50

8

H4

60

28

C50.05.10

HSK-C 50

10

H4

65

35

C50.05.12

HSK-C 50

12

H4

75

42

C50.05.14

HSK-C 50

14

H4

75

44

C50.05.16

HSK-C 50

16

H4

80

48

C50.05.18

HSK-C 50

18

H4

80

50

C50.05.20

HSK-C 50

20

H4

80

52

C50.05.25

HSK-C 50

25

H4

85

65

Hinweis:

Ab DCONWS = 25 mit zwei Spanschrauben

Note:

From DCONWS = 25 on two clamping screws

Observation:

A partir de DCONWS = 25 avec deux vis de serrage

Lieferumfang:

Mit Spanschraube und axialer Verstellechraube

Delivery:

With clamping screw and axial adjustment bolt

Livraison:

Avec vis de serrage et vis de butée axiale



10.64

End mill holders DIN 6359 for end mills DIN 1835-E

DIN 69893 | HSK-C

Porte-fraises DIN 6359 pour queues cylindriques DIN 1835-E

**Verwendung:**

Zum Spannen von zylindrischen Werkzeugschäften mit geneigter Spannfläche nach DIN 1835 Form E (Whistle Notch).

Application:

For mounting straight-shank tools and inclined flat according to DIN 1835 form E (Whistle Notch).

Application:

Pour le serrage d'outils avec queue cylindrique et avec méplat incliné suivant DIN 1835 forme E (Whistle Notch).

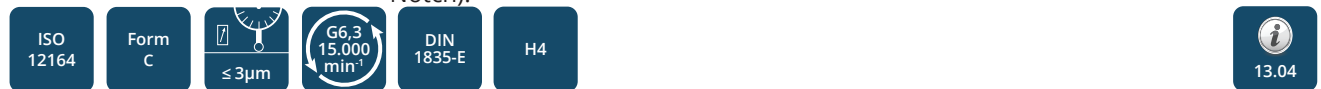
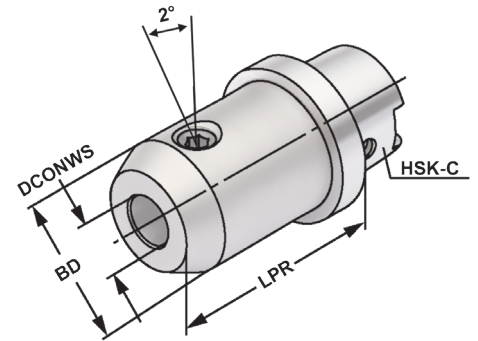

Bestell-Nr. Order no. Référence	HSK	DCONWS	TDCON	LPR	BD
C63.05.06	HSK-C 63	6	H4	60	25
C63.05.08	HSK-C 63	8	H4	60	28
C63.05.10	HSK-C 63	10	H4	65	35
C63.05.12	HSK-C 63	12	H4	75	42
C63.05.14	HSK-C 63	14	H4	75	44
C63.05.16	HSK-C 63	16	H4	80	48
C63.05.18	HSK-C 63	18	H4	80	50
C63.05.20	HSK-C 63	20	H4	80	52
C63.05.25	HSK-C 63	25	H4	95	65
C63.05.32	HSK-C 63	32	H4	100	72
C80.05.06	HSK-C 80	6	H4	65	25
C80.05.08	HSK-C 80	8	H4	65	28
C80.05.10	HSK-C 80	10	H4	70	35
C80.05.12	HSK-C 80	12	H4	75	42
C80.05.14	HSK-C 80	14	H4	75	44
C80.05.16	HSK-C 80	16	H4	80	48
C80.05.18	HSK-C 80	18	H4	80	50
C80.05.20	HSK-C 80	20	H4	85	52
C80.05.25	HSK-C 80	25	H4	95	65
C80.05.32	HSK-C 80	32	H4	100	72
C100.05.06	HSK-C 100	6	H4	65	25
C100.05.08	HSK-C 100	8	H4	65	28
C100.05.10	HSK-C 100	10	H4	70	35
C100.05.12	HSK-C 100	12	H4	75	42
C100.05.14	HSK-C 100	14	H4	75	44
C100.05.16	HSK-C 100	16	H4	80	48
C100.05.18	HSK-C 100	18	H4	80	50
C100.05.20	HSK-C 100	20	H4	85	52
C100.05.25	HSK-C 100	25	H4	95	65
C100.05.32	HSK-C 100	32	H4	100	72

Hinweis: Ab DCONWS = 25 mit zwei Spannschrauben
Note: From DCONWS = 25 on two clamping screws
Observation: A partir de DCONWS = 25 avec deux vis de serrage

Lieferumfang: Mit Spannschraube und axialer Verstelle schraube
Delivery: With clamping screw and axial adjustment bolt
Livraison: Avec vis de serrage et vis de butée axiale

Shell mill holders DIN 6357 with enlarged contact face
 Porte-fraises à trou lisse DIN 6357 avec face de contact élargie



Verwendung:
 Zur Aufnahme von Messerköpfen und Fräsern mit Quernut.

Application:
 For mounting milling cutters with transversal groove.

Application:
 Destiné à recevoir les fraises et les fraises avec des rainures transversales.

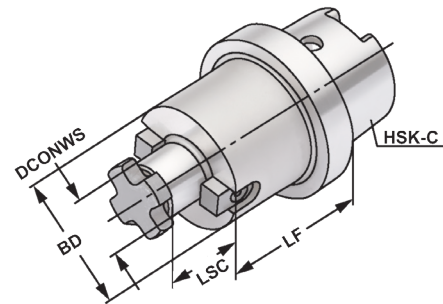

ISO 12164 Form C $\leq 5\mu\text{m}$ G6.3 15.000 min⁻¹ DIN 6357 h6

Bestell-Nr. Order no. Référence	HSK	DCONWS	TCDCON	LF	LSC	BD
C40.11.16	HSK-C 40	16	h6	50	17	40
C40.11.22	HSK-C 40	22	h6	60	19	40
C50.11.16	HSK-C 50	16	h6	60	17	40
C50.11.22	HSK-C 50	22	h6	60	19	50
C50.11.27	HSK-C 50	27	h6	60	21	50
C63.11.22	HSK-C 63	22	h6	50	19	48
C63.11.27	HSK-C 63	27	h6	60	21	60
C63.11.32	HSK-C 63	32	h6	60	24	78
C63.11.40	HSK-C 63	40	h6	60	27	89
C80.11.32	HSK-C 80	32	h6	48	24	78
C80.11.32.1	HSK-C 80	32	h6	60	24	78
C80.11.40	HSK-C 80	40	h6	60	27	89
C100.11.22	HSK-C 100	22	h6	50	19	48
C100.11.27	HSK-C 100	27	h6	50	21	60
C100.11.32	HSK-C 100	32	h6	50	24	78
C100.11.40	HSK-C 100	40	h6	60	27	89
C100.11.50	HSK-C 100	50	h6	70	30	120

DCONWS = 40 & 50 Für große Planfräser mit vier zusätzlichen Gewindebohrungen nach DIN 2079.
 For large diameter face mill cutters with four additional threaded holes according to DIN 2079.
 Pour fraises à surfacer à grands diamètres avec 4 taraudages supplémentaires suivant DIN 2079.

- Lieferumfang:** Mit Mitnehmersteinen, Kreuzschraube und Zylinderkopfschraube nach DIN 912 für Fräser mit innerer Kühlmittelzufuhr.
 Bei DCONWS = 60 nur mit vier Befestigungsschrauben nach DIN 912.
- Delivery:** With drivers, cross head retaining screw and cylinder head retaining screw for cutters with central coolant.
 For DCONWS = 60 only with four fixation screws according to DIN 912.
- Livraison:** Avec tenon d entraînement, vis cruciforme et vis à têtes cylindrique suivant DIN 912 pour les fraises avec arrosage central.
 Pour DCONWS = 60 est seulement avec quatre vis de fixation suivant DIN 912.





Verwendung:
Zur Aufnahme von Werkzeugen mit Zylinderschaft.

Application:
For mounting tools with straight shanks.

Application:
Pour le serrage d'outils avec queue cylindrique.

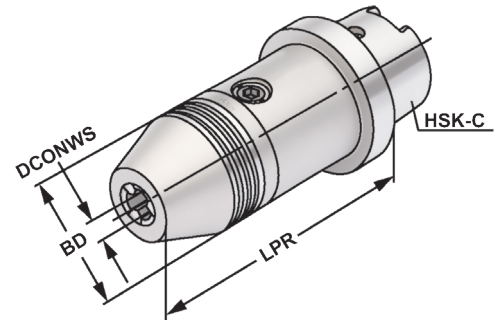

Bestell-Nr. Order no. Référence	HSK	DCONWS Spannbereich Capacity Capacité	LPR	BD	DRVS
C50.15.13	HSK-C 50	1,0 – 13	110	50	6
C50.15.16	HSK-C 50	2,5 – 16	115,5	50	6
C63.15.13	HSK-C 63	1,0 – 13	110	50	6
C63.15.16	HSK-C 63	2,5 – 16	115,5	50	6
C100.15.13	HSK-C 100	1,0 – 13	112,5	50	6
C100.15.16	HSK-C 100	2,5 – 16	118	50	6

Hinweis: Hohe Präzision und Rundlaufgenauigkeit von $\leq 0,03$ mm. Sichere Spannung des Werkzeuges durch mechanische Spannkraftverstärkung. Kein selbständiges Lösen der Spannung während der Bearbeitung bei Links- oder Rechtslauf, sowie bei Spindelstop. Spannen und Lösen mit Sechskantschlüssel.

Note: High precision and accurate concentricity of ≤ 0.03 mm. Secure gripping of the tool through mechanical amplification of the clamping force. No automatic slackening of the clamping force while machining with either clockwise or counter clockwise rotation or on spindle stop. Clamping and releasing effected by means of an Allen wrench.

Observation: Précision élevée et exactitude de circularité de $\leq 0,03$ mm. Serrage sûr de l'outil grâce à l'amplification de la force de serrage. Pas de desserrage intempestif en cours d'usinage lors de la rotation la gauche ou la droite, de même qu'en cas d'arrêt de la broche. Serrage et desserrage en utilisant un clé sur à fourche.

Lieferumfang: Ohne Spannschlüssel
Delivery: Without wrench
Livraison: Sans clé de serrage





Verwendung:
Zur Herstellung von Sonderwerkzeugen.

Application:
For the manufacturing of special tools.

Application:
Pour la fabrication d'outils spéciaux.

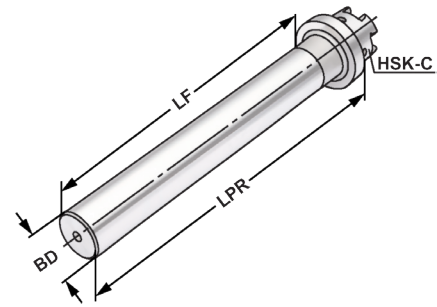
ISO
12164Form
C

Bestell-Nr. Order no. Référence	HSK	LPR	BD
C25.17.32	HSK-C 25	110	32
C32.17.32	HSK-C 32	160	32
C40.17.50	HSK-C 40	160	43
C50.17.50	HSK-C 50	200	50
C63.17.63	HSK-C 63	250	63
C80.17.80	HSK-C 80	250	80
C100.17.93	HSK-C 100	250	93

Ausführung: Kegel und Bund gehärtet und geschliffen. Schaft weich zur weiteren Bearbeitung.
Version: Cone and flange hardened and grinded. Soft body for later processing.
Version: Cône et collerette durcis et rectifiés. Corps doux pour un usinage ultérieur.

Gewuchtete Ausführung

Balanced type Type équilibré

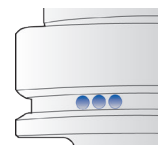

Bestell-Nr. Order no. Référence	Abmessung Size Dimension
---------------------------------------	--------------------------------

Wuchten auf G 2,5 von vorgewuchteten Kemmler-Werkzeugen

Balancing at G 2.5 of pre-balanced Kemmler-tools
Équilibrage sur G 2,5 d'outils Kemmler pré-équilibrés

W25

Ohne Wuchtprotokoll
Without balancing report
Sans protocole d'équilibrage

W25.2

Mit Wuchtprotokoll
With balancing report
Avec protocole d'équilibrage

Wuchten von nicht vorgewuchteten Werkzeugen
Balancing of unbalanced tools
Équilibrage d'outils non-équilibrés

W25.1

Ohne Wuchtprotokoll
Without balancing report
Sans protocole d'équilibrage

Test arbors
Mandrins de contrôle

DIN 69893 | HSK-C



Verwendung:
Zur Abnahme von Werkzeugmaschinen gemäß ISO-Empfehlung R230 oder zur Überprüfung der Werkzeugspindel.

Application:
For the inspection of machine tools according to ISO recommendation R230 or for testing the tool spindle.

Application:
Pour l'inspection de machine-outils suite à la recommandation ISO R230 ou pour la vérification de la broche.

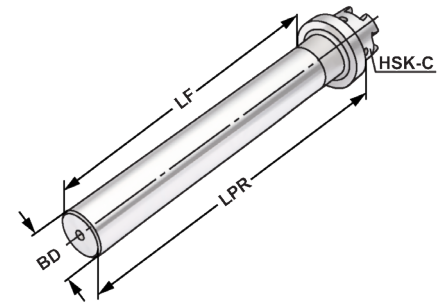

Bestell-Nr. Order no. Référence	HSK	BD	LPR	LF	Toleranz Tolerance Tolérance	max. Rundlaufabweichung max. concentricity deviation Faux-ronnd max.
C32.18.25	HSK-C 32	25	160	140	0,003	0,003
C40.18.25	HSK-C 40	25	160	140	0,003	0,003
C50.18.32	HSK-C 50	32	300	275	0,003	0,003
C63.18.40	HSK-C 63	40	300	275	0,003	0,003
C80.18.40	HSK-C 80	40	300	275	0,003	0,003
C100.18.50	HSK-C 100	50	300	275	0,003	0,003

Lieferumfang: Auslieferung mit Prüfprotokoll
Delivery: Delivery with test certificate
Livraison: Livraison avec rapport d'essais

Holzkasten für Kontrolldorne

Wooden box for test arbors
Coffret en bois pour mandrins de contrôle



Verwendung:
Zur Aufbewahrung von Kontrolldornen.

Application:
For the storage of test arbors.

Application:
Pour la conservation de mandrins de contrôle.



Bestell-Nr. Order no. Référence	Abmessung Size Dimension	für Kegelgrößen for cones pour cônes
701.18	460 × 130 × 115	HSK 32 / 40 / 50 / 63 / 80 / 100



Verwendung:

Für einfaches und sicheres Klemmen von Werkzeugaufnahmen am Bund mittels Rollen zum Montieren und Demontieren von Schneidwerkzeugen. Reibschlüssig, daher selbstklemmend und ideal für HSK Formen E und F sowie Polygonschaft Aufnahmen.

Application:

For easy and reliable clamping of tool arbors at the collar using rollers to mount and remove cutting tools – friction lock is self-clamping and ideal for HSK forms E and F, and also polygon shank arbors.

Application:

Pour le serrage simple et sûr de porte-outils au niveau de la collerette à l'aide de galets pour le montage et le démontage d'outils de coupe – entraînement par friction, autoserrant.

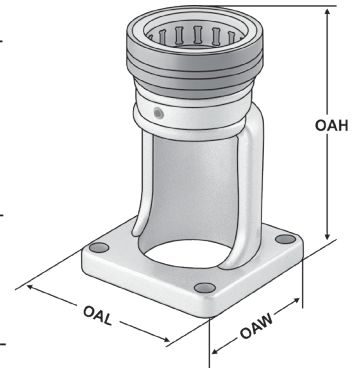

Bestell-Nr. Order no. Référence	Abmessung Size Dimension	OAL	OAW	OAH
707.1.032	HSK A32 - C32 - E32 - F32 - C3	110	110	165
707.1.040	HSK A40 - C40 - E40 - F40 - C4	110	110	165
707.1.050	HSK A50 - C50 - E50 - F50 - SK30 - C5	110	110	165
707.1.063	HSK A63 - C63 - E63 - F63 - BT40 - C6	110	110	172
707.1.080	HSK A80 - C80 - E80 - F80 - C8	160	160	215
707.1.100	HSK A100	160	160	219
707.1.BT30	BT30	110	110	165
707.1.SK40	SK40	110	110	172
707.1.SK50	SK50	160	160	219



Verwendung:
Zur Aufnahme von Werkzeugen mit Zylinderschaft nach DIN 1835 Form A+B+E und DIN 6535 Form HA+HB+HE

Application:
For mounting straight-shank tools acc. DIN 1835 form A+B+E and DIN 6535 form HA+HB+HE.

Application:
Pour le serrage d'outils avec queue cylindrique suivant DIN 1835 forme A+B+E et DIN 6535 forme HA+HB+HE.

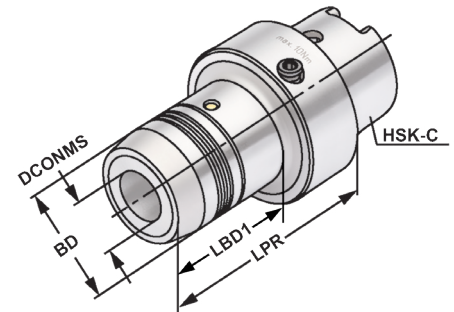

Bestell-Nr. Order no. Référence	HSK	DCONWS	LPR	BD	LSCX	ADJRGA	LBD1	DRVS	THID
C25.H06	HSK-C 25	6	60	26	37	10	38	5	M5x0,8
C25.H08	HSK-C 25	8	60	28	37	10	38	5	M5x0,8
C25.H10	HSK-C 25	10	65	30	42	10	38	5	M5x0,8
C32.H06	HSK-C 32	6	60	26	37	10	35	5	M5x0,8
C32.H08	HSK-C 32	8	60	28	37	10	36	5	M6x1
C32.H10	HSK-C 32	10	65	30	42	10	52	5	M8x1
C32.H12	HSK-C 32	12	70	32	47	10	-	5	M10x1
C32.H14	HSK-C 32	14	75	34	47	10	65	6	M10x1
C40.H06	HSK-C 40	6	60	26	37	10	35	5	M5x0,8
C40.H08	HSK-C 40	8	60	28	37	10	36	5	M6x1
C40.H10	HSK-C 40	10	65	30	42	10	38	5	M8x1
C40.H12	HSK-C 40	12	70	32	47	10	47	5	M10x1
C40.H14	HSK-C 40	14	80	34	47	10	49	5	M10x1
C40.H16	HSK-C 40	16	80	38	52	10	49	5	M12x1
C40.H18	HSK-C 40	18	80	40	52	10	49	5	M12x1
C40.H20	HSK-C 40	20	80	40	52	10	49	5	M12x1
C50.H06	HSK-C 50	6	60	26	37	10	33	5	M5x0,8
C50.H08	HSK-C 50	8	60	28	37	10	33	5	M6x1
C50.H10	HSK-C 50	10	65	30	42	10	39	5	M8x1
C50.H12	HSK-C 50	12	75	32	47	10	44	5	M10x1
C50.H14	HSK-C 50	14	75	34	47	10	46	5	M10x1
C50.H16	HSK-C 50	16	80	38	52	10	51	5	M12x1
C50.H18	HSK-C 50	18	80	40	52	10	52	5	M12x1
C50.H20	HSK-C 50	20	80	42	52	10	58	5	M12x1

LSCX = Einspannlänge, max. ADJRGA = Verstellweg, max.
LSCX = Clamping depth, max. ADJRGA = Length adjustment range, max.
LSCX = Profondeur d'insertion, max. ADJRGA = Course de réglage, max.

Lieferumfang: Ohne Spannschlüssel
Delivery: Without wrench
Livraison: Sans clé de serrage





Verwendung:
Zur Aufnahme von Werkzeugen mit Zylinderschaft nach DIN 1835 Form A+B+E und DIN 6535 Form HA+HB+HE

Application:
For mounting straight-shank tools acc. DIN 1835 form A+B+E and DIN 6535 form HA+HB+HE.

Application:
Pour le serrage d'outils avec queue cylindrique suivant DIN 1835 forme A+B+E et DIN 6535 forme HA+HB+HE.

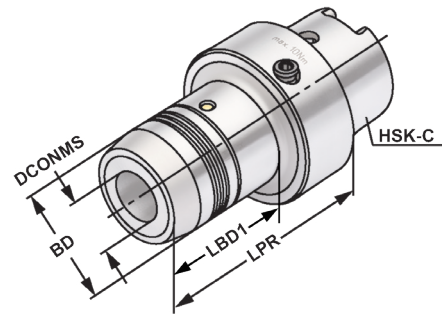

Bestell-Nr. Order no. Référence	HSK	DCONWS	LPR	BD	LSCX	ADJRGA	LBD1	DRVS	THID
C63.H06	HSK-C 63	6	60	26	37	10	29	5	M5x0,8
C63.H08	HSK-C 63	8	60	28	37	10	29	5	M6x1
C63.H10	HSK-C 63	10	65	30	42	10	35	5	M8x1
C63.H12	HSK-C 63	12	75	32	47	10	40	5	M10x1
C63.H14	HSK-C 63	14	75	34	47	10	42	5	M10x1
C63.H16	HSK-C 63	16	80	38	52	10	47	5	M12x1
C63.H18	HSK-C 63	18	80	40	52	10	48	5	M12x1
C63.H20	HSK-C 63	20	80	42	52	10	54	5	M12x1
C63.H25	HSK-C 63	25	95	50	58	10	51	6	M16x1
C63.H32	HSK-C 63	32	100	60	62	10	59	6	M16x1

LSCX = Einspannlänge, max. ADJRGA = Verstellweg, max.
LSCX = Clamping depth, max. ADJRGA = Length adjustment range, max.
LSCX = Profondeur d'insertion, max. ADJRGA = Course de réglage, max.

Lieferumfang: Ohne Spanschlüssel
Delivery: Without wrench
Livraison: Sans clé de serrage

Gewuchtete Ausführung

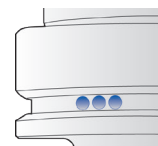

Balanced type
Type équilibré

Bestell-Nr. Order no. Référence	Abmessung Size Dimension
---------------------------------------	--------------------------------

Wuchten auf G 2,5 von vorgewuchteten
Kemmler-Werkzeugen

Balancing at G 2.5 of pre-balanced Kemmler-tools

Équilibrage sur G 2,5 d'outils Kemmler pré-équilibrés

W25 Ohne Wuchtprotokoll
Without balancing report

W25.2 Mit Wuchtprotokoll
With balancing report

Wuchten von nicht vorgewuchteten Werkzeugen
Balancing of unbalanced tools

W25.1 Ohne Wuchtprotokoll
Without balancing report

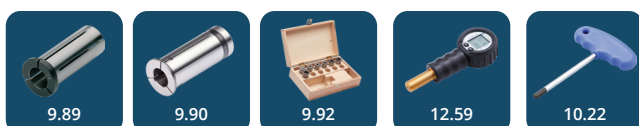

Shrink chucks 4,5° for mounting of solid carbide and HSS-tool shanks

Mandrins de frettage 4,5° pour le serrage de queues d'outils carbures de type HM et HSS



Verwendung:

Zur Aufnahme von Werkzeugen mit Zylinderschaft.

Application:

For mounting straight-shank tools.

Application:

Pour le serrage d'outils avec queue cylindrique.

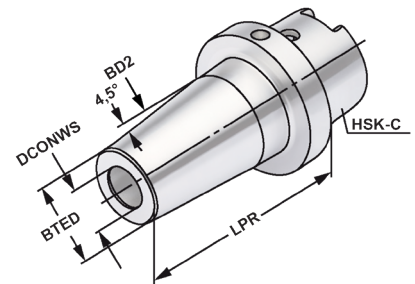

Bestell-Nr. Order no. Référence	HSK	DCONWS	TDCON	LPR	BTED	BD2	LSCN	LSCX	ADJRGA	THID
C32.70.06	HSK-C 32	6	h6	65	21	27	15	20	5	M4
C32.70.08	HSK-C 32	8	h6	65	21	27	26	36	10	M6
C32.70.10	HSK-C 32	10	h6	65	24	32	32	42	10	M8x1
C32.70.12	HSK-C 32	12	h6	75	24	32	37	47	10	M10x1
C32.70.14	HSK-C 32	14	h6	80	27	34	37	47	10	M10x1
C32.70.16	HSK-C 32	16	h6	80	27	34	40	50	10	M12x1
C40.70.03	HSK-C 40	3	h4	70	11	15	9	10	-	-
C40.70.04	HSK-C 40	4	h4	70	14	22	15	20	5	M3
C40.70.05	HSK-C 40	5	h4	70	16	22	15	20	5	M4
C40.70.06	HSK-C 40	6	h6	70	21	27	26	36	10	M5x0,8
C40.70.08	HSK-C 40	8	h6	70	21	27	26	36	10	M6x1
C40.70.10	HSK-C 40	10	h6	70	24	32	32	42	10	M8x1
C40.70.12	HSK-C 40	12	h6	80	24	32	37	47	10	M10x1
C40.70.14	HSK-C 40	14	h6	80	27	34	37	47	10	M10x1
C40.70.16	HSK-C 40	16	h6	80	27	34	40	50	10	M12x1
C40.70.18	HSK-C 40	18	h6	80	33	42	40	50	10	M12x1
C40.70.20	HSK-C 40	20	h6	80	33	42	42	52	10	M16x1
C50.70.06	HSK-C 50	6	h6	70	21	27	26	36	10	M5x0,8
C50.70.08	HSK-C 50	8	h6	70	21	27	26	36	10	M6x1
C50.70.10	HSK-C 50	10	h6	75	24	32	32	42	10	M8x1
C50.70.12	HSK-C 50	12	h6	75	24	32	37	47	10	M10x1
C50.70.14	HSK-C 50	14	h6	80	27	34	37	47	10	M10x1
C50.70.16	HSK-C 50	16	h6	85	27	34	40	50	10	M12x1
C50.70.18	HSK-C 50	18	h6	85	33	42	40	50	10	M12x1
C50.70.20	HSK-C 50	20	h6	90	33	42	42	52	10	M16x1

LSCX = Einspannlänge, max.
LSCX = Clamping depth, max.
LSCX = Profondeur d'insertion, max.

ADJRGA = Verstellweg, max.
ADJRGA = Length adjustment range, max.
ADJRGA = Course de réglage, max.

Hinweis: Aufnahme für Induktiv-, Kontakt- und Heißluftschrimpferäte geeignet.
Schafttoleranz bei Ø 3, 4 und 5 mm = h₄, bei Ø 6 - Ø 32 mm = h₆

Note: Toolholders suitable for induction-, contact- and hot air shrink units.
Ø 3, 4, 5 with h₄-tolerance and Ø 6 - Ø 32 with h₆-tolerance

Observation: Porte-outils convenables pour machines à fretter par induction, par contact, ou par air chaud.
Ø 3, 4, 5 avec h₄-tolerance et Ø 6 - Ø 32 avec h₆-tolerance

Shrink chucks 4,5° for mounting of solid carbide and HSS-tool shanks

Mandrins de frettage 4,5° pour le serrage de queues d'outils carbures de type HM et HSS



Verwendung:
Zur Aufnahme von Werkzeugen mit Zylinderschaft.

Application:
For mounting straight-shank tools.

Application:
Pour le serrage d'outils avec queue cylindrique.

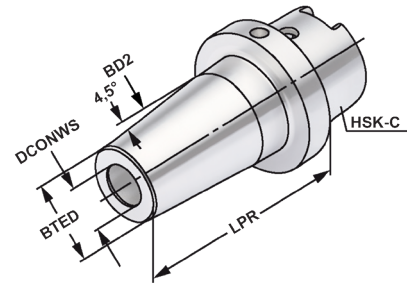

Bestell-Nr. Order no. Référence	HSK	DCONWS	TDCON	LPR	BTED	BD2	LSCN	LSCX	ADJRG	THID
C63.70.06	HSK-C 63	6	h6	70	21	27	26	36	10	M5x0,8
C63.70.08	HSK-C 63	8	h6	70	21	27	26	36	10	M6x1
C63.70.10	HSK-C 63	10	h6	75	24	32	32	42	10	M8x1
C63.70.12	HSK-C 63	12	h6	80	24	32	37	47	10	M10x1
C63.70.14	HSK-C 63	14	h6	80	27	34	37	47	10	M10x1
C63.70.16	HSK-C 63	16	h6	85	27	34	40	50	10	M12x1
C63.70.18	HSK-C 63	18	h6	85	33	42	40	50	10	M12x1
C63.70.20	HSK-C 63	20	h6	90	33	42	42	52	10	M16x1
C63.70.25	HSK-C 63	25	h6	100	44	53	48	58	10	M16x1
C63.70.32	HSK-C 63	32	h6	110	44	53	51	61	10	M16x1

LSCX = Einspannlänge, max.

LSCX = Clamping depth, max.

LSCX = Profondeur d'insertion, max.

ADJRG = Verstellweg, max.

ADJRG = Length adjustment range, max.

ADJRG = Course de réglage, max.

Für Ø 3, 4 und 5 mm nur Hartmetallschäfte verwenden!

For Ø 3, 4 and 5 mm only solid carbide tool shanks must be used!

Pour Ø 3, 4 et 5 mm il faut seulement utiliser de queues d'outils carbures de type HM!

Hinweis: Aufnahme für Induktiv-, Kontakt- und Heißluftschumpfgeräte geeignet.
Schafttoleranz bei Ø 3, 4 und 5 mm = h₄, bei Ø 6 - Ø 32 mm = h₆

Note: Toolholders suitable for induction-, contact- and hot air shrink units.
Ø 3, 4, 5 with h₄-tolerance and Ø 6 - Ø 32 with h₆-tolerance

Observation: Porte-outils convenables pour machines à fretter par induction,
par contact, ou par air chaud.
Ø 3, 4, 5 avec h₄-tolerance et Ø 6 - Ø 32 avec h₆-tolerance



Toolholders DIN 69893-5 - HSK-E
Porte-outils DIN 69893-5 - HSK-E

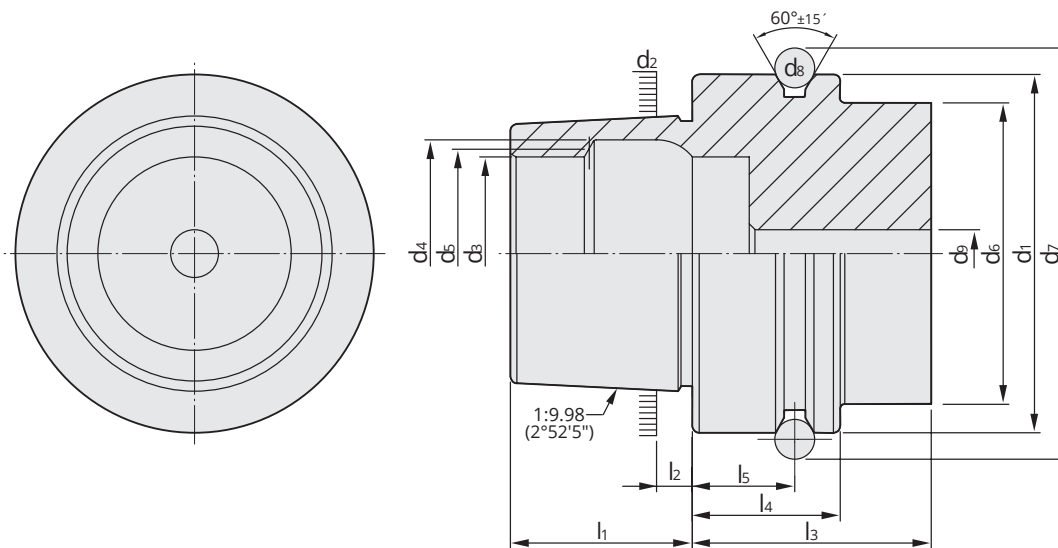

HSK	d ₁ h10	d ₂	d ₃ H10	d ₄ H11	d ₅	d ₆ max	d ₇ 0 -0,1	d ₈	d ₉ max	l ₁ 0 -0,2	l ₂	l ₃ min	l ₄ 0 -0,1	l ₅ ±0,1
25	25	19,006	14	16,4	15	20	28,5	3	3	13	2,5	20	10	4,5
32	32	24,007	17	20,5	19	26	37	4	4,2	16	3,2	35	20	16
40	40	30,007	21	25,5	23	34	45	4	5	20	4	35	20	16
50	50	38,009	26	32	29	42	59,3	7	6,8	25	5	42	26	18
63	63	48,010	34	40	37	53	72,3	7	8,4	32	6,3	42	26	18
80	80	60,012	42	50	46	68	88,8	7	10,2	40	8	42	26	18
100	100	75,013	53	63	58	88	109,75	7	12	50	10	45	29	20
125	125	95,016	67	80	73	111	134,75	7	14	63	12,5	45	29	20

Vorgewuchtet
Pre-balanced
Pré-équilibré

G 6,3 15.000 min⁻¹

G 2,5 Feinwuchten gegen Aufpreis
G 2.5 Fine balancing at extra price
G 2,5 Equilibrage fin contre un supplément

Werkstoff: Legierter Einsatzstahl mit einer Zugfestigkeit im Kern von min. 950 N / mm². Einsatzgehärtet HRC 60 ± 2 (HV 700 ± 50), Härtetiefe 0,8 mm ± 0,2 mm, brüniert und präzisionsgeschliffen.

Genauigkeit: Kegelwinkel – Toleranzqualität < AT 3 nach DIN 7187.

Material: Alloyed case-hardened steel, tensile core strength of min. 950 N / mm². Case hardened HRC 60 ± 2 (HV 700 ± 50), hardening depth 0.8 mm ± 0.2 mm, black-finished and precisely grinded.

Accuracy: Quality of taper < AT 3 according to DIN 7187.

Matière: Acier de cémentation allié. Résistance à la traction dans le noyau de min 950 N / mm². Cémentation à HRC 60 ± 2 (HV 700 ± 50), profondeur de cémentation 0,8 mm ± 0,2 mm, bruni et rectifié précisément.

Précision: Qualité du cône < AT 3 suivant DIN 7187.

Normative Verweise:

DIN 69893-1:2011
Kegel-Hohlschäfte mit Plananlage besteht aus:
- Teil 1: Kegel-Hohlschäfte Form A und Form C;
Maße und Ausführung

Normative references:

DIN 69893-1:2011
Hollow taper shanks with flange contact surface:
- Part 1: Hollow taper shanks type A and type C;
Dimensions and design

Références normatives:

DIN 69893-1:2011
Queues creuses coniques à surface de contact plane:
- Partie 1: Queues creuses coniques type A et type C;
Dimensions et conception

Index
Sommaire

5.69	5.70	5.71	5.72
			
5.74	5.75	5.76	5.77
			
5.79			
			

Collet chucks for collets ISO 15488 (DIN 6499) ER-system
Mandrins à pinces pour pinces ISO 15488 (DIN 6499) système ER



Verwendung:
Zur Aufnahme von Werkzeugen mit Zylinderschaft in Spannzangen.

Application:
For mounting straight-shank tools in collets.

Application:
Destiné à recevoir les outils avec les queues de forme cylindrique dans les pinces de serrage.

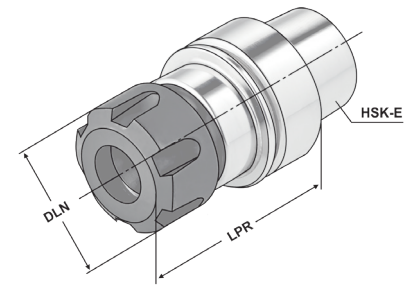

ISO 12164 Form E $\leq 3\mu\text{m}$ G7.5 25.000 min⁻¹ ISO 15488



Bestell-Nr. Order no. Référence	HSK	DCONWS Spannbereich Capacity Capacité	Typ	LPR	DLN	THID
E25.02.10.M ¹	HSK-E 25	1 - 10	426E ER 16 Mini	52	22	M8
E25.02.10	HSK-E 25	1 - 10	426E ER 16	65	28	M10 x 1,5
E25.02.16.M ¹	HSK-E 25	2 - 16	430E ER 25 Mini	70	35	M8
E32.02.07.M ¹	HSK-E 32	1 - 7	4008E ER 11 Mini	60	16	M6x1
E32.02.10.M ¹	HSK-E 32	1 - 10	426E ER 16 Mini	65	22	M5
E32.02.13.M ¹	HSK-E 32	1 - 13	430E ER 25 Mini	75	28	M6
E32.02.16.M ¹	HSK-E 32	2 - 16	430E ER 25 Mini	85	35	M6
E32.02.20	HSK-E 32	2 - 20	470E ER 32	95	50	M16 x 2,0
E40.02.10.M ¹	HSK-E 40	1 - 10	426E ER 16 Mini	100	22	M8
E40.02.10	HSK-E 40	1 - 10	426E ER 16	65	32	M10 x 1,5
E40.02.13	HSK-E 40	1 - 13	428E ER 20	60	35	M12 x 1,75
E40.02.16	HSK-E 40	2 - 16	430E ER 25	75	42	M16 x 2,0
E40.02.20	HSK-E 40	2 - 20	470E ER 32	100	50	M16 x 2,0
E50.02.10	HSK-E 50	1 - 10	426E ER 16	80	28	M10 x 1,5
E50.02.16	HSK-E 50	2 - 16	430E ER 25	80	42	M16 x 2,0
E50.02.20	HSK-E 50	2 - 20	470E ER 32	85	50	M16 x 2,0
E50.02.26	HSK-E 50	3 - 26	472E ER 40	100	63	M16 x 2,0
E63.02.10.1	HSK-E 63	1 - 10	426E ER 16	100	28	M10 x 1,5
E63.02.16	HSK-E 63	2 - 16	430E ER 25	80	42	M16 x 2,0
E63.02.20	HSK-E 63	2 - 20	470E ER 32	90	50	M16 x 2,0
E63.02.26	HSK-E 63	3 - 26	472E ER 40	120	63	M16 x 2,0

¹ Minimutter
¹ Mini nut
¹ Écrous mini

Lieferumfang: Mit gewuchteter Spannmutter
Delivery: With balanced clamping nut
Livraison: Avec écrou de serrage équilibré



für Spannzangen ISO 15488 (DIN 6499) System ER

Precision collet chuck ER for collets ISO 15488 (DIN 6499) ER-system

Mandrin à pinces ER de précision pour pinces ISO 15488 (DIN 6499) système ER



Verwendung:
Zur Aufnahme von Werkzeugen mit Zylinderschaft in 3 µm-Spannzangen.

Application:
For mounting straight-shank tools in 3 µm-collets.

Application:
Pour le serrage d'outils avec queue cylindrique dans des pinces de serrage 3 µm.

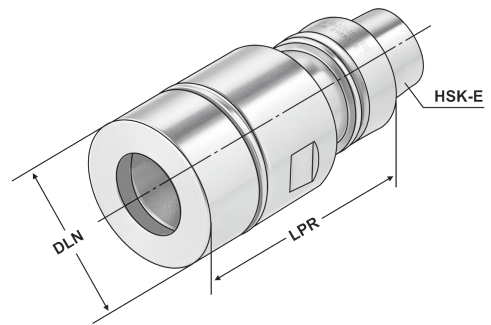

Bestell-Nr. Order no. Référence	HSK	DCONWS Spannbereich Capacity Capacité	Typ	LPR	DLN	THID
E40.P2.20.070	HSK-E 40	2 - 20	470E ER 32	70	50	M16 x 2,0
E50.P2.20.070	HSK-E 50	2 - 20	470E ER 32	70	50	M16 x 2,0

Vorteile:

Exzellente Rundlaufgenauigkeit im System (Futter + Spannzange + Spannmutter)
Extreme Haltekräfte (erhöht die Haltekraft um mindestens 60 % im Vergleich zu Standard ER-Futter)
Glatte Spannmutter ohne Nuten für Hochgeschwindigkeitsbearbeitung

Advantages:

Excellent concentricity in the system (chuck + collet + clamping nut)
Extremely strong holding force (increases the holding power by at least 60% compared to standard ER chuck)
Plain clamping nut without grooves for high speed machining

Avantages:

Excellente précision de concentricité dans le système (mandrin + pince de serrage + écrou de serrage)
La force de maintien extrême (augmente la force de maintien d'au moins à 60% par rapport aux mandrins standards ER)
Écrou de serrage lisse sans rainures pour l'usinage à haute vitesse

Hinweis: Nur das Nennmaß DCONWS kann gespannt werden.

Note: Only nominal size DCONWS can be clamped.

Observation: Seulement la dimension nominale DCONWS peut être serrée.

Lieferumfang: Inklusive Präzisions-Spannmutter
Delivery: With precision clamping nut
Livraison: Avec écrou de serrage de précision



Collet chucks for collets | KPS-system
Mandrins à pinces pour pinces | Système KPS



Verwendung:
Zur Aufnahme von Werkzeugen mit Zylinderschaft in Spannzangen.
Für Anwendungen im HSC-Bereich und für hochpräzise Bearbeitungsergebnisse.

Application:
For mounting straight-shank tools in collets.
To use for high speed cutting and high precision milling.

Utilisation:
Pour la fixation d'outils à queue cylindrique dans les pinces de serrage. Pour l'UGV (Usinage à Grande Vitesse) et pour des résultats d'usinage de haute précision.

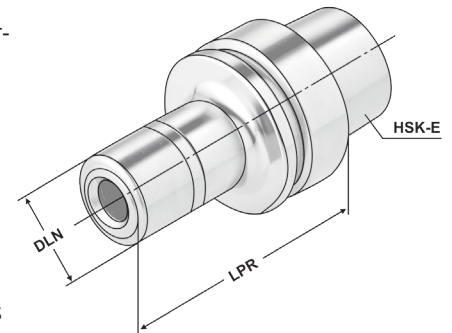

Bestell-Nr. Order no. Référence	HSK	DCONWS Spannbereich Capacity Capacité	Typ	LPR	DLN	THID
E40.03.10	HSK-E 40	1 – 10	490E KPS 10	75	27,5	M12 x 1,75
E40.03.16	HSK-E 40	4 – 16	496E KPS 16	75	40,0	M18 x 1,50
E63.03.10	HSK-E 63	1 – 10	490E KPS 10	105	27,5	M12 x 1,75
E63.03.16	HSK-E 63	4 – 16	496E KPS 16	120	40,0	M18 x 1,50

Lieferumfang: Mit gewuchteter Spannmutter
Delivery: With balanced clamping nut
Livraison: Avec écrou de serrage équilibré



End mill holders DIN 6359 for end mills DIN 1835-B

Porte-fraises DIN 6359 pour queues cylindriques DIN 1835-B

**Verwendung:**

Zum Spannen von zylindrischen Werkzeugschäften mit seitlicher Spannfläche nach DIN 1835 Form B (Weldon).

Application:

For mounting straight-shank tools with lateral flat according to DIN 1835 form B (Weldon).

Application:

Pour le serrage d'outils avec queue cylindrique et avec méplat de serrage latérale suivant DIN 1835 forme B (Weldon).

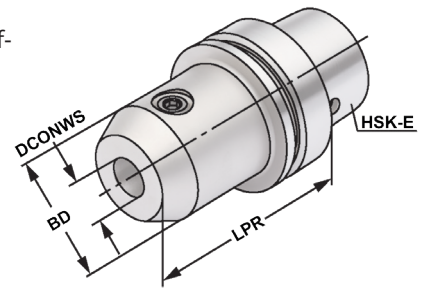

Bestell-Nr. Order no. Référence	HSK	DCONWS	TDCON	LPR	BD
E32.04.06	HSK-E 32	6	H4	60	25
E32.04.08	HSK-E 32	8	H4	60	28
E32.04.10	HSK-E 32	10	H4	65	35
E40.04.06	HSK-E 40	6	H4	60	25
E40.04.08	HSK-E 40	8	H4	60	28
E40.04.10	HSK-E 40	10	H4	60	35
E40.04.12	HSK-E 40	12	H4	70	42
E40.04.14	HSK-E 40	14	H4	75	44
E40.04.16	HSK-E 40	16	H4	75	48
E40.04.20	HSK-E 40	20	H4	75	52
E50.04.06	HSK-E 50	6	H4	65	25
E50.04.08	HSK-E 50	8	H4	65	28
E50.04.10	HSK-E 50	10	H4	65	35
E50.04.12	HSK-E 50	12	H4	80	42
E50.04.14	HSK-E 50	14	H4	80	44
E50.04.16	HSK-E 50	16	H4	80	48
E50.04.18	HSK-E 50	18	H4	80	50
E50.04.20	HSK-E 50	20	H4	80	52
E50.04.25	HSK-E 50	25	H4	102	65
E63.04.06	HSK-E 63	6	H4	65	25
E63.04.08	HSK-E 63	8	H4	65	28
E63.04.10	HSK-E 63	10	H4	65	35
E63.04.12	HSK-E 63	12	H4	80	42
E63.04.14	HSK-E 63	14	H4	80	44
E63.04.16	HSK-E 63	16	H4	80	48
E63.04.18	HSK-E 63	18	H4	80	50
E63.04.20	HSK-E 63	20	H4	80	52
E63.04.25	HSK-E 63	25	H4	110	65
E63.04.32	HSK-E 63	32	H4	110	72
E63.04.40	HSK-E 63	40	H4	120	63

Hinweis: Ab DCONWS = 25 mit zwei Spannschrauben
Note: From DCONWS = 25 on two clamping screws
Observation: A partir de DCONWS = 25 avec deux vis de serrage

Lieferumfang: Mit Spannschraube
Delivery: With clamping screw
Livraison: Avec vis de serrage

End mill holders DIN 6359 for end mills DIN 1835-E

Porte-fraises DIN 6359 pour queues cylindriques DIN 1835-E

**Verwendung:**

Zum Spannen von zylindrischen Werkzeugschäften mit geeigneter Spannfläche nach DIN 1835 Form E (Whistle Notch).

Application:

For mounting straight-shank tools and inclined flat according to DIN 1835 form E (Whistle Notch).

Application:

Pour le serrage d'outils avec queue cylindrique et avec méplat incliné suivant DIN 1835 forme E (Whistle Notch).

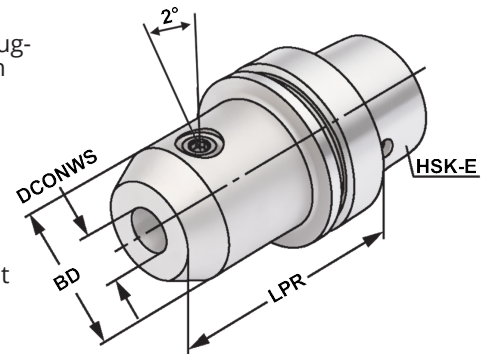

Bestell-Nr. Order no. Référence	HSK	DCONWS	TDCON	LPR	BD
E32.05.06	HSK-E 32	6	H4	60	25
E32.05.08	HSK-E 32	8	H4	80	28
E32.05.10	HSK-E 32	10	H4	80	35
E40.05.06	HSK-E 40	6	H4	60	25
E40.05.08	HSK-E 40	8	H4	80	28
E40.05.10	HSK-E 40	10	H4	80	35
E40.05.12	HSK-E 40	12	H4	90	42
E40.05.14	HSK-E 40	14	H4	90	44
E40.05.16	HSK-E 40	16	H4	90	48
E50.05.06	HSK-E 50	6	H4	80	25
E50.05.08	HSK-E 50	8	H4	80	28
E50.05.10	HSK-E 50	10	H4	80	35
E50.05.12	HSK-E 50	12	H4	90	42
E50.05.14	HSK-E 50	14	H4	90	44
E50.05.16	HSK-E 50	16	H4	90	48
E50.05.18	HSK-E 50	18	H4	90	50
E50.05.20	HSK-E 50	20	H4	100	52
E63.05.06	HSK-E 63	6	H4	80	25
E63.05.08	HSK-E 63	8	H4	80	28
E63.05.10	HSK-E 63	10	H4	80	35
E63.05.12	HSK-E 63	12	H4	90	42
E63.05.14	HSK-E 63	14	H4	90	44
E63.05.16	HSK-E 63	16	H4	100	48
E63.05.18	HSK-E 63	18	H4	100	50
E63.05.20	HSK-E 63	20	H4	100	52
E63.05.25	HSK-E 63	25	H4	110	65
E63.05.32	HSK-E 63	32	H4	110	72

Hinweis: Ab DCONWS = 25 mit zwei Spannschrauben
Note: From DCONWS = 25 on two clamping screws
Observation: A partir de DCONWS = 25 avec deux vis de serrage

Lieferumfang: Mit Spannschraube und axialer Verstellechraube
Delivery: With clamping screw and axial adjustment bolt
Livraison: Avec vis de serrage et vis de butée axiale



mit vergrößerter Anlagefläche

Shell mill holders DIN 6357 with enlarged contact face
 Porte-fraises à trou lisse DIN 6357 avec face de contact élargie



Verwendung:
 Zur Aufnahme von Messerköpfen und Fräsern mit Quernut.
Application:
 For mounting milling cutters with transversal groove.
Application:
 Pour le serrage de fraises à rainure transversale.

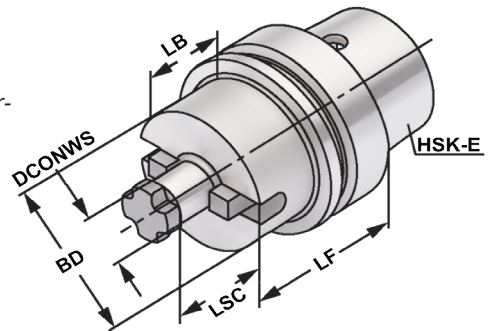

ISO 12164 Form E $\leq 5\mu\text{m}$ G6.3 15.000 min⁻¹ DIN 6357 h6

Bestell-Nr. Order no. Référence	HSK	DCONWS	TCDCON	LF	LSC	LB	BD
E32.11.16	HSK-E 32	16	h6	50	17	30	34
E40.11.16	HSK-E 40	16	h6	50	17	30	34
E40.11.22	HSK-E 40	22	h6	50	19	30	48
E40.11.27	HSK-E 40	27	h6	55	21	35	60
E50.11.16	HSK-E 50	16	h6	50	17	24	38
E50.11.22	HSK-E 50	22	h6	60	19	34	48
E50.11.27	HSK-E 50	27	h6	60	21	34	58
E50.11.32	HSK-E 50	32	h6	60	24	34	65
E63.11.16	HSK-E 63	16	h6	50	17	24	38
E63.11.22	HSK-E 63	22	h6	60	19	34	48
E63.11.27	HSK-E 63	27	h6	60	21	34	58
E63.11.32	HSK-E 63	32	h6	60	24	34	65
E63.11.40	HSK-E 63	40	h6	60	27	34	89

Lieferumfang: Mit Mitnehmersteinen und Kreuzschraube.
Delivery: With drivers and cross head retaining screw.
Livraison: Avec tenons et une vis cruciforme.

Gewuchtete Ausführung

Balanced type
 Type équilibré

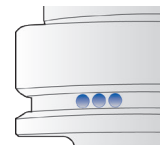

Bestell-Nr. Order no. Référence	Abmessung Size Dimension
---------------------------------------	--------------------------------

- Wuchten auf G 2,5 von vorgewuchteten Kemmler-Werkzeugen**
 Balancing at G 2.5 of pre-balanced Kemmler-tools
 Équilibrage sur G 2,5 d'outils Kemmler pré-équilibrés
- W25 **Ohne Wuchtprotokoll**
 Without balancing report
 Sans protocole d'équilibrage
- W25.2 **Mit Wuchtprotokoll**
 With balancing report
 Avec protocole d'équilibrage

- Wuchten von nicht vorgewuchteten Werkzeugen**
 Balancing of unbalanced tools
 Équilibrage d'outils non-équilibrés
- W25.1 **Ohne Wuchtprotokoll**
 Without balancing report
 Sans protocole d'équilibrage

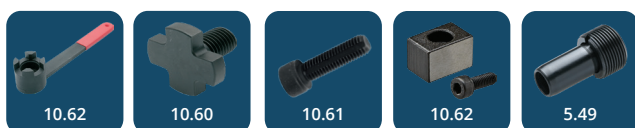

CNC-Drill chucks for clockwise and counter clockwise rotation
Mandrins de perçage CNC pour rotation gauche-droite



Verwendung:
Zur Aufnahme von Werkzeugen mit Zylinderschaft.
Application:
For mounting tools with straight shanks.
Application:
Pour le serrage d'outils avec queue cylindrique.

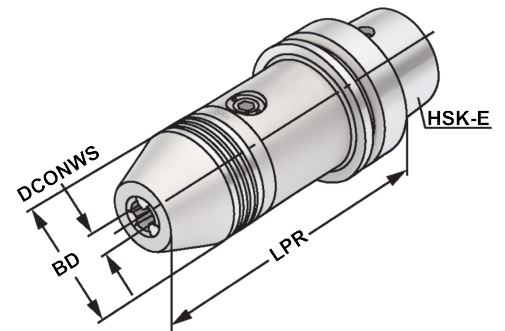

Bestell-Nr. Order no. Référence	HSK	DCONWS Spannbereich Capacity Capacité	LPR	BD	DRVS
E25.15.08	HSK-E 25	0 – 8	70,0	36	4
E32.15.08	HSK-E 32	0 – 8	75,0	36	4
E40.15.08	HSK-E 40	0 – 8	80,0	36	4
E40.15.13	HSK-E 40	1,0 – 13	119,0	50	6
E40.15.16	HSK-E 40	2,5 – 16	124,5	50	6
E50.15.08	HSK-E 50	0 – 8	80	36	4
E50.15.13	HSK-E 50	1,0 – 13	121,0	50	6
E50.15.16	HSK-E 50	2,5 – 16	126,5	50	6
E63.15.13	HSK-E 63	1,0 – 13	123,5	50	6
E63.15.16	HSK-E 63	2,5 – 16	129,0	50	6

Hinweis: Hohe Präzision und Rundlaufgenauigkeit von $\leq 0,03$ mm. Sichere Spannung des Werkzeuges durch mechanische Spannkraftverstärkung. Kein selbständiges Lösen der Spannung während der Bearbeitung bei Links- oder Rechtslauf, sowie bei Spindelstop. Spannen und Lösen mit Sechskantschlüssel.

Note: High precision and accurate concentricity of ≤ 0.03 mm. Secure gripping of the tool through mechanical amplification of the clamping force. No automatic slackening of the clamping force while machining with either clockwise or counter clockwise rotation or on spindle stop. Clamping and releasing effected by means of an Allen wrench.

Observation: Précision élevée et exactitude de circularité de $\leq 0,03$ mm. Serrage sûr de l'outil grâce à l'amplification de la force de serrage. Pas de desserrage intempestif en cours d'usinage lors de la rotation la gauche ou la droite, de même qu'en cas d'arrêt de la broche. Serrage et desserrage en utilisant un clé sur à fourche.

Lieferumfang: Ohne Spannschlüssel
Delivery: Without wrench
Livraison: Sans clé de serrage

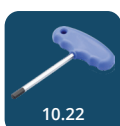

Boring bar blanks
Barres d'alésage

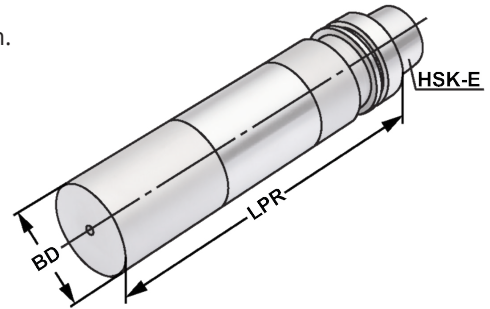

Verwendung:
Zur Herstellung von Sonderwerkzeugen.
Application:
For the manufacturing of special tools.
Application:
Pour la fabrication d'outils spéciaux.

ISO
12164Form
E

Bestell-Nr.
Order no.
Référence

HSK

LPR

BD

E25.17.30

HSK-E 25

40

30,0

E32.17.32

HSK-E 32

100

32,5

E40.17.40

HSK-E 40

125

40,5

E50.17.50

HSK-E 50

125

50,5

E63.17.63

HSK-E 63

250

63,5

Ausführung:

Kegel und Bund gehärtet und geschliffen. Schaft weich zur weiteren Bearbeitung.

Version:

Cone and flange hardened and grinded. Soft body for later processing.

Version:

Cône et collerette durcis et rectifiés. Corps doux pour un usinage ultérieur.



5.49

Hydraulic expansion chucks
Mandrins expansibles hydrauliques



Verwendung:
Zur Aufnahme von Werkzeugen mit Zylinderschaft nach DIN 1835 Form A+B+E und DIN 6535 Form HA+HB+HE (größer Ø 20 mm nur mit Reduzierung).

Application:
For mounting straight-shank tools acc. DIN 1835 form A+B+E and DIN 6535 form HA+HB+HE (larger than dia. 20 mm only with reduction sleeve).

Application:
Pour le serrage d'outils avec queue cylindrique suivant DIN 1835 forme A+B+E et DIN 6535 forme HA+HB+HE.

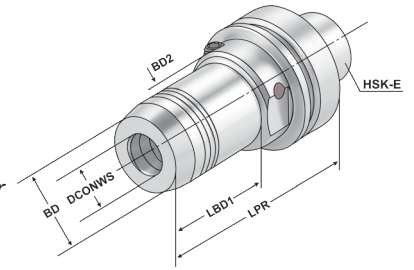

Bestell-Nr. Order no. Référence	HSK	DCONWS	LPR	BD	BD2	LSCX	ADJRG	LBD1	DRVS	THID
E25.H06	HSK-E 25	6	70	26	20	37	10	38	5	M5
E25.H08	HSK-E 25	8	80	28	20	37	10	-	5	M5
E25.H10	HSK-E 25	10	85	30	20	42	10	-	5	M6
E25.H12	HSK-E 25	12	90	32	20	47	10	-	5	M6
E32.H06	HSK-E 32	6	80	26	26	37	10	60	5	M5
E32.H08	HSK-E 32	8	80	28	26	37	10	-	5	M6
E32.H10	HSK-E 32	10	85	30	26	42	10	-	5	M6
E32.H12	HSK-E 32	12	90	32	26	47	10	-	5	M6
E40.H06	HSK-E 40	6	80	26	34	37	10	35	5	M5
E40.H08	HSK-E 40	8	80	28	34	37	10	36	5	M6
E40.H10	HSK-E 40	10	85	30	34	42	10	41	5	M8x1
E40.H12	HSK-E 40	12	90	32	34	47	10	47	5	M8x1
E40.H14	HSK-E 40	14	90	34	34	47	10	70	5	M10x1
E40.H16	HSK-E 40	16	100	38	34	52	10	-	5	M10x1
E40.H20	HSK-E 40	20	100	42	50	52	10	-	5	M12x1
E50.H06	HSK-E 50	6	80	26	42	37	10	54	5	M5
E50.H08	HSK-E 50	8	80	28	42	37	10	54	5	M6
E50.H10	HSK-E 50	10	85	30	42	42	10	59	5	M8x1
E50.H12	HSK-E 50	12	90	32	42	47	10	64	5	M8x1
E50.H14	HSK-E 50	14	90	34	42	47	10	64	5	M10x1
E50.H16	HSK-E 50	16	95	38	42	52	10	69	5	M10x1
E50.H18	HSK-E 50	18	95	40	42	52	10	69	5	M10x1
E50.H20	HSK-E 50	20	100	42	42	52	10	74	5	M10x1

LSCX = Einspannlänge, max.
LSCX = Clamping depth, max.
LSCX = Profondeur d'insertion, max.

ADJRG = Verstellweg, max.
ADJRG = Length adjustment range, max.
ADJRG = Course de réglage, max.

Lieferumfang: Ohne Spannschlüssel
Delivery: Without wrench
Livraison: Sans clé de serrage



Hydraulic expansion chucks
Mandrins expansibles hydrauliques



Verwendung:
Zur Aufnahme von Werkzeugen mit Zylinderschaft nach DIN 1835 Form A+B+E und DIN 6535 Form HA+HB+HE (größer Ø 20 mm nur mit Reduzierung).

Application:
For mounting straight-shank tools acc. DIN 1835 form A+B+E and DIN 6535 form HA+HB+HE (larger than dia. 20 mm only with reduction sleeve).

Application:
Pour le serrage d'outils avec queue cylindrique suivant DIN 1835 forme A+B+E et DIN 6535 forme HA+HB+HE.

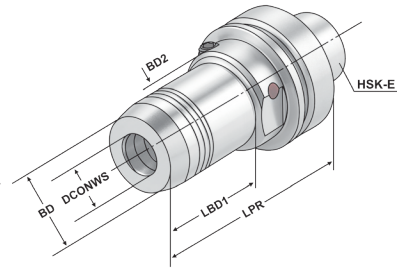

Bestell-Nr. Order no. Référence	HSK	DCONWS	LPR	BD	BD2	LSCX	ADJRGA	LBD1	DRVS	THID
E63.H06	HSK-E 63	6	80	26	50	37	10	33	5	M5
E63.H08	HSK-E 63	8	80	28	50	37	10	33,5	5	M6
E63.H10	HSK-E 63	10	85	30	50	42	10	39	5	M8x1
E63.H12	HSK-E 63	12	90	32	50	47	10	44,5	5	M10x1
E63.H14	HSK-E 63	14	90	34	50	47	10	46	5	M12x1
E63.H16	HSK-E 63	16	95	38	50	52	10	51,5	5	M12x1
E63.H18	HSK-E 63	18	95	40	50	52	10	52	5	M12x1
E63.H20	HSK-E 63	20	100	42	50	52	10	58	5	M12x1
E63.H25	HSK-E 63	25	120	50	50	58	10	59	5	M12x1
E63.H32	HSK-E 63	32	125	60	60	62	10	59	5	M12x1

LSCX = Einspannlänge, max. ADJRGA = Verstellweg, max.
LSCX = Clamping depth, max. ADJRGA = Length adjustment range, max.
LSCX = Profondeur d'insertion, max. ADJRGA = Course de réglage, max.

Lieferumfang: Ohne Spannschlüssel
Delivery: Without wrench
Livraison: Sans clé de serrage



Spannkraft-Prüfgerät für Hydrodehnspannfutter - Seite 12.59
Clamping force proofing instrument for hydraulic chucks - page 12.59
Appareil de contrôle des forces de serrage pour mandrin expansibles hydrauliques - page 12.59



zum Spannen von HM und HSS Werkzeugschäften

Shrink chucks 4,5° for mounting of solid carbide and HSS-tool shanks

Mandrins de frettage 4,5° pour le serrage de queues d'outils carbures de type HM et HSS



Verwendung:
Zur Aufnahme von Werkzeugen mit Zylinderschaft.

Application:
For mounting straight-shank tools.

Application:
Pour le serrage d'outils avec queue cylindrique.

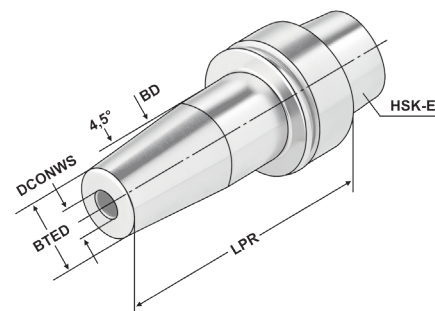

Bestell-Nr. Order no. Référence	HSK	DCONWS	TDCON	LPR	BTED	BD	LSCN	LSCX	ADJRGA	THID
E25.70.03	HSK-E 25	3	h4	40	11	15	5	10	-	-
E25.70.04	HSK-E 25	4	h4	40	16	22	12	20	-	-
E25.70.05	HSK-E 25	5	h4	50	16	22	15	20	-	-
E25.70.06	HSK-E 25	6	h6	50	21	26	18	36	-	-
E25.70.08	HSK-E 25	8	h6	50	21	26	24	36	-	-
E25.70.10	HSK-E 25	10	h6	50	21	26	30	42	-	-
E25.70.12	HSK-E 25	12	h6	50	24	26	34	47	-	-
E32.70.03	HSK-E 32	3	h4	70	11	15	9	10	-	-
E32.70.04	HSK-E 32	4	h4	70	16	22	15	20	5	M3
E32.70.05	HSK-E 32	5	h4	70	16	22	15	20	5	M4
E32.70.06	HSK-E 32	6	h6	70	21	26	26	36	10	M5
E32.70.08	HSK-E 32	8	h6	70	21	26	26	36	10	M6
E32.70.10	HSK-E 32	10	h6	70	24	26	32	42	10	M8x1
E32.70.12	HSK-E 32	12	h6	85	24	26	37	47	10	M10x1
E40.70.03	HSK-E 40	3	h4	80	9	18	10	18	-	-
E40.70.04	HSK-E 40	4	h4	80	10	22	10	20	5	-
E40.70.05	HSK-E 40	5	h4	80	16	22	10	20	5	-
E40.70.06	HSK-E 40	6	h6	80	21	27	26	36	10	M5
E40.70.08	HSK-E 40	8	h6	80	21	27	26	36	10	M6
E40.70.10	HSK-E 40	10	h6	80	24	32	32	42	10	M8x1
E40.70.12	HSK-E 40	12	h6	90	24	32	37	47	10	M8x1
E40.70.14	HSK-E 40	14	h6	90	27	34	37	47	10	M10x1
E40.70.16	HSK-E 40	16	h6	90	27	34	40	50	10	M12x1

LSCX = Einspannlänge, max. ADJRGA = Verstellweg, max.
 LSCX = Clamping depth, max. ADJRGA = Length adjustment range, max.
 LSCX = Profondeur d'insertion, max. ADJRGA = Course de réglage, max.

Hinweis: Aufnahme für Induktiv-, Kontakt- und Heißluftschrimpferäte geeignet. Schafttoleranz bei $\varnothing 3, 4$ und $5\text{ mm} = h_4$, bei $\varnothing 6 - \varnothing 32\text{ mm} = h_6$

Note: Toolholders suitable for induction-, contact- and hot air shrink units. $\varnothing 3, 4, 5$ with h_4 -tolerance and $\varnothing 6 - \varnothing 32$ with h_6 -tolerance

Observation: Porte-outils convenables pour machines à fretter par induction, par contact, ou par air chaud. $\varnothing 3, 4, 5$ avec h_4 -tolerance et $\varnothing 6 - \varnothing 32$ avec h_6 -tolerance

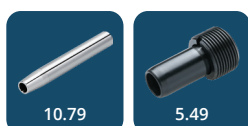

zum Spannen von HM und HSS Werkzeugschäften

Shrink chucks 4,5° for mounting of solid carbide and HSS-tool shanks

Mandrins de frettage 4,5° pour le serrage de queues d'outils carbures de type HM et HSS



Verwendung:
Zur Aufnahme von Werkzeugen mit Zylinderschaft.

Application:
For mounting straight-shank tools.

Application:
Pour le serrage d'outils avec queue cylindrique.

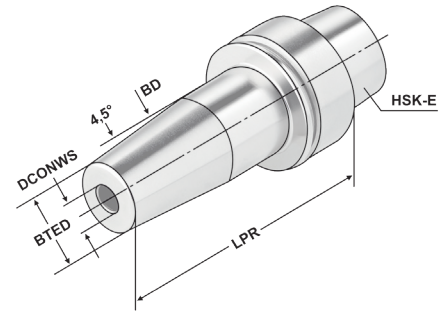

ISO 12164 Form E $\leq 3\mu\text{m}$ G2.5 25.000 min⁻¹ h6

Bestell-Nr. Order no. Référence	HSK	DCONWS	TDCON	LPR	BTED	BD	LSCN	LSCX	ADJRGA	THID
E40.70.06.1	HSK-E 40	6	h6	130	21	27	26	36	10	M5
E40.70.08.1	HSK-E 40	8	h6	130	21	27	26	36	10	M6
E40.70.10.1	HSK-E 40	10	h6	130	24	32	32	42	10	M8x1
E40.70.12.1	HSK-E 40	12	h6	130	24	32	37	47	10	M10x1
E40.70.14.1	HSK-E 40	14	h6	130	27	34	37	47	10	M10x1
E40.70.16.1	HSK-E 40	16	h6	130	27	34	40	50	10	M12x1
E50.70.03	HSK-E 50	3	h4	80	11	15	9	10	-	-
E50.70.04	HSK-E 50	4	h4	80	16	22	15	20	5	M3
E50.70.05	HSK-E 50	5	h4	80	16	22	15	20	5	M4
E50.70.06	HSK-E 50	6	h6	80	21	27	26	36	10	M5
E50.70.08	HSK-E 50	8	h6	80	21	27	26	36	10	M6
E50.70.10	HSK-E 50	10	h6	85	24	32	32	42	10	M8x1
E50.70.12	HSK-E 50	12	h6	90	24	32	37	47	10	M10x1
E50.70.14	HSK-E 50	14	h6	90	27	34	37	47	10	M10x1
E50.70.16	HSK-E 50	16	h6	95	27	34	40	50	10	M12x1
E50.70.18	HSK-E 50	18	h6	95	33	42	40	50	10	M12x1
E50.70.20	HSK-E 50	20	h6	100	33	42	42	52	10	M16x1
E50.70.03.1	HSK-E 50	3	h4	120	11	21	9	10	-	-
E50.70.04.1	HSK-E 50	4	h4	120	14	21	15	20	5	M3
E50.70.05.1	HSK-E 50	5	h4	120	16	24	15	20	5	M4
E50.70.06.1	HSK-E 50	6	h6	120	21	27	26	36	10	M5
E50.70.08.1	HSK-E 50	8	h6	120	21	27	26	36	10	M6
E50.70.10.1	HSK-E 50	10	h6	120	24	32	32	42	10	M8x1
E50.70.12.1	HSK-E 50	12	h6	120	24	32	37	47	10	M10x1
E50.70.14.1	HSK-E 50	14	h6	120	27	34	37	47	10	M10x1
E50.70.16.1	HSK-E 50	16	h6	120	27	34	40	50	10	M12x1
E50.70.18.1	HSK-E 50	18	h6	120	33	42	40	50	10	M12x1
E50.70.20.1	HSK-E 50	20	h6	120	33	42	42	52	10	M16x1

LSCX = Einspannlänge, max. ADJRGA = Verstellweg, max.
 LSCX = Clamping depth, max. ADJRGA = Length adjustment range, max.
 LSCX = Profondeur d'insertion, max. ADJRGA = Course de réglage, max.

Für Ø 3, 4 und 5 mm nur Hartmetallschäfte verwenden!

For Ø 3, 4 and 5 mm only solid carbide tool shanks must be used!

Pour Ø 3, 4 et 5 mm il faut seulement utiliser de queues d'outils carbures de type HM!

Hinweis: Aufnahme für Induktiv-, Kontakt- und Heißluftschumpfergeräte geeignet.
 Schafttoleranz bei Ø 3, 4 und 5 mm = h₄, bei Ø 6 - Ø 32 mm = h₆

Note: Toolholders suitable for induction-, contact- and hot air shrink units.
 Ø 3, 4, 5 with h₄-tolerance and Ø 6 - Ø 32 with h₆-tolerance

Observation: Porte-outils convenables pour machines à frotter par induction,
 par contact, ou par air chaud.
 Ø 3, 4, 5 avec h₄-tolerance et Ø 6 - Ø 32 avec h₆-tolerance

zum Spannen von HM und HSS Werkzeugschäften

Shrink chucks 4,5° for mounting of solid carbide and HSS-tool shanks

Mandrins de frettage 4,5° pour le serrage de queues d'outils carbures de type HM et HSS



Verwendung:
Zur Aufnahme von Werkzeugen mit Zylinderschaft.

Application:
For mounting straight-shank tools.

Application:
Pour le serrage d'outils avec queue cylindrique.

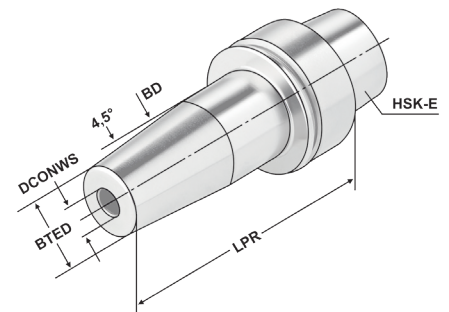

Bestell-Nr. Order no. Référence	HSK	DCONWS	TDCON	LPR	BTED	BD	LSCN	LSCX	ADJRGA	THID
E50.70.03.2	HSK-E 50	3	h4	160	11	21	9	10	-	-
E50.70.04.2	HSK-E 50	4	h4	160	14	21	15	20	5	M3
E50.70.05.2	HSK-E 50	5	h4	160	16	24	15	20	5	M4
E50.70.06.2	HSK-E 50	6	h6	160	21	27	26	36	10	M5
E50.70.08.2	HSK-E 50	8	h6	160	21	27	26	36	10	M6
E50.70.10.2	HSK-E 50	10	h6	160	24	32	31	41	10	M8x1
E50.70.12.2	HSK-E 50	12	h6	160	24	32	37	47	10	M10x1
E50.70.14.2	HSK-E 50	14	h6	160	27	34	37	47	10	M10x1
E50.70.16.2	HSK-E 50	16	h6	160	27	34	40	50	10	M12x1
E50.70.18.2	HSK-E 50	18	h6	160	33	42	40	50	10	M12x1
E50.70.20.2	HSK-E 50	20	h6	160	33	42	42	52	10	M16x1
E63.70.03	HSK-E 63	3	h4	80	11	15	9	10	-	-
E63.70.04	HSK-E 63	4	h4	80	14	22	15	20	5	M3
E63.70.05	HSK-E 63	5	h4	80	16	22	15	20	5	M4
E63.70.06	HSK-E 63	6	h6	80	21	27	26	36	10	M5
E63.70.08	HSK-E 63	8	h6	80	21	27	26	36	10	M6
E63.70.10	HSK-E 63	10	h6	85	24	32	31	41	10	M8x1
E63.70.12	HSK-E 63	12	h6	90	24	32	37	47	10	M10x1
E63.70.14	HSK-E 63	14	h6	90	27	34	37	47	10	M10x1
E63.70.16	HSK-E 63	16	h6	95	27	34	40	50	10	M12x1
E63.70.18	HSK-E 63	18	h6	95	33	42	40	50	10	M12x1
E63.70.20	HSK-E 63	20	h6	100	33	42	42	52	10	M16x1
E63.70.25	HSK-E 63	25	h6	115	44	53	48	58	10	M16x1
E63.70.32	HSK-E 63	32	h6	120	44	53	52	62	10	M20x1

LSCX = Einspannlänge, max.
LSCX = Clamping depth, max.
LSCX = Profondeur d'insertion, max.

ADJRGA = Verstellweg, max.
ADJRGA = Length adjustment range, max.
ADJRGA = Course de réglage, max.

Für Ø 3, 4 und 5 mm nur Hartmetallschäfte verwenden!

For Ø 3, 4 and 5 mm only solid carbide tool shanks must be used!

Pour Ø 3, 4 et 5 mm il faut seulement utiliser de queues d'outils carbures de type HM!

Hinweis: Aufnahme für Induktiv-, Kontakt- und Heißluftschumpfgeräte geeignet. Schafttoleranz bei Ø 3, 4 und 5 mm = h₄, bei Ø 6 – Ø 32 mm = h₆

Note: Toolholders suitable for induction-, contact- and hot air shrink units. Ø 3, 4, 5 with h₄-tolerance and Ø 6 – Ø 32 with h₆-tolerance

Observation: Porte-outils convenables pour machines à frotter par induction, par contact, ou par air chaud. Ø 3, 4, 5 avec h₄-tolerance et Ø 6 – Ø 32 avec h₆-tolerance

zum Spannen von HM und HSS Werkzeugschäften

Shrink chucks 4,5° for mounting of solid carbide and HSS-tool shanks

Mandrins de frettage 4,5° pour le serrage de queues d'outils carbures de type HM et HSS



Verwendung:
Zur Aufnahme von Werkzeugen mit Zylinderschaft.

Application:
For mounting straight-shank tools.

Application:
Pour le serrage d'outils avec queue cylindrique.

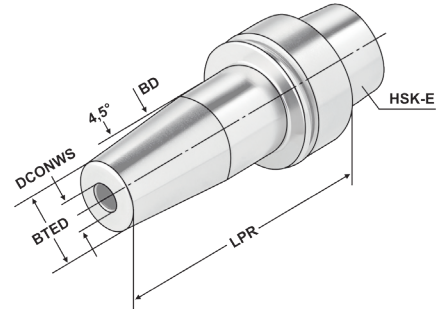

Bestell-Nr. Order no. Référence	HSK	DCONWS	TDCON	LPR	BTED	BD	LSCN	LSCX	ADJRGA	THID
E63.70.04.1	HSK-E 63	4	h4	120	14	21	15	20	5	M3
E63.70.06.1	HSK-E 63	6	h6	120	21	27	26	36	10	M5
E63.70.08.1	HSK-E 63	8	h6	120	21	27	26	36	10	M6
E63.70.10.1	HSK-E 63	10	h6	120	24	32	31	41	10	M8x1
E63.70.12.1	HSK-E 63	12	h6	120	24	32	37	47	10	M10x1
E63.70.16.1	HSK-E 63	16	h6	120	27	34	40	50	10	M12x1
E63.70.03.2	HSK-E 63	3	h4	160	11	21	9	10	-	-
E63.70.04.2	HSK-E 63	4	h4	160	14	21	5	20	5	M3
E63.70.06.2	HSK-E 63	6	h6	160	21	27	26	36	10	M5
E63.70.08.2	HSK-E 63	8	h6	160	21	27	26	36	10	M6
E63.70.10.2	HSK-E 63	10	h6	160	24	32	31	41	10	M8x1
E63.70.12.2	HSK-E 63	12	h6	160	24	32	37	47	10	M10x1
E63.70.16.2	HSK-E 63	16	h6	160	27	34	40	50	10	M12x1
E63.70.18.2	HSK-E 63	18	h6	160	33	42	40	50	10	M12x1
E63.70.20.2	HSK-E 63	20	h6	160	33	42	42	52	10	M16x1
E63.70.25.2	HSK-E 63	25	h6	160	44	42	48	58	10	M16x1

LSCX = Einspannlänge, max.

LSCX = Clamping depth, max.

LSCX = Profondeur d'insertion, max.

ADJRGA = Verstellweg, max.

ADJRGA = Length adjustment range, max.

ADJRGA = Course de réglage, max.

Für Ø 3, 4 und 5 mm nur Hartmetallschäfte verwenden!

For Ø 3, 4 and 5 mm only solid carbide tool shanks must be used!

Pour Ø 3, 4 et 5 mm il faut seulement utiliser de queues d'outils carbures de type HM!

Hinweis: Aufnahme für Induktiv-, Kontakt- und Heißluftschumpfergeräte geeignet. Schafttoleranz bei Ø 3, 4 und 5 mm = h₄, bei Ø 6 – Ø 32 mm = h₆

Note: Toolholders suitable for induction-, contact- and hot air shrink units. Ø 3, 4, 5 with h₄-tolerance and Ø 6 – Ø 32 with h₆-tolerance

Observation: Porte-outils convenables pour machines à fretter par induction, par contact, ou par air chaud. Ø 3, 4, 5 avec h₄-tolerance et Ø 6 – Ø 32 avec h₆-tolerance

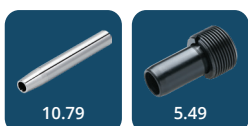

Toolholders formerly DIN 69893-6 - HSK-F
 Porte-outils DIN 69893-6 - HSK-F

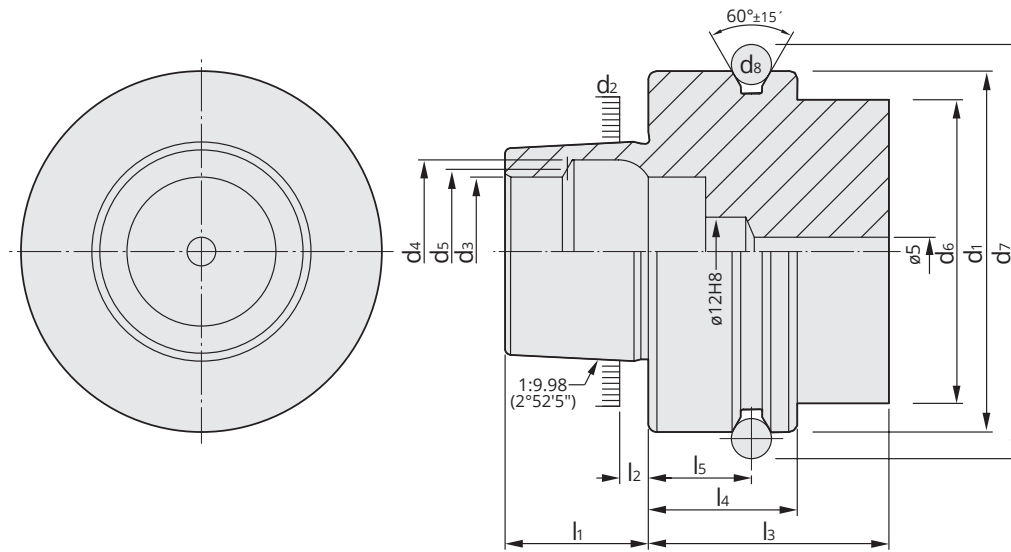

HSK	d ₁	d ₂	d ₃	d ₄	d ₅	d ₆	d ₇	d ₈	l ₁	l ₂	l ₃	l ₄	l ₅
	h10		H10	H11		max	⁰ _{-0,1}		⁰ _{-0,2}		min	⁰ _{-0,1}	±0,1
50	50	30,007	21	25,5	23	42	59,3	7	20	4	42	26	18
63	63	38,009	26	32	29	53	72,3	7	25	5	42	26	18

Vorgewuchtet G 6,3 15.000 min⁻¹
Pre-balanced
 Pré-équilibré

G 2,5 Feinwuchten gegen Aufpreis
G 2.5 Fine balancing at extra charge
 G 2,5 Equilibrage fin contre un supplément

Werkstoff: Legierter Einsatzstahl mit einer Zugfestigkeit im Kern von min. 950 N / mm².
 Einsatzgehärtet HRC 60 ± 2 (HV 700 ± 50), Härtetiefe 0,8 mm ± 0,2 mm

Genauigkeit: Kegelwinkel – Toleranzqualität < AT 3 nach DIN 7187.

Material: Alloyed case-hardened steel, tensile core strength of min. 950 N / mm².
 Case hardened HRC 60 ± 2 (HV 700 ± 50), hardening depth 0.8 mm ± 0.2 mm

Accuracy: Quality of taper < AT 3 according to DIN 7187.

Matière: Acier de cémentation allié. Résistance à la traction dans le noyau de min 950 N / mm².
 Cémentation à HRC 60 ± 2 (HV 700 ± 50), profondeur de cémentation 0,8 mm ± 0,2 mm

Précision: Qualité du cône < AT 3 suivant DIN 7187.

Normative Verweise:

DIN 69893-1:2011
 Kegel-Hohlschäfte mit Plananlage besteht aus:
 - Teil 6: Kegel-Hohlschäfte Form F
 Maße und Ausführung

Normative references:

DIN 69893-1:2011
 Hollow taper shanks with flange contact surface:
 - Part 1: Part 6: Hollow taper shank type F;
 Dimensions and design

Références normatives:

DIN 69893-1:2011
 Queues creuses coniques à surface de contact plane:
 - Partie 1: Queues creuses coniques type A et type C;
 Dimensions et conception

Index
Sommaire

5.85



5.86



5.87



5.88



5.89



5.91



5.92



5.93



5.94



5.95



5.96



5.97



5.99



Collet chucks for collets ISO 10897 (DIN 6388) OZ-system
Mandrins à pinces pour pinces ISO 10897 (DIN 6388) système OZ



Verwendung:
Zur Aufnahme von Werkzeugen mit Zylinderschaft in Spannzangen.

Application:
For mounting straight-shank tools in collets.

Application:
Destiné à recevoir les outils avec les queues de forme cylindrique dans les pinces de serrage.

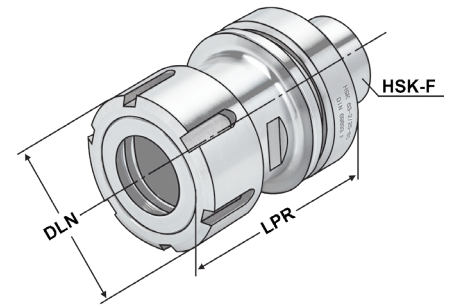

Bestell-Nr. Order no. Référence	HSK	DCONWS Spannbereich Capacity Capacité	Typ	LPR	DLN	DRVS
F63.01.25	HSK-F 63	2 – 25	462E OZ 25	85	60	44

Lieferumfang: Mit gewichteter Spannmutter
Delivery: With balanced clamping nut
Livraison: Avec écrou de serrage équilibré

Gewuchtete Ausführung



Balanced type Type équilibré

Bestell-Nr. Order no. Référence	Abmessung Size Dimension
---------------------------------------	--------------------------------

Wuchten auf G 2,5 von vorgewuchteten Kemmler-Werkzeugen

Balancing at G 2.5 of pre-balanced Kemmler-tools
Équilibrage sur G 2,5 d'outils Kemmler pré-équilibrés

W25 **Ohne Wuchtprotokoll**
Without balancing report
Sans protocole d'équilibrage

W25.2 **Mit Wuchtprotokoll**
With balancing report
Avec protocole d'équilibrage

Wuchten von nicht vorgewuchteten Werkzeugen Balancing of unbalanced tools Équilibrage d'outils non-équilibrés

W25.1 **Ohne Wuchtprotokoll**
Without balancing report
Sans protocole d'équilibrage



Collet chucks for collets ISO 15488 (DIN 6499) ER-system
Mandrins à pinces pour pinces ISO 15488 (DIN 6499) système ER



Verwendung:
Zur Aufnahme von Werkzeugen mit Zylinderschaft in Spannzangen.

Application:
For mounting straight-shank tools in collets.

Application:
Destiné à recevoir les outils avec les queues de forme cylindrique dans les pinces de serrage.

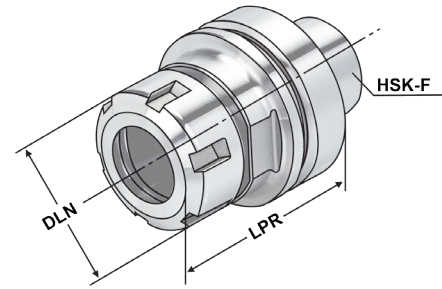

ISO 12164 Form F $\leq 3\mu\text{m}$ G2.5 25,000 min⁻¹ ISO 15488

13.04

Bestell-Nr. Order no. Référence	HSK	DCONWS Spannbereich Capacity Capacité	Typ	LPR	DLN	THID	DRVS
F40.02.10 ¹	HSK-F 40	1 – 10	426E ER 16	60	28	M10 x 1,5	24
F40.02.16	HSK-F 40	2 – 16	430E ER 25	60	42	M16 x 2,0	27
F50.02.16	HSK-F 50	2 – 16	430E ER 25	70	42	M16 x 2,0	36
F50.02.20	HSK-F 50	2 – 20	470E ER 32	80	50	M16 x 2,0	36
F50.02.26	HSK-F 50	3 – 26	472E ER 40	80	63	M16 x 2,0	46
F63.02.10	HSK-F 63	1 – 10	426E ER 16	60	32	M10 x 1,5	27
F63.02.16	HSK-F 63	2 – 16	430E ER 25	70	42	M16 x 2,0	38
F63.02.20	HSK-F 63	2 – 20	470E ER 32	70	50	M16 x 2,0	46
F63.02.26	HSK-F 63	3 – 26	472E ER 40	75	63	M16 x 2,0	46
F63.02.10.1	HSK-F 63	1 – 10	426E ER 16	100	32	M10 x 1,5	27
F63.02.16.1	HSK-F 63	2 – 16	430E ER 25	100	42	M16 x 2,0	38
F63.02.20.1	HSK-F 63	2 – 20	470E ER 32	100	50	M16 x 2,0	46
F63.02.26.1	HSK-F 63	3 – 26	472E ER 40	100	63	M16 x 2,0	46
F63.02.10.2	HSK-F 63	1 – 10	426E ER 16	160	32	M10 x 1,5	27
F63.02.16.2	HSK-F 63	2 – 16	430E ER 25	160	42	M16 x 2,0	38
F63.02.20.2	HSK-F 63	2 – 20	470E ER 32	160	50	M16 x 2,0	46
F63.02.26.2	HSK-F 63	3 – 26	472E ER 40	160	63	M16 x 2,0	46

¹ Sechskantmutter
¹ Hexagonal clamping nut
¹ Écrous hexagonal

Lieferumfang: Mit gewuchteter Spannmutter
Delivery: With balanced clamping nut
Livraison: Avec écrou de serrage équilibré



für Spannzangen ISO 15488 (DIN 6499) System ER

Precision collet chuck ER for collets ISO 15488 (DIN 6499) ER-system

Mandrin à pinces ER de précision pour pinces ISO 15488 (DIN 6499) système ER



Verwendung:

Zur Aufnahme von Werkzeugen mit Zylinderschaft in 3 µm-Spannzangen.

Application:

For mounting straight-shank tools in 3 µm-collets.

Application:

Pour le serrage d'outils avec queue cylindrique dans des pinces de serrage 3 µm.

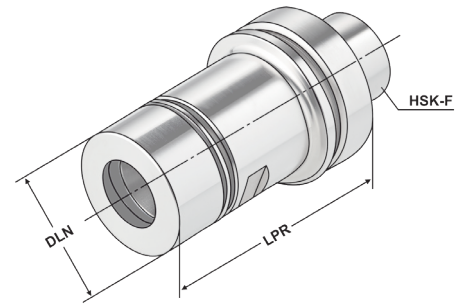

ISO 12164 Form F $\leq 3\mu\text{m}$ G2.5 25.000 min⁻¹ ISO 15488

13.04

Bestell-Nr. Order no. Référence	HSK	DCONWS Spannbereich Capacity Capacité	Typ	LPR	LB	DLN	DRVS	THID
F63.P2.20.100	HSK-F 63	2 – 20	470E ER 32	100	71	50	48	M16 x 2,0

Vorteile:

Exzellente Rundlaufgenauigkeit im System (Futter + Spannzange + Spannmutter)
 Extreme Haltekraften (erhöht die Haltekraft um mindestens 60 % im Vergleich zu Standard ER-Futter)
 Glatte Spannmutter ohne Nuten für Hochgeschwindigkeitsbearbeitung

Advantages:

Excellent concentricity in the system (chuck + collet + clamping nut)
Extremely strong holding force (increases the holding power by at least 60% compared to standard ER chuck)
Plain clamping nut without grooves for high speed machining

Avantages:

Excellente précision de concentricité dans le système (mandrin + pince de serrage + écrou de serrage)
 La force de maintien extrême (augmente la force de maintien d'au moins à 60% par rapport aux mandrins standards ER)
 Écrou de serrage lisse sans rainures pour l'usinage à haute vitesse

Hinweis: Nur das Nennmaß DCONWS kann gespannt werden.

Note: *Only nominal size DCONWS can be clamped.*

Observation: Seulement la dimension nominale DCONWS peut être serrée.

Lieferumfang: Inklusive Präzisions-Spannmutter
Delivery: With precision clamping nut
Livraison: Avec écrou de serrage de précision



Collet chucks for collets | KPS-system

Mandrins à pinces pour pinces | Système KPS

**Verwendung:**

Zur Aufnahme von Werkzeugen mit Zylinderschaft in Spannzangen.
Für Anwendungen im HSC-Bereich und für hochpräzise Bearbeitungsergebnisse.

Application:

For mounting straight-shank tools in collets.
To use for high speed cutting and high precision milling.

Utilisation:

Pour la fixation d'outils à queue cylindrique dans les pinces de serrage. Pour l'UGV (Usinage à Grande Vitesse) et pour des résultats d'usinage de haute précision.

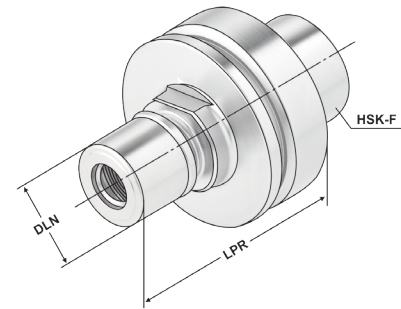

Bestell-Nr. Order no. Référence	HSK	DCONWS Spannbereich Capacity Capacité	Typ	LPR	DLN	DRVS	THID
F63.03.10	HSK-F 63	1 - 10	490EK KPS 10	90	27,5	26	M12 x 1,75
F63.03.16	HSK-F 63	1 - 10	496EK KPS 16	90	27,5	38	M12 x 1,75

Lieferumfang: Mit gewuchteter Spannmutter
Delivery: With balanced clamping nut
Livraison: Avec écrou de serrage équilibré

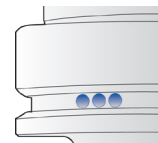
Gewuchtete Ausführung**Balanced type
Type équilibré**

Bestell-Nr. Order no. Référence	Abmessung Size Dimension
---------------------------------------	--------------------------------

**Wuchten auf G 2,5 von vorgewuchteten
Kemmler-Werkzeugen**

Balancing at G 2.5 of pre-balanced Kemmler-tools
Équilibrage sur G 2,5 d'outils Kemmler pré-équilibrés

W25

Ohne Wuchtprotokoll
Without balancing report
Sans protocole d'équilibrage

W25.2

Mit Wuchtprotokoll
With balancing report
Avec protocole d'équilibrage

Wuchten von nicht vorgewuchteten Werkzeugen
Balancing of unbalanced tools
Équilibrage d'outils non-équilibrés

W25.1

Ohne Wuchtprotokoll
Without balancing report
Sans protocole d'équilibrage



End mill holders DIN 6359 for end mills DIN 1835-B

Porte-fraises DIN 6359 pour queues cylindriques DIN 1835-B

**Verwendung:**

Zum Spannen von zylindrischen Werkzeugschäften mit seitlicher Spannfläche nach DIN 1835 Form B (Weldon).

Application:

For mounting straight-shank tools with lateral flat according to DIN 1835 form B (Weldon).

Application:

Pour le serrage d'outils avec queue cylindrique et avec méplat de serrage latérale suivant DIN 1835 forme B (Weldon).

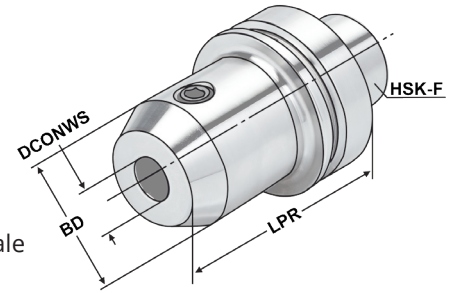

Bestell-Nr. Order no. Référence	HSK	DCONWS	TDCON	LPR	BD
F63.04.06	HSK-F 63	6	H4	65	25
F63.04.08	HSK-F 63	8	H4	65	28
F63.04.10	HSK-F 63	10	H4	65	35
F63.04.12	HSK-F 63	12	H4	80	42
F63.04.14	HSK-F 63	14	H4	80	44
F63.04.16	HSK-F 63	16	H4	80	48
F63.04.18	HSK-F 63	18	H4	80	48
F63.04.20	HSK-F 63	20	H4	80	52
F63.04.25	HSK-F 63	25	H4	110	65
F63.04.32	HSK-F 63	32	H4	110	72

Hinweis: Ab DCONWS = 25 mit zwei Spannschrauben
Note: From DCONWS = 25 on two clamping screws
Observation: A partir de DCONWS = 25 avec deux vis de serrage

Lieferumfang: Mit Spannschraube
Delivery: With clamping screw
Livraison: Avec vis de serrage



End mill holders DIN 6359 for end mills DIN 1835-E
 Porte-fraises DIN 6359 pour queues cylindriques DIN 1835-E



Verwendung:
 Zum Spannen von zylindrischen
 Werkzeugschäften mit geneigter Spannflä-
 che nach DIN 1835 Form E (Whistle Notch).

Application:
 For mounting straight-shank tools and
 inclined flat according to DIN 1835 form E
 (Whistle Notch).

Application:
 Pour le serrage d'outils avec queue
 cylindrique et avec méplat incliné suivant
 DIN 1835 forme E (Whistle Notch).

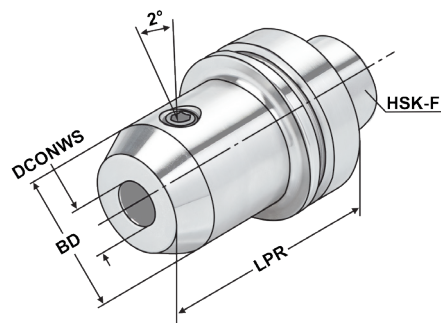

ISO 12164 Form F $\leq 3\mu\text{m}$ G2.5 25.000 min⁻¹ DIN 1835-E H4



Bestell-Nr. Order no. Référence	HSK	DCONWS	TDCON	LPR	BD
F63.05.06	HSK-F 63	6	H4	100	25
F63.05.08	HSK-F 63	8	H4	100	28
F63.05.10	HSK-F 63	10	H4	100	35
F63.05.12	HSK-F 63	12	H4	100	42
F63.05.14	HSK-F 63	14	H4	100	44
F63.05.16	HSK-F 63	16	H4	100	48
F63.05.18	HSK-F 63	18	H4	100	48
F63.05.20	HSK-F 63	20	H4	100	52
F63.05.25	HSK-F 63	25	H4	120	65
F63.05.32	HSK-F 63	32	H4	120	72

Hinweis: Ab DCONWS = 25 mit zwei Spannschrauben
Note: From DCONWS = 25 on two clamping screws
Observation: A partir de DCONWS = 25 avec deux vis de serrage

Lieferumfang: Mit Spannschraube und axialer Verstelle schraube
Delivery: With clamping screw and axial adjustment bolt
Livraison: Avec vis de serrage et vis de butée axiale

Gewuchtete Ausführung



Balanced type
 Type équilibré

Bestell-Nr. Order no. Référence	Abmessung Size Dimension
Wuchten auf G 2,5 von vorgewuchteten Kemmler-Werkzeugen Balancing at G 2.5 of pre-balanced Kemmler-tools Equilibrage sur G 2,5 d'outils Kemmler pré-équilibrés	
W25	Ohne Wuchtprotokoll Without balancing report Sans protocole d'équilibrage
W25.2	Mit Wuchtprotokoll With balancing report Avec protocole d'équilibrage
Wuchten von nicht vorgewuchteten Werkzeugen Balancing of unbalanced tools Equilibrage d'outils non-équilibrés	
W25.1	Ohne Wuchtprotokoll Without balancing report Sans protocole d'équilibrage



mit vergrößerter Anlagefläche

Shell mill holders DIN 6357 with enlarged contact face
 Porte-fraises à trou lisse DIN 6357 avec face de contact élargie



Verwendung:
 Zur Aufnahme von Messerköpfen und Fräsern mit Quernut.

Application:
 For mounting milling cutters with transversal groove.

Application:
 Destiné à recevoir les fraises et les fraises avec des rainures transversales.

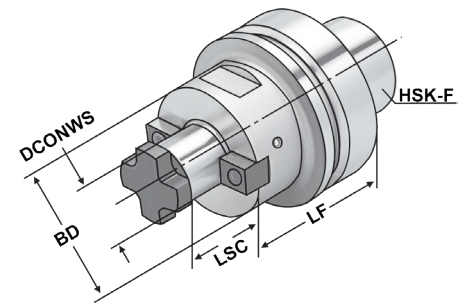

ISO 12164 Form F $\leq 5\mu\text{m}$ G2.5 25.000 min⁻¹ DIN 6357 h6 13.04

Bestell-Nr. Order no. Référence	HSK	DCONWS	TCDCON	LF	LSC	BD	DRVS
F63.11.16	HSK-F 63	16	h6	50	17	40	34
F63.11.22	HSK-F 63	22	h6	50	19	48	44
F63.11.27	HSK-F 63	27	h6	60	21	60	54
F63.11.32	HSK-F 63	32	h6	60	24	78	74
F63.11.40	HSK-F 63	40	h6	100	27	89	84
F63.11.16.1	HSK-F 63	16	h6	100	17	40	34
F63.11.22.1	HSK-F 63	22	h6	100	19	48	44
F63.11.27.1	HSK-F 63	27	h6	100	21	60	54
F63.11.32.1	HSK-F 63	32	h6	100	24	78	74
F63.11.16.2	HSK-F 63	16	h6	160	17	40	34
F63.11.22.2	HSK-F 63	22	h6	160	19	48	44
F63.11.27.2	HSK-F 63	27	h6	160	21	60	54

DCONWS = 40 Für große Planfräser mit vier zusätzlichen Gewindebohrungen nach DIN 2079.
 For large diameter face mill cutters with four additional threaded holes according to DIN 2079.
 Pour fraises à surfacer à grands diamètres avec 4 taraudages supplémentaires suivant DIN 2079.

Lieferumfang: Mit Mitnehmersteinen, Kreuzschraube und Zylinderkopfschraube nach DIN 912 für Fräser mit innerer Kühlmittelzufuhr.
Delivery: With drivers, cross head retaining screw and cylinder head retaining screw for cutters with central coolant.
Livraison: Avec tenon d'entraînement, vis cruciforme et vis à têtes cylindrique suivant DIN 912 pour les fraises avec arrosage central.



CNC-Drill chucks for clockwise and counter clockwise rotation
Mandrins de perçage CNC pour rotation gauche-droite



Verwendung:
 Zur Aufnahme von Werkzeugen mit Zylinderschaft.

Application:
 For mounting tools with straight shanks.

Application:
 Pour le serrage d'outils avec queue cylindrique.

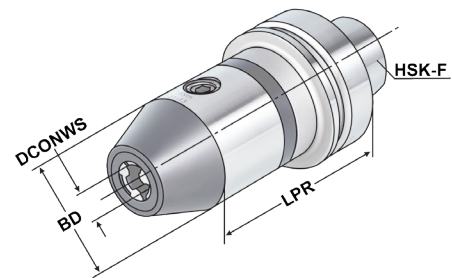

Bestell-Nr. Order no. Référence	HSK	DCONWS Spannbereich Capacity Capacité	LPR	BD	DRVS
F63.15.13	HSK-F 63	1,0 – 13	110	50	6
F63.15.16	HSK-F 63	2,5 – 16	115	50	6

Hinweis: Hohe Präzision und Rundlaufgenauigkeit von $\leq 0,03$ mm. Sichere Spannung des Werkzeuges durch mechanische Spannkraftverstärkung. Kein selbständiges Lösen der Spannung während der Bearbeitung bei Links- oder Rechtslauf, sowie bei Spindelstop. Spannen und Lösen mit Sechskantschlüssel.

Note: *High precision and accurate concentricity of ≤ 0.03 mm. Secure gripping of the tool through mechanical amplification of the clamping force. No automatic slackening of the clamping force while machining with either clockwise or counter clockwise rotation or on spindle stop. Clamping and releasing effected by means of an Allen wrench.*

Observation: Précision élevée et exactitude de circularité de $\leq 0,03$ mm. Serrage sûr de l'outil grâce à l'amplification de la force de serrage. Pas de desserrage intempestif en cours d'usinage lors de la rotation la gauche ou la droite, de même qu'en cas d'arrêt de la broche. Serrage et desserrage en utilisant un clé sur à fourche.

Lieferumfang: Ohne Spannschlüssel
Delivery: Without wrench
Livraison: Sans clé de serrage



mit Längenausgleich auf Druck und Zug

Quick change tapping chucks with length compensation on compression and expansion

Mandrins de taraudage à changement rapide avec compensation longitudinale à la compression et traction



Verwendung:

Zur Aufnahme von Schnellwechsel-Einsätzen für Gewindebohrer.

Application:

For the chucking of quick change adaptors for taps.

Application:

Pour le serrage d'adapteurs porte-tarands à changement rapide.

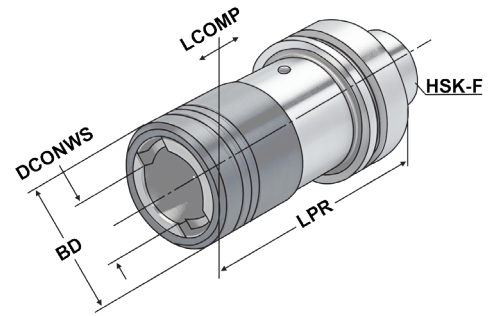

Bestell-Nr. Order no. Référence	HSK	Spannbereich Capacity Capacité	SZID	DCONWS	LPR	BD	LCOMP
F63.16.12	HSK-F 63	M3 - M14	1	19	102	36	7
F63.16.20	HSK-F 63	M5 - M22	2	31	140	53	12

Hinweis: Für Bearbeitungszentren ohne Synchronspindel.
Note: For machining centres without synchronous spindle.
Observation: Pour centres d'usinage sans broche synchrone.



Adaptor sleeves for MT with tang DIN 6383
 Douilles de réduction pour CM à tenon DIN 6383



Verwendung:
 Zur Aufnahme von Werkzeugen mit Morsekegelschaft und Austreibblappen nach DIN 228-1 Form B.

Application:
 For mounting tools with Morse taper shank and tang according to DIN 228-1 form B.

Application:
 Pour le serrage d'outils avec queue cône Morse et tenon suivant DIN 228-1 forme B.

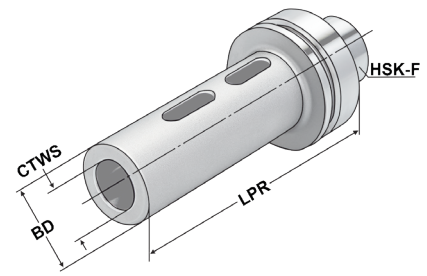

ISO
12164

Form
F

$\leq 5\mu\text{m}$

G6.3
 15.000
 min⁻¹

DIN
6383

AT5

Bestell-Nr. Order no. Référence	HSK	CTWS	TDCON	LPR	BD
F63.07.01	HSK-F 63	1	AT5	100	25
F63.07.02	HSK-F 63	2	AT5	120	32
F63.07.03	HSK-F 63	3	AT5	140	40
F63.07.04	HSK-F 63	4	AT5	160	48



Boring bar blanks
Barres d'alésage



Verwendung:
Zur Herstellung von Sonderwerkzeugen.

Application:
For the manufacturing of special tools.

Application:
Pour la fabrication d'outils spéciaux.

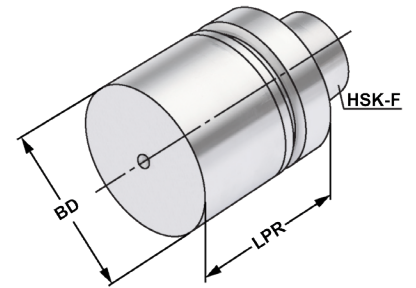

ISO
12164

Form
F

Bestell-Nr. Order no. Référence	HSK	LPR	BD
F63.17.63	HSK-F 63	125	63
F63.17.63.1	HSK-F 63	250	63

Ausführung: Kegel und Bund gehärtet und geschliffen. Schaft weich zur weiteren Bearbeitung.
Version: *Cone and flange hardened and adjusted. Soft body for later processing.*
Version: Cône et collerette durcis et rectifiés. Corps doux pour un usinage ultérieur.

Test arbors
Mandrins de contrôle



Verwendung:
Zur Abnahme von Werkzeugmaschinen gemäß ISO-Empfehlung R230 oder zur Überprüfung der Werkzeugspindel.

Application:
For the inspection of machine tools according to ISO recommendation R230 or for testing the tool spindle.

Application:
Pour l'inspection de machine-outils suite à la recommandation ISO R230 ou pour la vérification de la broche.

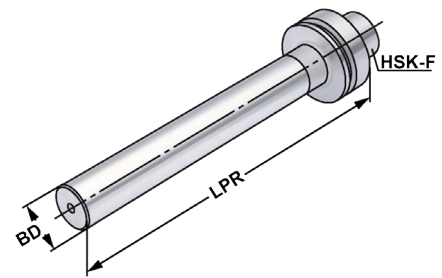

ISO 12164	Form F	$\leq 3\mu\text{m}$
--------------	-----------	---------------------

Bestell-Nr. Order no. Référence	HSK	LPR	BD	Toleranz Tolerance Tolérance	max. Rundlaufabweichung max. concentricity deviation Faux-rond max.
F63.18.40	HSK-F 63	346	40	0,003	0,003

Lieferumfang: Auslieferung mit Prüfprotokoll
Delivery: *Delivery with test certificate*
Livraison: Livraison avec rapport d essais

Holzkasten für Kontrolldorne

Wooden box for test arbors
Coffret en bois pour mandrins de contrôle



Verwendung:
Zur Aufbewahrung von Kontrolldornen.

Application:
For the storage of test arbors.

Application:
Pour la conservation de mandrins de contrôle.



Bestell-Nr. Order no. Référence	Abmessung Size Dimension	für Kegelgrößen for cones pour cônes
701.18	460 × 130 × 115	HSK 32 / 40 / 50 / 63 / 80 / 100

zum Spannen von HM und HSS Werkzeugschäften

Shrink chucks 4,5° for mounting of solid carbide and HSS-tool shanks

Mandrins de frettage 4,5° pour le serrage de queues d'outils carbures de type HM et HSS



Verwendung:
Zur Aufnahme von Werkzeugen mit Zylinderschaft.

Application:
For mounting straight-shank tools.

Application:
Pour le serrage d'outils avec queue cylindrique.

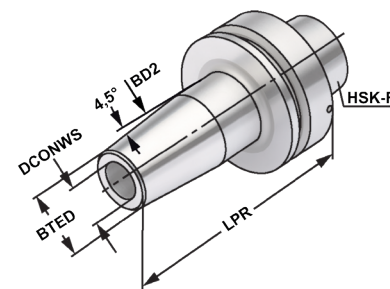

Bestell-Nr. Order no. Référence	HSK	DCONWS	TDCON	LPR	BTED	BD2	LSCN	LSCX	ADJRGA	THID
F63.70.03	HSK-F 63	3	h4	80	11	15	9	-	-	-
F63.70.04	HSK-F 63	4	h4	80	14	22	9	-	-	-
F63.70.05	HSK-F 63	5	h4	80	16	22	10	-	-	-
F63.70.06	HSK-F 63	6	h6	80	21	27	22	36	10	M5x0,8
F63.70.08	HSK-F 63	8	h6	80	21	27	26	36	10	M6x1
F63.70.10	HSK-F 63	10	h6	85	24	32	31	41	10	M8x1
F63.70.12	HSK-F 63	12	h6	90	24	32	36	46	10	M10x1
F63.70.14	HSK-F 63	14	h6	95	27	34	36	46	10	M10x1
F63.70.16	HSK-F 63	16	h6	95	27	34	39	49	10	M12x1
F63.70.18	HSK-F 63	18	h6	95	33	42	39	49	10	M12x1
F63.70.20	HSK-F 63	20	h6	100	33	42	41	51	10	M16x1
F63.70.25	HSK-F 63	25	h6	115	44	54	47	57	10	M16x1
F63.70.03.1	HSK-F 63	3	h4	120	11	15	9	-	-	-
F63.70.04.1	HSK-F 63	4	h4	120	16	22	9	-	-	-
F63.70.05.1	HSK-F 63	5	h4	120	16	22	10	-	-	-
F63.70.06.1	HSK-F 63	6	h6	120	21	27	22	36	10	M5x0,8
F63.70.08.1	HSK-F 63	8	h6	120	21	27	26	36	10	M6x1
F63.70.10.1	HSK-F 63	10	h6	120	24	32	31	41	10	M8x1
F63.70.12.1	HSK-F 63	12	h6	120	24	32	36	46	10	M10x1
F63.70.14.1	HSK-F 63	14	h6	120	27	34	36	46	10	M10x1
F63.70.16.1	HSK-F 63	16	h6	120	27	34	39	49	10	M12x1
F63.70.18.1	HSK-F 63	18	h6	120	33	42	39	49	10	M12x1
F63.70.20.1	HSK-F 63	20	h6	120	33	42	41	51	10	M16x1

LSCX = Einspannlänge, max.
LSCX = Clamping depth, max.
LSCX = Profondeur d'insertion, max.

ADJRGA = Verstellweg, max.
ADJRGA = Length adjustment range, max.
ADJRGA = Course de réglage, max.

Für Ø 3, 4 und 5 mm nur Hartmetallschäfte verwenden!

For Ø 3, 4 and 5 mm only solid carbide tool shanks must be used!

Pour Ø 3, 4 et 5 mm il faut seulement utiliser de queues d'outils carbures de type HM!

Hinweis: Aufnahme für Induktiv-, Kontakt- und Heißluftschumpfgeräte geeignet.
Schafttoleranz bei Ø 3, 4 und 5 mm = h₄, bei Ø 6 - Ø 32 mm = h₆

Note: Toolholders suitable for induction-, contact- and hot air shrink units.
Ø 3, 4, 5 with h₄-tolerance and Ø 6 - Ø 32 with h₆-tolerance

Observation: Porte-outils convenables pour machines à fretter par induction,
par contact, ou par air chaud.
Ø 3, 4, 5 avec h₄-tolerance et Ø 6 - Ø 32 avec h₆-tolerance



zum Spannen von HM und HSS Werkzeugschäften

Shrink chucks 4,5° for mounting of solid carbide and HSS-tool shanks

Mandrins de frettage 4,5° pour le serrage de queues d'outils carbures de type HM et HSS



Verwendung:
Zur Aufnahme von Werkzeugen mit Zylinderschaft.

Application:
For mounting straight-shank tools.

Application:
Pour le serrage d'outils avec queue cylindrique.

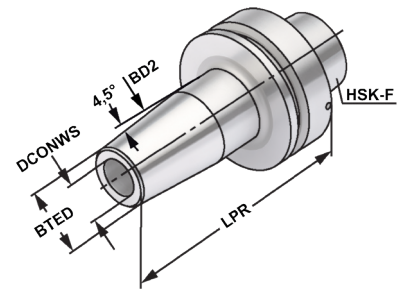

Bestell-Nr. Order no. Référence	HSK	DCONWS	TDCON	LPR	BTED	BD2	LSCN	LSCX	ADJRG	THID
F63.70.04.2	HSK-F 63	4	h4	160	16	22	9	-	-	-
F63.70.05.2	HSK-F 63	5	h4	160	16	22	10	-	-	-
F63.70.06.2	HSK-F 63	6	h6	160	21	27	22	36	10	M5x0,8
F63.70.08.2	HSK-F 63	8	h6	160	21	27	26	36	10	M6x1
F63.70.10.2	HSK-F 63	10	h6	160	24	32	31	41	10	M8x1
F63.70.12.2	HSK-F 63	12	h6	160	24	32	36	46	10	M10x1
F63.70.14.2	HSK-F 63	14	h6	160	27	34	36	46	10	M10x1
F63.70.16.2	HSK-F 63	16	h6	160	27	34	39	49	10	M12x1
F63.70.18.2	HSK-F 63	18	h6	160	33	42	39	49	10	M12x1
F63.70.20.2	HSK-F 63	20	h6	160	33	42	41	51	10	M16x1

LSCX = Einspannlänge, max.
LSCX = Clamping depth, max.
LSCX = Profondeur d'insertion, max.

ADJRG = Verstellweg, max.
ADJRG = Length adjustment range, max.
ADJRG = Course de réglage, max.

Für Ø 3, 4 und 5 mm nur Hartmetallschäfte verwenden!

For Ø 3, 4 and 5 mm only solid carbide tool shanks must be used!

Pour Ø 3, 4 et 5 mm il faut seulement utiliser de queues d'outils carbures de type HM!

Hinweis: Aufnahme für Induktiv-, Kontakt- und Heißluftschumpfergeräte geeignet. Schafttoleranz bei Ø 3, 4 und 5 mm = h₄, bei Ø 6 - Ø 32 mm = h₆

Note: Toolholders suitable for induction-, contact- and hot air shrink units. Ø 3, 4, 5 with h₄-tolerance and Ø 6 - Ø 32 with h₆-tolerance

Observation: Porte-outils convenables pour machines à fretter par induction, par contact, ou par air chaud. Ø 3, 4, 5 avec h₄-tolerance et Ø 6 - Ø 32 avec h₆-tolerance

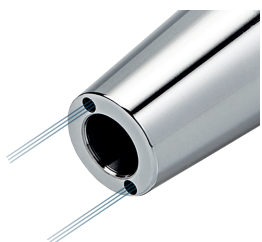

Nachträgliches Erodieren von 2 Kühlkanalbohrungen

Supplementary eroding of 2 cooling channels

Erodage complémentaire de 2 trous de canaux de refroidissement

Bestell-Nr.
Order no.
Référence

U.KKB



Hydraulic expansion chucks
Mandrins expansibles hydrauliques



Verwendung:
Zur Aufnahme von Werkzeugen mit Zylinderschaft nach DIN 1835 Form A+B+E und DIN 6535 Form HA+HB+HE (größer Ø 20 mm nur mit Reduzierung).

Application:
For mounting straight-shank tools acc. DIN 1835 form A+B+E and DIN 6535 form HA+HB+HE (larger).

Application:
Pour le serrage d'outils avec queue cylindrique suivant DIN 1835 forme A+B+E et DIN 6535 forme HA+HB+HE (à partir de dia. 20 mm seulement avec réduction).

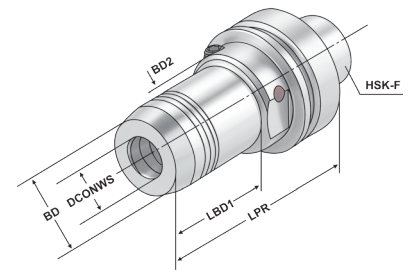

ISO 12164 Form F $\leq 3\mu\text{m}$ G7.5 25.000 min⁻¹



Bestell-Nr. Order no. Référence	HSK	DCONWS	LPR	BD	BD2	LSCX	ADJRGA	LBD1	DRVS	THID
F63.H06	HSK-F 63	6	100	26	50	37	10	45	5	M6x1
F63.H08	HSK-F 63	8	100	28	50	37	10	44	5	M6x1
F63.H10	HSK-F 63	10	100	30	50	42	10	46	5	M8x1
F63.H12	HSK-F 63	12	100	32	50	47	10	45,5	5	M8x1
F63.H14	HSK-F 63	14	100	34	50	47	10	44	5	M10x1
F63.H16	HSK-F 63	16	100	38	50	52	10	44	5	M12x1
F63.H18	HSK-F 63	18	100	40	50	52	10	42	5	M12x1
F63.H20	HSK-F 63	20	100	42	50	52	10	42	5	M12x1
F63.H25	HSK-F 63	25	120	50	50	58	10	26	6	M12x1
F63.H32	HSK-F 63	32	125	60	50	62	10	26	6	M12x1

LSCX = Einspannlänge, max.
LSCX = Clamping depth, max.
LSCX = Profondeur d'insertion, max.

ADJRGA = Verstellweg, max.
ADJRGA = Length adjustment range, max.
ADJRGA = Course de réglage, max.

Lieferumfang: Ohne Spannschlüssel
Delivery: Without wrench
Livraison: Sans clé de serrage

Gewuchtete Ausführung



Balanced type
Type équilibré

Bestell-Nr. Order no. Référence	Abmessung Size Dimension
---------------------------------------	--------------------------------

Wuchten auf G 2,5 von vorgewuchteten Kemmler-Werkzeugen

Balancing at G 2,5 of pre-balanced Kemmler-tools
Équilibrage sur G 2,5 d'outils Kemmler pré-équilibrés

W25 Ohne Wuchtprotokoll
Without balancing report
Sans protocole d'équilibrage

W25.2 Mit Wuchtprotokoll
With balancing report
Avec protocole d'équilibrage

Wuchten von nicht vorgewuchteten Werkzeugen
Balancing of unbalanced tools
Équilibrage d'outils non-équilibrés

W25.1 Ohne Wuchtprotokoll
Without balancing report
Sans protocole d'équilibrage



Reparatur und Wartung für Hydro-Dehnspannfutter

Die Hydro-Dehnspanntechnik ist eine weltweit verbreitete, bewährte und zuverlässige Methode zur Aufnahme von Werkzeugen. Dank ihrer konstruktiven Vorteile ist sie unempfindlich, wartungsarm und langlebig. Dennoch kommt es durch thermische und mechanische Belastung im Werkstattgebrauch im Laufe der Zeit zu Spannkraftverlusten. Die Folge sind schlechtere Werkzeugstandzeiten und Qualitätseinbußen bei der Bearbeitung bis hin zum teuren Werkzeugbruch.

Wir warten und reparieren Ihre Hydro-Dehnspannfutter - egal ob von uns oder ein Fremdfabrikat - kostengünstig hier bei uns in Süd-Deutschland.

Hier prüfen wir die Ursachen für den Spannkraftverlust und reparieren innerhalb von zwei Wochen zu einem günstigen Festpreis. Wir erneuern dabei alle Verschleißteile, befüllen das Hydrauliksystem neu und justieren das Hydrauliksystem auf den korrekten Spanndruck. Abschließend erfolgt eine Endprüfung.

Kontaktieren Sie unseren Kundenservice für weitere Informationen und Preise.

Maintenance and repair of hydraulic chucks

Clamping of tools with hydraulic chucks is a widespread, well-established and reliable method. It is a resistant, easy-to-operate and durable way of clamping due to its advantageous construction design. Nevertheless in the course of time under the influence of thermal and mechanical outputs at factories loss of clamping force is observed. As a result the life of the tool shortens and its quality during the working process reduces. Therefore it leads to a costly damage of the tool.

We maintain and repair your hydraulic chucks - both those manufactured at our place and those produced somewhere else - for a reasonable price here at our office in the south of Germany.

We check possible causes of the clamping force reduction and repair it within two weeks at a fixed low price. At the same time we renew all the fast wearing parts, fill the hydraulic system anew and adjust its clamping force. Afterwards the final inspection stage takes place.

You are welcome to contact our customer service for further information and prices.

La réparation et la maintenance des mandrins hydrauliques

L'accueil des outils à l'aide d'un mandrin hydraulique est une technique éprouvée, répandue à l'échelle mondiale et de confiance. Grâce à sa construction avantageuse elle est robuste, facile à entretenir et durable. Pourtant à cause de la charge thermique et mécanique imposés sur les mandrins lors du travail la tension du ressort diminue au fil du temps. Par conséquent la résistance des outils coupants se détériore et la qualité lors d'usinage se réduit. En retour cela conduit à la rupture coûteuse d'outil.

On entretient et répare vos mandrins hydrauliques - peu importe l'issue de notre production ou d'ailleurs - bon marché et ici chez nous au sud de l'Allemagne.

Tout d'abord nos spécialistes cherchent la cause de la perte de la tension du ressort, ensuite ils effectuent la réparation sous 2 semaines pour le prix fixe et favorable. En outre ils renouvellent toutes les pièces d'usure, remplissent le système hydraulique à nouveau et ajustent la tension correcte. À la fin l'inspection finale se déroule.

Contactez notre centre de service client pour obtenir l'information supplémentaire ainsi que l'information actuelle sur le prix.



**WERKZEUGAUFNAHMEN
MIT POLYGONALSCHAFT
ISO 26623-1**

**TOOLHOLDERS
POLYGONAL SHANK
ISO 26623-1**

**PORTE-OUTILS
À QUEUE POLYGONALE
ISO 26623-1**