

ACTIE

BROGCHURE

YOUNG
CUTTINGTOOLS



ALLES OP HET GEBIED VAN VERSPANING

Young cuttingtools is de grootste leverancier als het gaat om gereedschappen voor verspaning. U vraagt bij ons niet mis op het gebied van metaalbewerking en verspaning. Door middel van het geven van gerichte adviezen over toepassing en gebruik van de juiste gereedschappen zijn wij uw betrouwbare partner voor efficiënter produceren in de metaalbewerkingbranche.



SNELLE LEVERING EN TECHNISCHE ONDERSTEUNING

Wij zijn gevestigd in het Brabantse Eersel waar een groot deel van het assortiment op voorraad ligt. Een efficiënte logistiek zorgt voor snelle levering van de diverse producten. Vanuit ondersteuningspunten in Friesland, Brabant en Overijssel wordt de gehele Nederlandse markt persoonlijk bediend. Young cuttingtools levert rechtstreeks van de fabrikant naar de klant waardoor de kwaliteitsmerken scherp worden aangeboden.

JARENLANGE ERVARING

Wij hebben jarenlange ervaring in de metaalbewerkingbranche en verspaning. Onze toegevoegde waarde is probleemoplossend en technisch advies over de toepassing en het gebruik van verspanende gereedschappen, versterkt met technische ondersteuning en service.

YOUNG
CUTTINGTOOLS

GEÏNTERESSEERD?

Neem gerust contact met ons op voor een vrijblijvend advies en informatie over wat Young cuttingtools voor uw bedrijf kan betekenen.

ONZE MERKEN

Wij zijn aanbieder van een totaalpakket aan verspanende gereedschappen en exclusief dealer van de topmerken YG-1, Avantec, Korloy en Ecoroll in de Nederlandse markt. Het Koreaanse YG-1 behoort tot de grootste producenten ter wereld van boren, tappen en frezen. Dus zoekt u een specifieke hoekfrees, vlakfrees of miniatuurfrees? Een titaniumfrees? Ook voor de juiste koelkanaalboor of volboor is Young cuttingtools het beste adres.

Het aanbod van Young cuttingtools wordt verder aangevuld met dealerschappen van Gerardi (opspangereedschappen), AMF (opspangereedschappen), Mitutoyo (meetgereedschappen), Nine9 (afbraam-, grafeer- en centergereedschappen) en Wemag totaalaanbieder.

WAAROM YOUNG CUTTINGTOOLS?

- ✓ Jarenlange ervaring
- ✓ Gericht advies
- ✓ Snelle levering
- ✓ Totaalpakket in verspaning



NIEUWS

Het nieuw opgerichte YG-1 Technology Center is onderdeel van YG-1 Co. LTD en is gespecialiseerd in de ontwikkeling en productie van precisiegereedschappen voor het bewerken van vrijwel alle materialen. Wij leveren aan bekende klanten in de automobiellindustrie, lucht- en ruimtevaart, machine- en installatietechniek en de medische sector in meer dan 75 landen wereldwijd. Sinds mei 2020 zijn we gevestigd in ons nieuw gebouwde technologiecentrum in Oberkochen.



Expertise
in efficiënter
produceren

BORENSET



€ 99,-

- Kruisaanslijping zelfcentrerend
- Geschikt voor rvs, gelegerde en ongelegerde staalsoorten
- Hoge standtijden

Premium HSS-E geslepen boren DIN338 met TIN-tip coating

Inhoud: 25 stuks 1-13 (0.5mm oplopend)

Bestelnummer: DLGP195SET2

BOOR / TAP SET



€ 82,50

- HSS Stoom ontladen
- Geschikt voor gelegerde en ongelegerde staalsoorten

Universeel boren/tappenset:

Inhoud: HSS-E Combo tappen M3, M4, M5, M6, M8, M10, M12

Inhoud: HSS-E Goldpoint boren Ø2.5, 3.3, 4.2, 5.0, 6.8, 8.5, 10.2

Bestelnummer doorlopend: TC814SET-DLGP

Bestelnummer blind: TC804SET-DLGP

STIFFREZEN SET



€ 119,-

- Geschikt voor gelegerde en ongelegerde staalsoorten
- Schacht 6mm
- Hoge standtijden

Inhoud: Assortiment 10 stuks (6 t/m 12mm)

Bestelnummer: SETRB10

VERZINKBOREN SET



€ 99,-

- Geschikt voor gelegerde en ongelegerde staalsoorten
- Schacht 6mm
- Hoge standtijden

YG-1 HSS-Co8 Verzinkborensset 90° met TiAlN coating (8% Cobalt)

Inhoud: 6.3 | 8.3 | 10.4 | 12.4 | 16.5 | 20.5 | 25

• Bestelnummer: C1339S70

• Geschikt voor rvs, gelegerde-, ongelegerde staalsoorten

• Hoge standtijden

HSS-E TAPPENSET UNI



€ 65,-

- YG-1 speciale gepatenteerde geometrie
- Uitstekende prestaties in meerdere materialen (staal, rvs)
- Voor perfect gevormde schroefdraad
- Hoge standtijden

Inhoud: M3 | M4 | M5 | M6 | M8 | M10 | M12

Bestelnummer doorlopend: TC814SET7

Bestelnummer blind: TC804SET7

HSS-E TAPPENSET RVS



€ 75,-

- YG-1 RVS tappenserie
- YG-1 speciale gepatenteerde geometrie
- Uitstekende prestaties in RVS soorten
- Voor perfect gevormde schroefdraad
- Hoge standtijden

Inhoud: M3 | M4 | M5 | M6 | M8 | M10 | M12

Bestelnummer doorlopend: TB623SET7

Bestelnummer blind: TB914SET7

HSS-PM PREMIUM-TAPPEN

- Premium doorlopende en blinde tappen voor CNC-machines
- Hoge en betrouwbare prestaties in verschillende moeilijkere materialen
- Nieuwe Prime X-Coating
- Speciaal slijpproces biedt een unieke geometrie dat zorgt voor verbeterde spaanafvoer



HSS-PM PRIME TAPPENSET



€ 125,-

Inhoud: M3 | M4 | M5 | M6 | M8 | M10 | M12
Blinde gaten
Artikelnummer: TRE30GSSET7

HSS-PM PRIME TAPPENSET



€ 125,-

Inhoud: M3 | M4 | M5 | M6 | M8 | M10 | M12
Doorlopende gaten
Artikelnummer: TRJ15GSSET7

SPANTANGHOUDERS ER

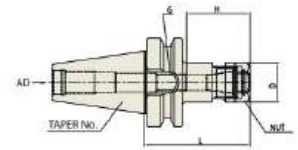
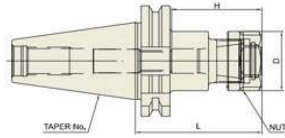

DIN 69871 -SK	Taper Accuracy AT3	G Value 6.3	RPM 15.000	Coolant System AD
-------------------------	------------------------------	-----------------------	----------------------	-----------------------------

JIS B6339 -BT	Taper Accuracy AT3	G Value 6.3	RPM 15.000	Coolant System AD
-------------------------	------------------------------	-----------------------	----------------------	-----------------------------

Artikelnummer	Model	Actieprijs
P2776417	SK40AD - ER16 - 70	€ 30,00
P2527018	SK40AD - ER16 - 100	€ 35,00
P2776418	SK40AD - ER20 - 70	€ 30,00
P2527019	SK40AD - ER20 - 100	€ 35,00
P2776419	SK40AD - ER25 - 70	€ 30,00
P2776429	SK40AD - ER25 - 100	€ 35,00
P2776420	SK40AD - ER32 - 70	€ 30,00
P2776430	SK40AD - ER32 - 100	€ 35,00
P2527011	SK40AD - ER40 - 80	€ 35,00

Artikelnummer	Model	Actieprijs
P2772101	BT40AD - ER16 - 75	€ 30,00
P2772118	BT40AD - ER16 - 100	€ 35,00
P2772102	BT40AD - ER20 - 75	€ 30,00
P2772120	BT40AD - ER20 - 100	€ 35,00
P2772103	BT40AD - ER25 - 75	€ 30,00
P2772122	BT40AD - ER25 - 100	€ 35,00
P2772104	BT40AD - ER32 - 60	€ 30,00
P2772125	BT40AD - ER32 - 100	€ 35,00
P2772127	BT40AD - ER40 - 80	€ 35,00



ER 8 P2506301		
STANDAARD SET	208000	€ 89,-
Ø 1.0 - 5.0mm		
9pcs		
CASSETTE ZWT 8	108110	

ER 11 P2506302		
STANDAARD SET	211000	€ 115,-
Ø 1.0 - 7.0mm		
13pcs		
CASSETTE ZWT 11	011110	

ER 16 P2506303		
STANDAARD SET	216000	€ 89,-
Ø 1.0 - 10.0mm		
10pcs		
CASSETTE ZWT 16	016110	

ER 20 P2506304		
STANDAARD SET	220000	€ 105,-
Ø 2.0 - 13.0mm		
12pcs		
CASSETTE ZWT 20	020110	

ER 25 P2506305		
STANDAARD SET	225000	€ 133,-
Ø 2.0 - 16.0mm		
15pcs		
CASSETTE ZWT 25	025110	

ER 32 P2506306		
STANDAARD SET	232000	€ 166,-
Ø 3.0 - 20.0mm		
18pcs		
CASSETTE ZWT 32	032110	

ER 40 P2506307		
STANDAARD SET	240000	€ 230,-
Ø 4.0 - 26.0mm		
23pcs		
CASSETTE ZWT 40	040110	

ER 50 P2506308		
STANDAARD SET	250000	€ 280,-
Ø 12.0 - 34.0mm		
12pcs		
CASSETTE ZWT 50	050110	

ER SPANTANGSLEUTELS

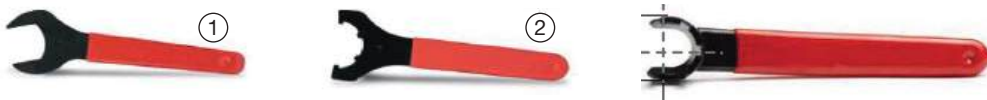

Artikelnummer	Model	Actieprijs
P2772601	SLEUTEL ER11 (fig.1)	€ 7,50
P2772602	SLEUTEL ER16 (fig.1)	€ 7,50
P2772603	SLEUTEL ER20 (fig.1)	€ 7,50
P2772604	SLEUTEL ER25 (fig.2)	€ 7,50
P2772605	SLEUTEL ER32 (fig.2)	€ 7,50
P2772606	SLEUTEL ER40 (fig.2)	€ 7,50

Artikelnummer	Model	Actieprijs
P2772612	SLEUTEL ER50 (fig.2)	€ 8,50
P2772608	SLEUTEL MINI ER8	€ 11,00
P2772609	SLEUTEL MINI ER11	€ 11,00
P2772610	SLEUTEL MINI ER16	€ 11,00
P2772611	SLEUTEL MINI ER20	€ 13,00
P2772607	SLEUTEL MINI ER25	€ 13,00

OPSTEEKHOUDERS



DIN 69871 -SK	Taper Accuracy AT3	G Value 6.3	RPM 15.000	Coolant System AD
---------------	--------------------	-------------	------------	-------------------

Artikelnummer	Model	Actieprijs
P2778904	SK40AD - SMA16-60	€ 35,00
P2778905	SK40AD - SMA22-60	€ 35,00
P2778906	SK40AD - SMA27-60	€ 37,00
P2778907	SK40AD - SMA32-60	€ 39,00
P2778908	SK40AD - SMA40-60	€ 49,00



JIS B6339 -BT	Taper Accuracy AT3	G Value 6.3	RPM 15.000	Coolant System AD
---------------	--------------------	-------------	------------	-------------------

Artikelnummer	Model	Actieprijs
P2778804	BT40AD - SMA16-60	€ 35,00
P2778805	BT40AD - SMA22-60	€ 35,00
P2778806	BT40AD - SMA27-60	€ 37,00
P2778807	BT40AD - SMA32-60	€ 39,00
P2778808	BT40AD - SMA40-60	€ 49,00

WELDONHOUDERS

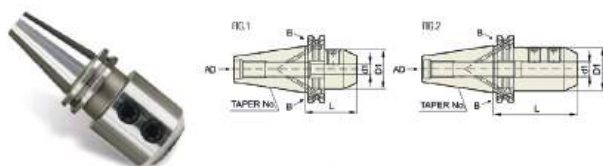

DIN 69871 -SK	Taper Accuracy AT3	G Value 6.3	RPM 15.000	Coolant System AD
---------------	--------------------	-------------	------------	-------------------

Artikelnummer	Model	Actieprijs
P2521009	SK40AD - EMH6-50	€ 25,00
P2521010	SK40AD - EMH8-50	€ 25,00
P2521011	SK40AD - EMH10-50	€ 25,00
P2521012	SK40AD - EMH12-50	€ 25,00
P2521013	SK40AD - EMH16-63	€ 25,00
P2521014	SK40AD - EMH20-63	€ 25,00
P2521015	SK40AD - EMH25-100	€ 31,00
P2521016	SK40AD - EMH12-100	€ 33,00

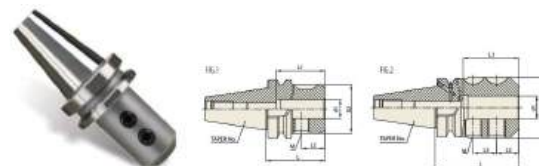

JIS B6339 -BT	Taper Accuracy AT3	G Value 6.3	RPM 15.000	Coolant System AD
---------------	--------------------	-------------	------------	-------------------

Artikelnummer	Model	Actieprijs
P2773061	BT40AD - EMH6-50	€ 25,00
P2773062	BT40AD - EMH8-50	€ 25,00
P2773063	BT40AD - EMH10-63	€ 25,00
P2773064	BT40AD - EMH12-63	€ 25,00
P2773066	BT40AD - EMH16-63	€ 25,00
P2773068	BT40AD - EMH20-63	€ 25,00
P2773069	BT40AD - EMH25-90	€ 31,00
P2773070	BT40AD - EMH32-100	€ 33,00

YG-1 TAPER MILLING CUTTER

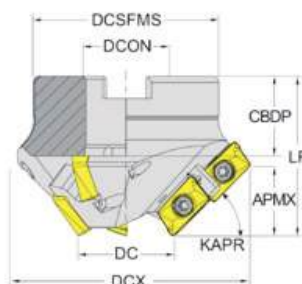

Artikelnummer	Kwaliteit	APKT	omschrijving	RE (mm)	Fz (mm/tand)	BS (mm)
12000001	YG602	APKT General	APKT 160408 PDTR (standaard)	0.8	0.15 ~ 0.30	1.32
12000617	YG613	-ST Stainless Steel Super Alloy	APKT 160408 - ST (RVS)	0.8	0.08 ~ 0.25	1.32

Artikelnr.	KAPR	APMX	DC	DCX	ZEFP	CICT	LF	L2	DCON	CBDP	DCSFMS	PRIJS
17000630	15°	8,0	35	93	2.7	7	17	57	27	25	58	€279,00
17000631	45°	21,5	35	77	3.7	11	16	57	27	25	58	
17000632	60°	26,5	35	65	4.7	13	18	57	22	22	48	
17000633	75°	29,5	35	50	5.5	13	21	57	22	22	42	

HM-WISSELPLATEN FREES



PRODUCTINFORMATIE



Voor meerdere toepassingen zijn wisselplaten beschikbaar, voor algemeen staal, voorgehard staal, hooggelegeerd staal, gehard staal, RVS en grafiet.



STRAIGHT NECK	STRAIGHT NECK	TAPER NECK	STRAIGHT NECK	STRAIGHT NECK
Carbide	Steel	Steel	Carbide	Steel



AITIN	XC-Coating	Z-Coating	AITIN
GENERAL PURPOSE	PRE-HARDENED STEELS	HIGH HARDENED STEELS	STAINLESS STEELS

Y-Coating	Diamond	AITIN	XC-Coating	Z-Coating	Y-Coating	Diamond
GENERAL PURPOSE	GRAPHITE	GENERAL PURPOSE STAINLESS STEELS	PRE-HARDENED STEELS	HIGH HARDENED STEELS	GENERAL PURPOSE	GRAPHITE

YG-1 VLAKFREES PNMU12

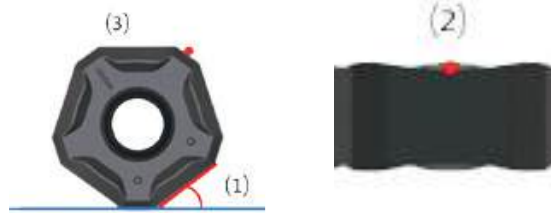

PRODUCTINFORMATIE



De PNMU heeft 10 snijkanten met een inloophoek van 36 graden, wat zorgt voor een hogere productiviteit en stabiele snijprestaties!

1. INLOOPHOEK 36°

- Verhoogt de voedingssnelheid
- Kleinere gemiddelde spaandikte

2. GEBOGEN SNIJKANT MET WIPER

- Verbeter de snijkraft en de oppervlakterutheid

3. SNIJKANTEN PER WISSELPLAAT

- Kostenbesparend voor de klant



SENSATIE IN DE MACHINE

YG-1 TPKT HOEFREES 90°

- Geoptimaliseerde geometrie
- Minimale braamvorming



PRODUCTINFORMATIE



POSITIEVE WISSELPLAAT

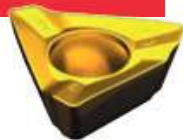

90° Hoekfrees

Grotere kern zorgt voor betere stijfheid

Optimale plaatsing van de wisselplaten zorgt voor een hoge productiviteit



NIEUW

NIEUWE CVD-DRAAIWISSELPLAAT YG2025 VOOR HOGE SNIJSNELHEID IN RVS SOORTEN



- Vernieuwd hardmetaalkwaliteit en nieuwe coating!
- Uitzonderlijke prestaties in RVS bij hoge snijsnelheid
- Zeer geschikt voor massaproductie vanwege stabiele en voorspelbare standtijd
- Meerdere verschillende spaanbrekers
- Beste keuze voor zowel continue als onderbroken sneden
- Minimaliseren van snijkantsopbouw door nieuwe nabehandeling van de wisselplaat

NIEUW

NIEUWE CVD-DRAAIWISSELPLAAT YG3115 VOOR HOGE SNIJSNELHEID IN STAAL SOORTEN



- Uitzonderlijke prestaties in staal bij hoge snijsnelheid
- Uitstekend oppervlak
- Zeer geschikt voor massaproductie vanwege stabiele en voorspelbare standtijd
- Beste keuze voor zowel continue als onderbroken sneden
- Meerdere verschillende spaanbrekers
- Minimaliseren van snijkantsopbouw door nieuwe nabehandeling van de wisselplaat

AMF KRACHTSPANNERS



Art. Nummer	Grootte	Max. belasting statisch (kN)	M	T-gleuf	H	E	L	Gewicht (g)	Actieprijs (p.st.)
562184	22	22	M10	12	5-38	15-50	65	700	€ 139,00
556406	22	22	M12	14	5-38	15-50	65	700	€ 139,00
556186	30	30	M12	14	6-68	13-110	135	2013	€ 219,50
565187	30	30	M16	18	6-68	16-114	135	2045	€ 219,50
556189	32	32	M12	14	6-50	12-82	95	1462	€ 194,00
556190	40	40	M16	18	6-50	15-95	110	2262	€ 224,00
556188	43	43	M16	18	5-80	16-134	155	3158	€ 236,00
563656	44	44	M18	20	7-88	19-165	175	5880	€ 245,00
554198	49	49	M20	22	7-88	19-165	175	5928	€ 314,00
564654	49	49	M24	28	8-102	63-180	203	8950	€ 383,00

VOORDELEN

Traploos instelbare krachtspanners van gelegeerd gehard staal. gesmeed, zwart gegalvaniseerd ontwerp. Compleet met montageset 7600BFS. (T-gleufmoer met binnenzeskantbout).

- Spankracht 22kN -49kN
- Traploos in hoogte verstelbaar
- Snel en eenvoudig spannen
- T-gleuven 12-28mm
- Lage totale hoogte (te verhogen met AMF tussenelement Nr. 7600Z)

AMF SPANSYSTEMEN

- Nulpuntspansystemen "Zero-Point"
- Hydraulische spantechniek
- Magneetspantechniek
- Vacuümspantechniek
- Enkel- een meervoudige spansystemen
- Modulaire opstansystemen
- Blokspansystemen
- Snelspanners
- Mechanische panelementen



KING DRILL ACTIE

DE PERFECTE VOLBOOR VOORZIEN VAN WISSELPLATEN MET 4 SNIJKANTEN

Geoptimaliseerd ontwerp wisselplaatboor voor maximale boorefficiëntie.



SET IS COMPLEET MET:

- 1 boor
- 10 centrumwisselplaten
- 10 buitenwisselplaten

Ø Boor (mm)	Grootte wisselplaat	Aantal wisselplaten		Lengte van de boor			
		Buiten 10x	Centrum 10x	2xD	3xD	4xD	5xD
12.0 – 13.5	4	SPMT040204-PD	XOMT040204-PD	€ 314,00	€ 314,00	€ 332,00	€ 422,50
14.0 – 16.0	5	SPMT050204-PD	XOMT050204-PD	€ 350,00	€ 350,00	€ 371,00	€ 473,00
16.5 – 19.5	6	SPMT060205-PD	XOMT060204-PD	€ 351,50	€ 351,50	€ 372,00	€ 474,00
20.0 – 23.5	7	SPMT07T208-PD	XOMT07T205-PD	€ 366,00	€ 366,00	€ 387,50	€ 497,00
24.0 – 29.5	9	SPMT090308-PD	XOMT090305-PD	€ 393,00	€ 393,00	€ 417,00	€ 535,00
30.0 – 35.5	11	SPMT11T308-PD	XOMT11T306-PD	€ 443,50	€ 443,50	€ 470,00	€ 604,00
36.0 – 42,5	13	SPMT130410-PD	XOMT130406-PD	€ 466,50	€ 466,50	€ 545,50	€ 636,00
43,0 – 50.5	15	SPMT15M510-PD	XOMT15M508-PD	€ 512,50	€ 512,50	€ 593,00	€ 704,50
51.0 - 60.5	18	SPMT180510-PD	XOMT180508-PD	€ 575,00	€ 575,00	€ 610,00	€ 787,50

Ø61-100 op aanvraag

** Coating van de wisselplaten zijn naar keuze.

*** Prijzen voor aluminium wisselplaat op aanvraag.



HIGHLY PRECISE AND EFFICIENT TOP SOLID INDEXABLE DRILL

TPDB PLUS DRILL



Special surface treatment
Improved durability of a holder

Advanced chip control
due to a chip breaker

High helix angle

High productivity
- Stable chip evacuation realizes stable machinability
- Decreases cycle time by applying improved cutting conditions

Improve in machining quality
- Good surface finish and regular size in the hole

Auto-centering system

Cutting edge with low cutting resistance
Low cutting load and excellent chip control

Screw on clamping system

NC SPOT DRILL

Één gereedschap voor meerdere toepassingen

- Graveren, centreren, afkanten en v-groeven
- Hoge standtijd
- Elke wisselplaat heeft 2 of 4 snijkanten
- 45° / 60° / 82° / 90° / 100° / 120° / 142° Hoek voor verschillende toepassingen

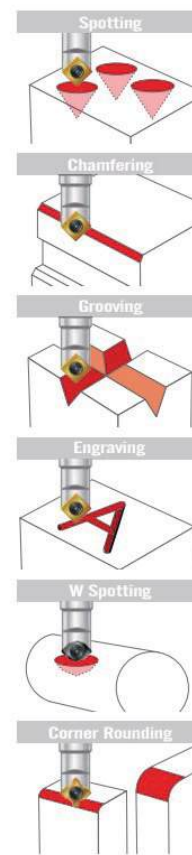

ACTIE
€ 209,-



Artikelnummer: 604204-4401

DRAAIMOMENT SCHROEVENDRAAIERSET TORX, 25MM + 50MM BITS SLOKY

ACTIE
€ 159,-

Artikelnummer	Inhoud					
	Handgreep	Adapter				Bit
		Grootte	Nm	Kgfm	In-lb	25mm + 50mm
0-TPK01-TGTX-12K	0-TPK-H02-R	TX06	0.6	6.1	5.3	ACTIE € 159,-
		TX07	0.9	9.2	8.0	
		TX08	1.2	12.0	10.6	
	0-TPK-H01-R	TX09	1.4	14.0	12.4	
		TX10	2.0	20.4	17.7	
		TX15	3.0	30.6	26.6	



SLOKY ELEKTRONISCHE SCHROEVENDRAAIER

Quicke

- Voor zowel handmatige als elektrische modus.
- Elektrische schroefaansluiting met beveiligingsfunctie tegen schade.
- 1/4 inch zeskantige dop
- Ingebouwde overlaadbeveiliging voor de accu.
- Rotatiemodus: met de klok mee en tegen de klok in.
- LED-lampje en micro-USB-oplaadpoort

SPECIFICATIES

Opname: **1/4- Inch-zeskant (6,35mm)**

Moment in elektrische modes: **tot 0,6 Nm**

Opladmethode: **Micro USB 5V 1A**

Moment in handmatige modus: **tot 10 Nm**

Batterij: **1,5 Ah**

Afmeting (l x b x h): **150 x 40 x 40**

Accu-type: **Lithium-Ionen**

Gewicht: **186 g**

Batterijspanning: **3,6 volt**

Tourental (max.): **300 U/min**

Omgevingstemperatuur voor opladen: **0 - 40 graden**

INHOUD

3,6 v Accuschroevendraaier

1 x Micro USB-oplaadkabel

1 x Verpakkingsdoos



Artikelnummer: 0-TKP-ETS-TE-01

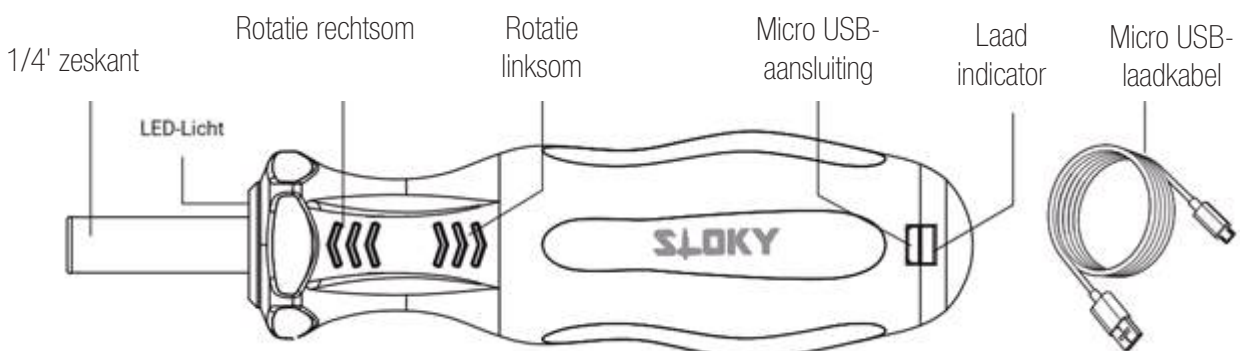

GERARDI MODULAIRE PRECISIE MACHINEKLEM

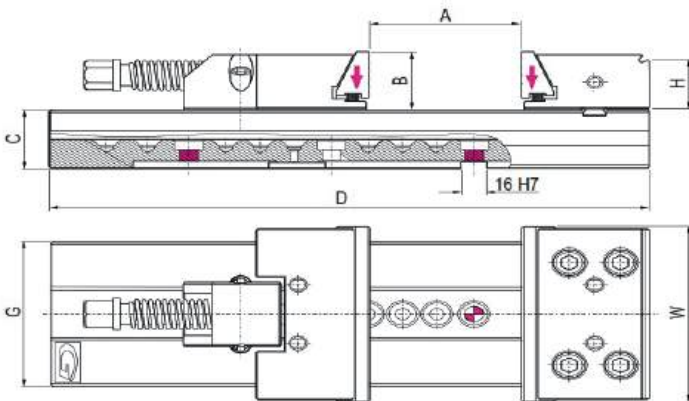

Afmetingen	Type 3 30 kN	Normaal	Actieprijs
A max.	300	€ 957,-	<div style="background-color: red; color: white; padding: 10px; border-radius: 50%; display: inline-block;"> ACTIE € 698,- </div>
W	150		
B	50		
C	50		
D	520		
G	125		
kg	29		
Artikel	3.03.3000		

* PRIJS IS INCLUSIEF:

- 1 stuk werkstukaanslag Art. 370
- 4 stuks opspanblokken Art. 298
- 1 set positioneerblokkjes Art. 297
- 1 spansleutel Art. 375
- 1 zeskant stelsleutel Art. 376

COMPACT GRIP VISES

Self centering vises with reversible jaws - Ideal for 5 axis machining centres

ART. 650

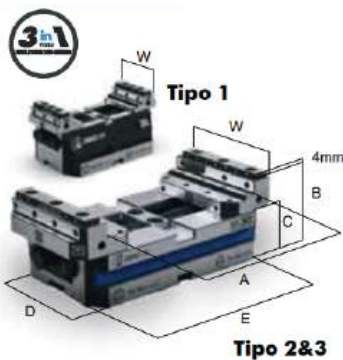

TYPE	jaw width	Max opening	Vise height	Base height	Base width	Base width	Kg	Code	LIST PRICE	ACTIE PRIJS
	W	A	B	C	D	E				
1 12kN	50	54	65	45	79,9	80	1,9	7.65.01080	€ 777,00	€ 649,00
		94				120	2,7	7.65.01120	€ 897,00	€ 749,00
		134				160	3,4	7.65.01160	€ 1015,00	€ 849,00
2 22kN	88	96	65	38	89,9	120	3,6	7.65.02120	€ 955,00	€ 749,00
		136				160	4,4	7.65.02160	€ 1075,00	€ 849,00
		176				200	5,2	7.65.02200	€ 1194,00	€ 949,00
		216				240	5,8	7.65.02240	€ 1314,00	€ 1049,00
3 32kN	123	133	89	57	124,9	160	9,1	7.65.03160	€ 1552,00	€ 1249,00
		183				210	10,9	7.65.03210	€ 1790,00	€ 1349,00
		233				260	12,8	7.65.03260	€ 2029,00	€ 1449,00
		283				310	14,8	7.65.03310	€ 2387,00	€ 1749,00
		333				360	17	7.65.03360	€ 2625,00	€ 1949,00



Standard equipment: 1 Box wrench, 1 calibrated centering, 2 position key-nuts and self-centering key-nuts, 2 top jaw inserts Art. 650T G11 pitch 11 mm

+ Magnetic Workshop Art. 370EM

DRIVEN TOOLS HOLDERS



BMT

Bolt Mounted Turret

COMPATIBLE WITH

DOOSAN / HARDINGE / SAMSUNG / HWACHEON / HYUNDAI WIA / VICTOR / HAAS

BMT 65 ALSO COMPATIBLE WITH HAAS LATHES!



Axial



BMT	Cod.	ER	H Max	Nm Rpm	LIST PRICE €	SPECIAL PRICE €
45	99.DS.A03	25	57,2	35 8000	1.033	839
45	99.DS.A04	25	57,2	35 8000	1.179	929
55	99.DS.A01	25	57,2	40 8000	1.363	899
55	99.DS.A02	25	57,2	40 8000	1.243	979
65	99.DS.A41	32	72,5	70 6000	1.274	1.049
65	99.DS.A42	32	72,5	70 6000	1.465	1.179
75	99.DS.A34	40	90,2	100 6000	1.497	1.249
75	99.DS.A35	40	90,2	100 6000	1.720	1.399



Radial



BMT	Cod.	ER	H	Nm Rpm	LIST PRICE €	SPECIAL PRICE €
45	99.DS.A07C	25	65	35 8000	1.822	1.499
45	99.DS.A08C	25	65	35 8000	2.190	1.799
55	99.DS.A11C	25	70	40 8000	2.038	1.599
55	99.DS.A12C	25	70	40 8000	2.408	1.899
65	99.DS.A51C	32	72	70 6000	2.140	1.699
65	99.DS.A52C	32	72	70 6000	2.534	1.999
75	99.DS.A38C	40	60	100 6000	3.311	2.649
75	99.DS.A39C	40	60	100 6000	3.973	3.099



Adjustable



BMT	Cod.	ER	H	Nm Rpm	LIST PRICE €	SPECIAL PRICE €
45	99.DS.A16	20	65	15 8000	4.698	3.899
45	99.DS.A17	20	65	15 8000	6.111	4.699
55	99.DS.A23	20	65	15 8000	4.698	3.899
55	99.DS.A66	20	65	15 8000	6.111	4.699
65	99.DS.A64	25	75	25 6000	5.221	4.299
65	99.DS.A65	25	75	25 6000	6.748	5.199
75	99.DS.A47	25	75	25 6000	5.221	4.299
75	99.DS.A48	25	75	25 6000	6.748	5.199

Both direction of rotation to machine spindle available

BMT ATTACHMENT WITH STANDARD TENON

High Performance version with bigger tenon available on request

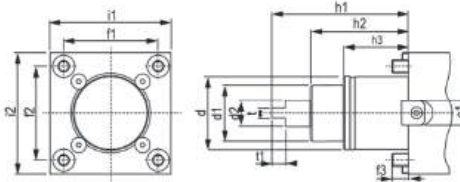

BMT	c1	d	d1	d2	f1	f2	f3	h1	h2	h3	i1	i2	t	i2	h4	N	ØM
45	15	Ø45	35	14	58	58	10	84	60	40	75	75	6	8,5	-	-	-
55	15	Ø55	40	16	64	64	14	104	75	30	85	85	8	8,5	9,5	8	29
65	18	Ø65	45	18	70	73	15	112	83	32	94	94	10	14	15	10	29
75	25	Ø75	55	23	90	90	15	110	80	43	112	112	14	15	-	-	-
85	25	Ø85	65	33,5	100	100	18	140	100	43	125	125	16	20	-	-	-

SPECIAL OFFER ON THE NEW RANGE OF DRIVEN TOOLS

Mazak QTN3

QUICK TURN NEXUS QTN
300 / 350 / 400 / 450 -
SQT 28 / 30 - 300



Off-set Axis

Cod.	ER	H	Nm Rpm	LIST PRICE €	SPECIAL PRICE €
99.MZ.A71	40	145	100 4000	3.320	3.100
99.MZ.A72	40	145	100 4000	3.631	3.300

Mazak QTN2
12 Positions

QUICK TURN NEXUS
QTN 200 / 250
SUPER QUADREX TURN
SQT 15/18 - 200 / 250

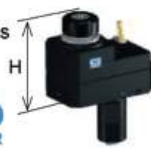

Cod.	ER	H	Nm Rpm	LIST PRICE €	SPECIAL PRICE €
99.MZ.A58	32	120	80 6000	2.491	1.549
99.MZ.A59	32	120	80 6000	3.010	2.100

Mazak SMART QTS1
- BMT68

QUICK TURN SMART
QTS 100M / 200M
QT COMPACT 100M -
200M - 300M



Cod.	ER	H Max	Nm Rpm	LIST PRICE €	SPECIAL PRICE €
99.MZ.A03	32	70	60 6000	1.972	1.749
99.MZ.A06	32	70	60 6000	2.387	2.149

Radial



Cod.	ER	H	Nm Rpm	LIST PRICE €	SPECIAL PRICE €
99.MZ.A75	40	160	100 4000	3.424	3.200
99.MZ.A81	40	160	100 4000	3.943	3.600



Cod.	ER	H	Nm Rpm	LIST PRICE €	SPECIAL PRICE €
99.MZ.A65	32	120	80 6000	2.698	1.649
99.MZ.A66	32	120	80 6000	2.906	1.949



Cod.	ER	H	Nm Rpm	LIST PRICE €	SPECIAL PRICE €
99.MZ.A09	32	80	60 6000	2.698	2.299
99.MZ.A10	32	80	60 6000	2.906	2.599

Direction of rotation opposite to machine spindle

Direction of rotation opposite to machine spindle

DRIVEN TOOLS HOLDERS



DIN
5480



VDI - DIN69880

* In case of order specify always left or right orientation you need

80 BAR

d1	Code	ER	H	Nm	Rpm	LIST PRICE €	SPECIAL PRICE €
30	99.ST.8003	25	66	32	6000	917	779
	99.ST.8011	25	66	32	6000	1.185	979
40	99.ST.8005	32	95	63	6000	1.147	999
	99.ST.8013	32	95	63	6000	1.499	1.229
Direction of rotation same as machine spindle							
30	99.ST.8030	25	55	32	6000	1.926	1.599
	99.ST.8038	25	55	32	6000	2.216	1.829
40	99.ST.8033	32	100	63	6000	2.436	1.999
	99.ST.8041	32	100	63	6000	2.798	2.299
Direction of rotation opposite to machine spindle							

DIN
5482



VDI - DIN69880

* In case of order specify always left or right orientation you need

80 BAR

d1	Code	ER	H	Nm	Rpm	LIST PRICE €	SPECIAL PRICE €
30	99.ST.8201	25	94	32	6000	865	779
	99.ST.8207	25	94	32	6000	1.161	979
40	99.ST.8203	32	115	63	5000	1.041	899
	99.ST.8208	32	115	63	5000	1.347	1.129
Direction of rotation same as machine spindle							
30	99.ST.8217	25	55	32	6000	1.735	1.449
	99.ST.8223	25	55	32	6000	2.025	1.699
40	99.ST.8220	32	100	63	5000	2.078	1.699
	99.ST.8226	32	100	63	5000	2.430	1.999
Direction of rotation opposite to machine spindle							



VDI - DIN69880

* In case of order specify always left or right orientation you need

80 BAR



d1	Code	ER	H	Nm	Rpm	LIST PRICE €	SPECIAL PRICE €
30	99.BF.0003	25	94	32	6000	895	779
	99.BF.0010	25	94	32	6000	1.193	979
40	99.BF.0005	32	117	63	5000	1.079	929
	99.BF.0011	32	115	63	5000	1.391	1.179
Direction of rotation same as machine spindle							
30	99.BF.0021	25	55	32	6000	1.781	1.499
	99.BF.0027	25	55	32	6000	2.086	1.749
40	99.BF.0024	32	100	63	5000	2.140	1.749
	99.BF.0030	32	100	63	5000	2.506	2.049
Direction of rotation opposite to machine spindle							

DIN
1809



VDI - DIN69880

* In case of order specify always left or right orientation you need

80 BAR

d1	Code	ER	H	Nm	Rpm	LIST PRICE €	SPECIAL PRICE €
30	99.DP.0903	25	94	32	6000	865	779
	99.DP.0910	25	94	32	6000	1.161	979
40	99.DP.0905	32	115	63	5000	1.041	879
	99.DP.0911	32	115	63	5000	1.347	1.129
Direction of rotation same as machine spindle							
30	99.DP.0919	25	55	32	6000	1.735	1.449
	99.DP.0925	25	55	32	6000	2.025	1.699
40	99.DP.0922	32	100	63	5000	2.078	1.699
	99.DP.0928	32	100	63	5000	2.430	1.999
Direction of rotation opposite to machine spindle							



BMT 55

NICKEL PLATING SOLID BODY

80 BAR



d1	Code	Biglia Code	ER	H	Nm	Rpm	LIST PRICE €	SPECIAL PRICE €
55	99.BG.A01	10.57.88.00	25	70	47	6000	887	699
	99.BG.A02	T.134-00061	32	70	47	6000	887	699
	99.BG.A03	T.134-00071	32	70	47	6000	1.227	949
Direction of rotation same as machine spindle								

d1	Code	Biglia Code	ER	H	Nm	Rpm	LIST PRICE €	SPECIAL PRICE €
55	99.BG.A05	10.57.87.00	25	70	47	6000	1.661	1.249
	99.BG.A06	T.134-00062	32	70	47	6000	1.661	1.249
	99.BG.A07	T.134-00072	32	70	47	6000	2.179	1.649
	99.BG.A08	T.134-00076	25	100	47	6000	1.868	1.399
	99.BG.A09	T.134-00077	32	100	47	6000	1.868	1.399
	99.BG.A10	T.134-00088	32	100	47	6000	2.179	1.649
Direction of rotation same as machine spindle								

d1	Code	Biglia Code	ER	H	Nm	Rpm	LIST PRICE €	SPECIAL PRICE €
55	99.BG.A15	T.134-00025	16	60	16	6000	3.830	2.849
	99.BG.A16	T.134-00057	20	60	16	6000	3.830	2.849
Direction of rotation same as machine spindle								



NLX 1500 - 2000 - 2500 - 3000

12 Positions

80 BAR

NZX 12 Positions



Code	ER	H Max	Nm	Rpm	LIST PRICE €	SPECIAL PRICE €
99.MS.A59	32	89,9	60	10.000	1.249	999
99.MS.A60	32	89,9	60	10.000	1.847	1.429
99.MS.A62	40	92	60	10.000	1.249	999
99.MS.A63	40	92	60	10.000	1.847	1.429
99.MS.A72	32	90	60	10.000	2.674	2.099
99.MS.A73	32	90	60	10.000	2.993	2.349
99.MS.A76	40	90	60	10.000	2.674	2.099
99.MS.A77	40	90	60	10.000	2.993	2.349

Both direction of rotation to machine spindle available*

NZ 1500 - 2000 - 3100 - 3150 - 3200

16 Positions

80 BAR



Code	ER	H Max	Nm	Rpm	LIST PRICE €	SPECIAL PRICE €
99.MS.A101	25	84,3	50	12.000	1.249	1.049
99.MS.A102	25	84,3	50	12.000	1.847	1.479
99.MS.A103	32	89,2	50	12.000	1.249	1.049
99.MS.A104	32	89,2	50	12.000	1.847	1.479
Direction of rotation same as machine spindle						
99.MS.A106	25	85	50	12.000	2.674	2.099
99.MS.A107	25	85	50	12.000	2.993	2.349
99.MS.A108	32	85	50	12.000	2.674	2.099
99.MS.A109	32	85	50	12.000	2.993	2.349

Direction of rotation opposite to machine spindle

DRIVEN TOOLS HOLDERS



VDI 40



COMPATIBLE WITH



Code	ER	H	h1	Nm	Rpm	LIST PRICE €	SPECIAL PRICE €
99.HA.590082	32	75	117,5	63	6000	945	749
99.HA.590082B	32	75	117,5	63	6000	1.179	899
99.HA.590083	32	75	104,8	63	6000	945	749
99.HA.590083B	32	75	104,8	63	6000	1.179	899
99.HA.596352	32	75	130,25	63	6000	945	749
99.HA.596352B	32	75	130,25	63	6000	1.179	899

Direction of rotation same as machine spindle



* Interchangeable couplings for any type of Haas turret

Code	ER	H	h1	Nm	Rpm	LIST PRICE €	SPECIAL PRICE €
99.HA.590084	32	75	117,5	63	6000	1.773	1.349
99.HA.590084B	32	75	117,5	63	6000	2.240	1.699
99.HA.590085	32	75	104,8	63	6000	1.773	1.349
99.HA.590085B	32	75	104,8	63	6000	2.240	1.699
99.HA.596353	32	75	130,25	63	6000	1.773	1.349
99.HA.596353B	32	75	130,25	63	6000	2.240	1.699

Direction of rotation same as machine spindle



Ø45: WT100-TW1
Ø54: WT100-TW1



d1	Code	ER	H Max	Nm	Rpm	LIST PRICE €	SPECIAL PRICE €
45	99.MY.A02	25	57,6	35	6000	853	749
	99.MY.A03	25	57,6	35	6000	1.022	899
54	99.MY.A09	32	79,4	60	6000	993	849
	99.MY.A10	32	79,4	60	6000	1.140	949
45	99.MY.A05	25	65	35	6000	1.506	1.249
	99.MY.A06	25	65	35	6000	2.456	1.649
54	99.MY.A11	32	75	60	6000	2.284	1.899
	99.MY.A12	32	75	60	6000	2.207	1.849

Direction of rotation opposite to machine spindle



BMT44 WT100-TW1
BMT55 SUPER NTJ-NTJX/NTM 3/TMC 18/
TW10/SC150-250/WT150-250/WTW 150/WTS 150/WT100



d1	Code	ER	H Max	Nm	Rpm	LIST PRICE €	SPECIAL PRICE €
45	99.NK.A40	25	57,2	40	6000	946	799
	99.NK.A43	25	57,2	40	6000	1.081	899
55	99.NK.A03	32	72,2	63	6000	993	849
	99.NK.A04	32	72,2	63	6000	1.530	1.299
45	99.NK.A50	25	60	40	6000	1.676	1.399
	99.NK.A53	25	60	40	6000	2.008	1.699
55	99.NK.A13	32	55	63	6000	1.868	1.549
	99.NK.A14	32	55	63	6000	2.519	2.099

Direction of rotation same as machine spindle



BMT60: SPACE TURN LB 200EX/LB 2500EX/LB3000EX/GENOS SERIES L300-MW/
MULTUS U3000/U40007/LU3000EX M/MY



d1	Code	ER	H Max	Nm	Rpm	LIST PRICE €	SPECIAL PRICE €
60	99.OKA80	32	79	60	6000	1.687	1.299
	99.OKA81	32	79	60	6000	2.141	1.599
60	99.OKA82	32	70	60	6000	3.048	2.299
	99.OKA83	32	70	60	6000	3.631	2.749

Direction of rotation opposite to machine spindle



VDI40 OKUMA CAPTAIN L370 M - ES L10 M - GENOS L300, L3000-E M/MY (VDI40)
LB 300 MW - LB/LU 300 MY - LB/LU 300, 3000 M (VDI40)



Axial

Code	ER	H	Nm	Rpm	LIST PRICE €	SPECIAL PRICE €
99.OK.A18	32	98,6	70	6000	1.947	1.499
99.OK.A23	32	98,6	70	6000	2.465	1.899

Radial

Code	ER	H	Nm	Rpm	LIST PRICE €	SPECIAL PRICE €
99.OK.A19	32	70	60	6000	3.373	2.549
99.OK.A25	32	70	60	6000	4.151	3.149



BMT60 EX 380 / 310 / 508 / 510 / 708 / 710 / 910 - EX 2000 M/Y - TC 350 MC - TT 350 MC - NEX 108/110/908/910 - LA 200/250 M/Y - LA 250 YS (15 stations) - FX 800 - MX 800 - VTL 450 M - LX 2500 M/Y



Code	ER	H	Nm	Rpm	LIST PRICE €	SPECIAL PRICE €
99.TK.A12	32	93	50	6000	1.499	1.149
99.TK.A13	32	93	50	6000	2.213	1.699

Radial

Code	ER	H	Nm	Rpm	LIST PRICE €	SPECIAL PRICE €
99.TK.A02	32	90	50	6000	3.139	2.399
99.TK.A05	32	90	50	6000	3.333	2.549



BMT65: M06D/M06SD/M06SY/M08SD/M08SY



Axial

Cod.	ER	H Max	Nm	Rpm	PREZZO LISTINO €	PREZZO OFFERTA €
99.TS.A01	25	60	40	8000	1.558	1.099
99.TS.A03	32	60	40	8000	2.141	1.699
99.TS.A02	25	60	40	8000	2.141	1.699
99.TS.A04	32	60	40	8000	2.141	1.699

Radial

Code	ER	H	Nm	Rpm	PREZZO LISTINO €	PREZZO OFFERTA €
99.TS.A08	25	65	40	8000	2.529	1.749
99.TS.A10	32	65	40	8000	3.112	2.199
99.TS.A09	25	65	40	8000	3.112	2.199
99.TS.A11	32	65	40	8000	3.112	2.199



3-PUNT BINNENMICROMETER

- Meet DIN863-4
- 6-12mm: nauwkeurigheid 0.001mm
- 12-200mm: nauwkeurigheid 0.005mm
- Ratel stop

IP67
WATERPROOF

INSPECTION
CERTIFICATE



TYPE A



TYPE B



TYPE C

Artikel nummer	Range	Type	Nauwkeurigheid	Instel ring (inclusief)	Verlenghuls	L	A	B	C	Actieprijs
3227-8*	6-8mm	A	4µm	Ø6mm (inclusief)	100mm	54.5	1.5	2.5	-	€ 236,00
3227-10*	8-10mm	A	4µm	Ø8mm (inclusief)	100mm	54.5	1.5	2.5	-	€ 236,00
3227-12*	10-12mm	A	4µm	Ø10mm (inclusief)	100mm	54.5	1.5	2.5	-	€ 236,00
3227-16*	12-16mm	B	4µm	Ø16mm (inclusief)	150mm	80	0.5	6	4.5	€ 188,00
3227-20*	16-20mm	B	4µm	Ø16mm (inclusief)	150mm	80	0.5	6	4.5	€ 188,00
3227-25*	20-25mm	B	4µm	Ø25mm (inclusief)	150mm	90	0.5	8	6	€ 247,00
3227-30*	25-30mm	B	4µm	Ø25mm (inclusief)	150mm	90	0.5	8	6	€ 247,00
3227-40*	30-40mm	B	4µm	Ø40mm (inclusief)	150mm	97	0.5	14	12	€ 281,00
3227-50*	40-50mm	B	5µm	Ø40mm (inclusief)	150mm	97	0.5	14	12	€ 306,00
3227-63*	50-63mm	C	5µm	Ø62mm (inclusief)	150mm	114	0.5	17.5	14.5	€ 339,00
3227-75*	62-75mm	C	5µm	Ø62mm (inclusief)	150mm	114	0.5	17.5	14.5	€ 351,00
3227-88*	75-88mm	C	5µm	Ø87mm (inclusief)	150mm	114	0.5	17.5	14.5	€ 369,00
3227-100*	87-100mm	C	5µm	Ø87mm (inclusief)	150mm	114	0.5	17.5	14.5	€ 387,00
3227-125*	100-125mm	C	5µm	Optie	150mm	140	0.9	29	25	€ 485,00
3227-150*	125-150mm	C	5µm	Optie	150mm	140	0.9	29	25	€ 549,00
3227-175*	150-175mm	C	7µm	Optie	150mm	140	0.9	29	25	€ 608,00
3227-200*	175-200mm	C	7µm	Optie	150mm	140	0.9	29	25	€ 702,00



INSELRING
6-100mm: inclusief
100-200mm: optioneel

VERLENGHULS
inclusief



Artikel nummer	Range	Inbegrepen Micrometers	Instel ring (inclusief)	Verlenghuls (inclusief)	Actieprijs
3227-123*	6-12mm	6-8mm, 8-10mm, 10-12mm	Ø6mm, Ø8mm, Ø10mm	100mm	€ 559,00
3227-202*	12-20mm	12-16mm, 16-20mm	Ø16mm	150mm	€ 327,00
3227-504*	20-50mm	20-25mm, 25-30mm, 30-40mm, 40-50mm	Ø25mm, Ø40mm	150mm	€ 773,00
3227-1004*	50-100mm	50-63mm, 62-75mm, 75-88mm, 87-100mm	Ø62mm, Ø87mm	150mm	€ 1.104,00

*Geleverd met inspectiecertificaat van de fabrikant

IP67 DIGITALE SCHUIFMAAT

- Nauwkeurigheid: $\pm 0.03\text{mm}$
- IP67 stof/waterdicht
- Aflezing: 0.01mm
- Automatisch uitschakelen



1115-150

IP67
WATERPROOF

INSPECTION
CERTIFICATE

Artikel nummer	Range	Nauwkeurigheid	L	A	B	C	D	Actieprijs
1115-150*	0-150	± 0.03	235	20	15	16	40	€ 67,00
1115-200*	0-200	± 0.03	287	24	19	16	50	€ 107,00
1115-300*	0-300	± 0.03	388	26	21	16	60	€ 132,00

PRIJS V.A.

€ 67,-

*Geleverd met inspectiecertificaat van de fabrikar

DIGITALE SCHUIFMAAT

- Nauwkeurigheid: $\pm 0.03\text{mm}$
- IP67 stof/waterdicht
- Aflezing: 0.01mm
- Automatisch uitschakelen



1136-501

IP67
WATERPROOF

INSPECTION
CERTIFICATE

Artikel nummer	Range	Nauwkeurigheid	L	A	B	C	D	Actieprijs
1136-301*	0-300	± 0.05	42	18	45	24	100	€ 253,00
1136-451*	0-450	± 0.05	625	18	45	24	100	€ 320,00
1136-501*	0-500	± 0.05	675	18	45	24	100	€ 242,00
1136-502*	0-500	± 0.06	675	18	45	24	150	€ 366,00
1136-503*	0-500	± 0.06	675	24	60	31	200	€ 468,00
1136-601*	0-600	± 0.05	770	18	45	24	100	€ 317,00
1136-1002*	0-1000	± 0.08	1220	24	60	31	150	€ 708,00
1136-1502*	0-1500	± 0.11	1780	24	60	42	150	€ 1.505,00
1136-2002*	0-2000	± 0.14	2290	24	60	42	150	€ 2.217,00

PRIJS V.A.

€ 253,-

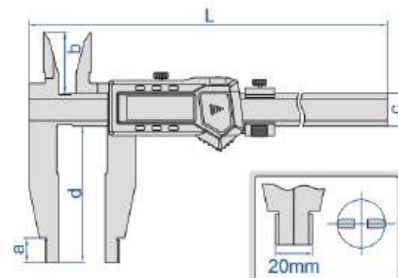

PARALLEL SETS

- Parallelisme tussen boven en onder: $5\mu\text{m}$
- Hoogteverschil van een bij elkaar passend paar: $5\mu\text{m}$
- Gemaakt van gelegeerd gereedschapsstaal
- Gehard tot HRC55-60



PRIJS V.A.

€ 253,-

Artikel nummer	Aantal paar	Lengte (L)	Hoogte (H) x Dikte (W)	Actieprijs
6511-20	20	100 mm	5x2*, 10x2, 15x2, 20x2, 6x3*, 11x3, 16x3, 21x3, 7x4*, 12x4, 17x4, 22x4, 8x5*, 13x5, 18x5, 23x5, 9x6*, 14x6, 19x6, 24x6mm	€ 253,00
6511-24	24	125 mm	11x8, 16x8, 21x8, 26x8, 31x8, 36x8, 13x10, 18x10, 23x10, 28x10, 33x10, 38x10, 15x12, 20x12, 25x12, 30x12, 35x12, 40x12, 17x14, 22x14, 27x14, 32x14, 37x14, 42x14mm	€ 359,00
6511-241	24	125 mm	11x8, 16x8, 21x8, 26x8, 31x8, 36x8, 13x10, 18x10, 23x10, 28x10, 33x10, 38x10, 15x12, 20x12, 25x12, 30x12, 35x12, 40x12, 17x14, 22x14, 27x14, 32x14, 37x14, 42x14mm	€ 412,00

*Paralleliteit tussen boven- en onderkant en hoogteverschil van een bij elkaar passend paar van 5x2mm, 6x3mm, 7x4mm, 8x5mm en 9x6mm in 6511-20 is $7\mu\text{m}$

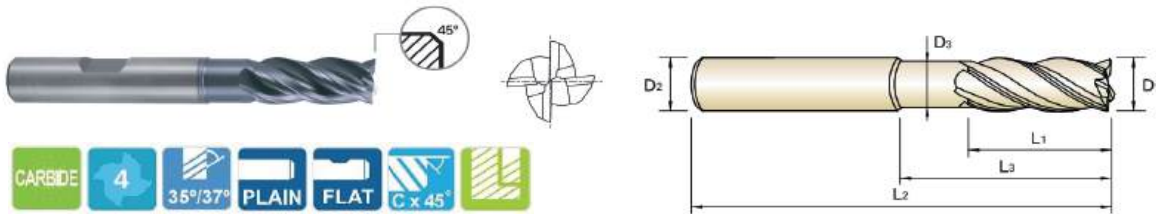

- Speciale geometrie met meervoudige helix elimineren trillingen
- Uitstekende prestaties voor RVS soorten, zacht staal, gietijzer en materialen met een lage/gemiddelde hardheid onder HRc40

Art. nr	D1	D2	D3	L1	L3	L2	Actieprijs
GMF61901	3	6	2.7	7	17	57	€ 18,50
GMF61904	4	6	3.7	11	16	57	€ 18,50
GMF61906	5	6	4.7	13	18	57	€ 18,50
GMF61909	6	6	5.5	13	21	57	€ 18,50
GMF61912	8	8	7.5	19	27	63	€ 26,00
GMF61915	10	10	9.2	22	32	72	€ 42,00
GMF61918	12	12	11	26	38	83	€ 57,50
GMF61921	16	16	15	32	44	92	€ 98,00
GMF61924	20	20	19	38	54	104	€ 173,50



SCAN DE QR CODE VOOR DE SNIJGEGEVENS

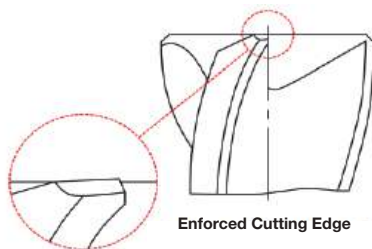

GMF61SET5
6 + 8 + 10 + 12 + 16mm

ACTIE
€ 230,-

◎ : Excellent ○ : Good

ISO	P										M				K						
	Non-alloy steel					Low alloy steel					High alloyed steel, and tool steel				Stainless steel		Grey cast iron		Nodular cast iron		Malleable cast iron
VDI 3323	1	2	3	4	5	6	7	8	9	10	11	12	13	14	15	16	17	18	19	20	
HRc	13	25	28	32	38	10	29	32	38	15	35	15	23	10	10	26	3	25	21		
HB	125	190	250	270	300	180	275	300	350	200	325	200	240	180	180	260	160	250	130	230	
Recommended	◎	◎	◎	◎	◎	◎	◎	◎	◎	◎	◎	◎	◎	◎	◎	◎	◎	◎	◎	◎	◎

ISO	N										S						H					
	Aluminum-wrought alloy		Aluminum-cast, alloyed			Copper and Copper Alloys (Bronze / Brass)		Non Metallic Materials			Heat Resistant Super Alloys						Titanium Alloys		Hardened steel	Chilled Cast Iron	Hardened Cast Iron	
VDI 3323	21	22	23	24	25	26	27	28	29	30	31	32	33	34	35	36	37	38	39	40	41	
HRc											15	30	25	38	34			55	60	42	55	
HB	60	100	75	90	130	110	90	100			200	280	250	350	320	400 Rm	1050 Rm	550	630	400	550	
Recommended											○	○	○	○	○	○	○					

MEEDRAAIEND CENTER PRO RÖHM

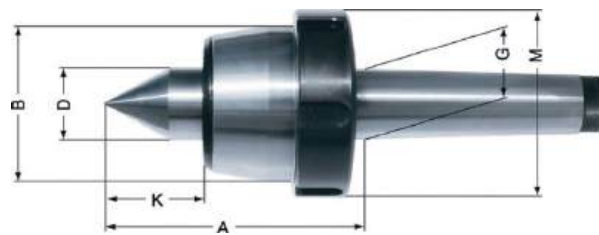

Art. nr	Opname	werkstuk gewicht max. (KG)	Rondloopnauwkeurigheid	Toerental max.	A (mm)	B (mm)	D (mm)	G (mm)	K (mm)	Actieprijs
42776	MK3	500	0,005	5000	79,5	58,5	25	23,825	31	€ 319,00
42175	MK4	800	0,005	3800	102,5	68,5	32	31,267	41	€ 365,00
42843	MK5	2000	0,005	3000	129	88,5	40	44,399	50,5	€ 525,00

MEEDRAAIEND CENTER SLIM MET VERLENGDE LOOPPUNT RÖHM

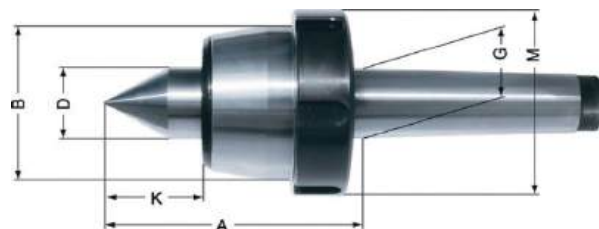

Art. nr	Opname	werkstuk gewicht max. (KG)	Rondloopnauwkeurigheid	Toerental max.	A (mm)	B (mm)	D (mm)	G (mm)	K (mm)	Actieprijs
362081	MK3	340	0,008	7000	74	34	15	23,825	32	€ 265,00
362082	MK4	700	0,008	6300	88,5	42	20	31,267	37,5	€ 349,00
362083	MK5	1400	0,01	4300	119	58	30	44,399	51,5	€ 505,00

ANTI VIBRATIE HOUDERS

- Trillingsdemping
- Diepe en nauwkeurige bewerking
- Hoge toleranties
- Verhoging van standtijd wisselplaat
- Boor baren maken bewerkingen tot 14xD mogelijk (draaien)



VRAAG NAAR DE MOGELIJKHEDEN



WEMAG-EDITION



WEMAG Bit-Box, 32-teilig

Beschreibung:

- PH
- PZ
- Schlitz
- Torx
- 6-kant
- 1/4" Adapter
- Clip-Halter



Lieferumfang: PH1, 2 (2x), 3; PZ1, 2 (2x), 3; S3, 4, 5, 6; HEX3, 4, 5, 6; T10, 15, 20 (2x), 25, 27, 30, 40; TH10, 15, 20, 25, 27, 30, 40, 1/4" Adapter, Clip-Halter

Artikelnr.		Preis
4006913.0032	1 Stück	12,90
	ab 10 Stück	à 10,90 (5423)

WEMAG Winkelschraubendreher-Satz lang, 9-teilig

Beschreibung:

- 1,5 – 10 mm
- 6-kant
- Beschichtung: Glanzverchromt
- Mit Kugelkopf



Lieferumfang: 1,5; 2; 2,5; 3; 4; 5; 6; 8; 10 mm 6-kant mit Kugelkopf, Halter

Artikelnr.		Preis
4007070.9000	1 Stück	14,90
	ab 6 Stück	à 12,90 (5423)

WEMAG Bandmaß mit Gürtelclip, 3 m + 5 m

Beschreibung:

- Kunststoffgehäuse
- Gürtelklammer
- Bandfeststeller für einfache Handhabung
- Bänder entsprechen der EG-Klasse II



Artikelnr.		Preis
3001031.0030	1 Stück – 3 m	3,99
	ab 12 Stück	à 3,79
3001031.0050	1 Stück – 5 m	4,99
	ab 12 Stück	à 4,69 (5423)

WEMAG Ring-Ratschenschlüssel-Satz, 12-teilig



Lieferumfang: Ring-Ratschenschlüssel 8 – 19 mm, in praktischer Rolltasche

Artikelnr.		Preis
4006325.0200	1 Stück	89,90
	ab 5 Stück	à 85,90 (5423)

WEMAG Drehmomentschlüssel, Feinzahn, 1/2", 40 – 200 Nm

Beschreibung:

- Mit Feinzahn-Umschaltknarre
- Klicksignal bei Einstellen des gewünschten Drehmomentes
- Durch Drehen des Griffes wird der gewünschte Drehmoment eingestellt
- Kein Zurückdrehen auf den kleinsten Skalenwert erforderlich

Technische Daten:

Min. Drehmoment:	40 Nm
Max. Drehmoment:	200 Nm
Auslösegenauigkeit:	+/-3 %
Skalenteilungswert:	1 Nm
Gesamtlänge:	530 mm
Norm:	EN/ISO 6789



Lieferumfang: Drehmomentschlüssel, inkl. Seriennummer, Kalibrierschein, in Kunststoffhülse



Artikelnr.	Beschreibung	Preis
4011837.0100	40 – 200 Nm	129,90
	ab 3 Stück	à 119,90 (5413)

WEMAG-EDITION



WEMAG Trennscheibe gerade

Beschreibung:

- Für Stahl/Edelstahl
- Universal einsetzbar
- Optimal für schnelles und gratarmes Trennen

Technische Daten:

Materialeignung: Stahl/Edelstahl



Artikelnr.	Maße		Preis
4502126.0125	125 x 1 x 22,23 mm	ab 25 Stück	à 0,78
		ab 100 Stück	à 0,69
		ab 200 Stück	à 0,59
4502988.0125	125 x 2,5 x 22,23 mm	ab 25 Stück	à 1,09
		ab 100 Stück	à 0,89
		ab 200 Stück	à 0,79
4502126.0230	230 x 1,9 x 22,23 mm	ab 25 Stück	à 2,29
		ab 100 Stück	à 1,99
		ab 200 Stück	à 1,79

(4763)

WEMAG HIGH PERFORMANCE HM-Trennscheibe WOOD CUT AKKU

Beschreibung:

- Hervorragend geeignet für den Akku-Winkelschleifer
- Hartmetall bestückte Segmente
- Perfekt für den Innenausbau
- Superdünner Schnitt

Technische Daten:

Maße: 125 x 22,23 x 1,2 mm
 Segmente: 12
 Materialeignung: Für alle Holzarbeiten, Laminat, Vinyl, Kunststoffe etc.



Artikelnr.	Beschreibung	Segmente	Preis
4502746.0125	125 x 22,23 x 1,2 mm	12	26,59
	ab 10 Stück		à 25,19

(4773)

WEMAG Schrupscheibe gewölbt

Beschreibung:

- Angenehmes Schleifverhalten
- Hochwertiges Korund

Technische Daten:

Maße: 125 x 7 x 22,23 mm
 Materialeignung: Stahl/Edelstahl

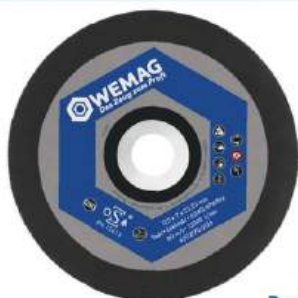

VE 10 Stück

Artikelnr.	Beschreibung	Preis
4502170.0125	ab 10 Stück	à 1,75
	ab 100 Stück	à 1,59
	ab 200 Stück	à 1,49

(4763)

WEMAG HIGH PERFORMANCE Schrupscheibe Keramik-Korn

Beschreibung:

- Höchste Zerspanungsleistung
- Hochwertiges keramisches Schleifkorn

Technische Daten:

Maße: 125 x 7 x 22,23 mm
 Materialeignung: Stahl/Edelstahl



VE 10 Stück

Artikelnr.	Beschreibung	Preis
4502736.0125	ab 10 Stück	à 4,39
	ab 100 Stück	à 3,99
	ab 200 Stück	à 3,59

(4763)

WEMAG Fächerschleifscheibe Zirkonkorund - gerade

Beschreibung:

- Angenehmes Schleifverhalten
- Zirkonkorund

Technische Daten:

Maße: 115 x 22,23 mm
 Ausführung: gerade Korn 40
 Materialeignung: Stahl/Edelstahl



VE 10 Stück

Artikelnr.	Beschreibung	Preis
4502737.0040	ab 10 Stück	à 1,89
	ab 100 Stück	à 1,79
	ab 200 Stück	à 1,59

(4763)

Abbildung ähnlich

WEMAG Fächerschleifscheibe Zirkonkorund - schräg

Beschreibung:

- Sehr hohe Zerspanungsleistung
- Zirkonkorund

Technische Daten:

Maße: 125 x 22,23 mm
 Ausführung: schräg Korn 40 oder schräg Korn 60
 Materialeignung: Stahl/Edelstahl



VE 10 Stück

Artikelnr.	Beschreibung	Preis	Artikelnr.	Beschreibung	Preis
4502738.0040	Korn 40		4502738.0060	Korn 60	
	ab 10 Stück	à 1,89		ab 10 Stück	à 1,89
	ab 50 Stück	à 1,79		ab 50 Stück	à 1,79
	ab 100 Stück	à 1,59		ab 100 Stück	à 1,59

(4763)

WEMAG-EDITION



WEMAG HIGH PERFORMANCE Blue Nature Max - nachhaltiger Montagehandschuh

Beschreibung:

- Norm: EN 388, EN 407
- Aus recyceltem Polyester
- Recyceltes Polyester reduziert CO₂-Emissionen
- Lange Lebensdauer
- Sehr gute Passform
- Optimaler Grip
- Für trockene und leicht ölige Oberflächen
- **Material:** Liner aus recyceltem Polyester, Nylon, Spandex
- **Beschichtung:** Nitril-Mikroschaum auf der Handinnenfläche
- **Größe:** 6 - 12



Artikelnr.		Preis
8010798. + Größe	1 Paar	2,49
	ab 12 Paar	à 2,29
	120 Paar	à 1,99
		(8543)

uvex Schutzbrille pheos WEMAG Edition, 9192.415

Beschreibung:

- Norm: EN 166, EN 170
- rahmenlos für ein extragroßes Sichtfeld
- ergonomisch geformte Bügel mit weichen Bügelenden sorgen für komfortablen, sicheren Halt ohne Druckstellen
- anatomisch geformte Nasenauflege
- metallfrei
- **Farbe:** anthrazit, blau/W 166 FT CE
- Scheibe: PC farblos, UV 400 / 2C-1,2 W1 FKN CE
- Beschichtung: uvex supravision ETC.



Artikelnr.		Preis
8003367.0050	1 Stück	8,99
	ab 10 Stück	à 8,19
	ab 50 Stück	à 7,39
	ab 160 Stück	à 6,69
		(8533)

WEMAG Schutzbrille „sporty“, EN 166

Beschreibung:

- DIN EN 166, CE
- Farblos/Blau
- Hoher Tragekomfort
- Gummierte Bügel



Artikelnr.		Preis
8005204.0200	1 Stück	1,99
	ab 12 Stück	1,59
		(8533)

WEMAG Kapselgehörschutz SNR: 32 dB (A)

Beschreibung:

- Effiziente Geräuschreduzierung
- Bequemes Design
- Universell für Erwachsene und Kinder
- Sicherheit und Zertifizierung CE EN 352.1 geprüft
- Klappbar
- Pegelbereich:
- Hoch: 40 dB (A)
- Mittel: 30 dB (A)
- Tief: 23 dB (A)
- **Farbe:** Schwarz/Rot



Artikelnr.		Preis
8001108.0032	1 Stück	13,99
	ab 10 Stück	à 10,99
		(8533)

WEMAG Stufenbohrer HSS

Beschreibung:

- Stufenlänge 4-5 mm
- 2 Schneiden
- 3 Flächen am Schaft
- mit Anbohrer
- Stufen in 1 Nute zusätzlich mit Durchmesser gelasert



Stahl			INOX		Guss		Sonder-Legierung		NE-Metalle				Gehärteter Stahl				
< 700 N/mm ²	< 1.000 N/mm ²	< 1.400 N/mm ²	< 700 N/mm ²	> 700 N/mm ²	GG/GTS	GGG	Inconel, Hastelloy, Nimonic	Titan	Alu lang	Alu kurz	Alu > 8% Si	Kupfer, Messing, Bronze	Kunststoff, Thermoplaste	Graphit/GFK/CFK	< 55 HRC	< 60 HRC	> 60 HRC
200-400			100-200		vc = m/min.												
									500-1.000	500-1.000	500-1.000	1.000-1.500					
Artikelnr.	Bohrbereich Ø								Schaft-Ø	Schaftlänge	Gesamtlänge	Preis					
1005541.0412	4/5/6/7/8/9/10/11/12								6	22	80	21,70					
1005541.0620	6/8/10/12/14/16/18/20								9	22	70	25,45					
1005541.0630	6/8/10/12/14/16/18/20/22/24/26/28/30								10	24	100	42,95					
1005541.9000	Stufenbohrer-Set, 3-teilig (1005541.0412, 1005541.0620, 1005541.0630), 4-30 mm, Ø 2 mm Stufung, in Kunststoff-Kassette								107,35								
									(1017)								

YG-1 TAP MET SPAANBREKER



PRODUCTINFORMATIE



Speciaal geslepen spaanhoek biedt uitstekende prestaties i.c.m. spaanbreker om de spaanafvoer te optimaliseren

SPAANBREKER

- YG-1 speciale draad structuur
- HSS-E materiaal
- 15° spiraalhoek
- TiN coating



DE PROBLEEMOPLOSSER

YG-1 ROLTAPPEN



- Sneller draad creëren
- Voor blinde als doorlopende gaten
- Sterkere schroefdraad
- Spaanvrij tappen
- Langere levensduur

PRODUCTINFORMATIE



SPAANVRIJ DRAAD VORMEN

UITWISSELBARE 'MINI TOOLS'



PRODUCTINFORMATIE



Patents and Certifications
PATENTED

40 years experiences
30 patents approval
Innovation and global integration
The glory of Taiwan

A collection of various Y.T. drill bits and a circular saw blade are displayed against a dark, starry background. The drill bits are arranged in a line, showing different sizes and designs. The saw blade is on the right, highlighted with a blue circular glow.

SAW BLADE
SLITTING / SLOTTING / CUT-OFF SERIES

A row of various Y.T. saw blades is displayed against a dark background. The blades are arranged in a line, showing different sizes and designs. The blades are primarily black with some yellow accents.

UFO Family
One holder fits different inserts
up to 400 types

A row of various Y.T. UFO Family drill bits is displayed against a dark background. The bits are arranged in a line, showing different sizes and designs. The bits are primarily silver with yellow accents.



VOLG ONS



WHATSAPP
+31-06-17714749



YOUNG CUTTINGTOOLS BV

Meerheide 100b
5521 DX Eersel
Postbus 60
5520 AB Eersel

Tel. +31 (0)497-820213
Fax +31 (0)497-820214
info@youngcuttingtools.nl
www.youngcuttingtools.nl

Prijzen exclusief BTW, prijzen zijn geldig t/m 01-03-2025 onder voorbehoud van prijswijzigingen en drukfouten.